

NORIOTA

INSTALLATION AND INSTRUCTION MANUAL

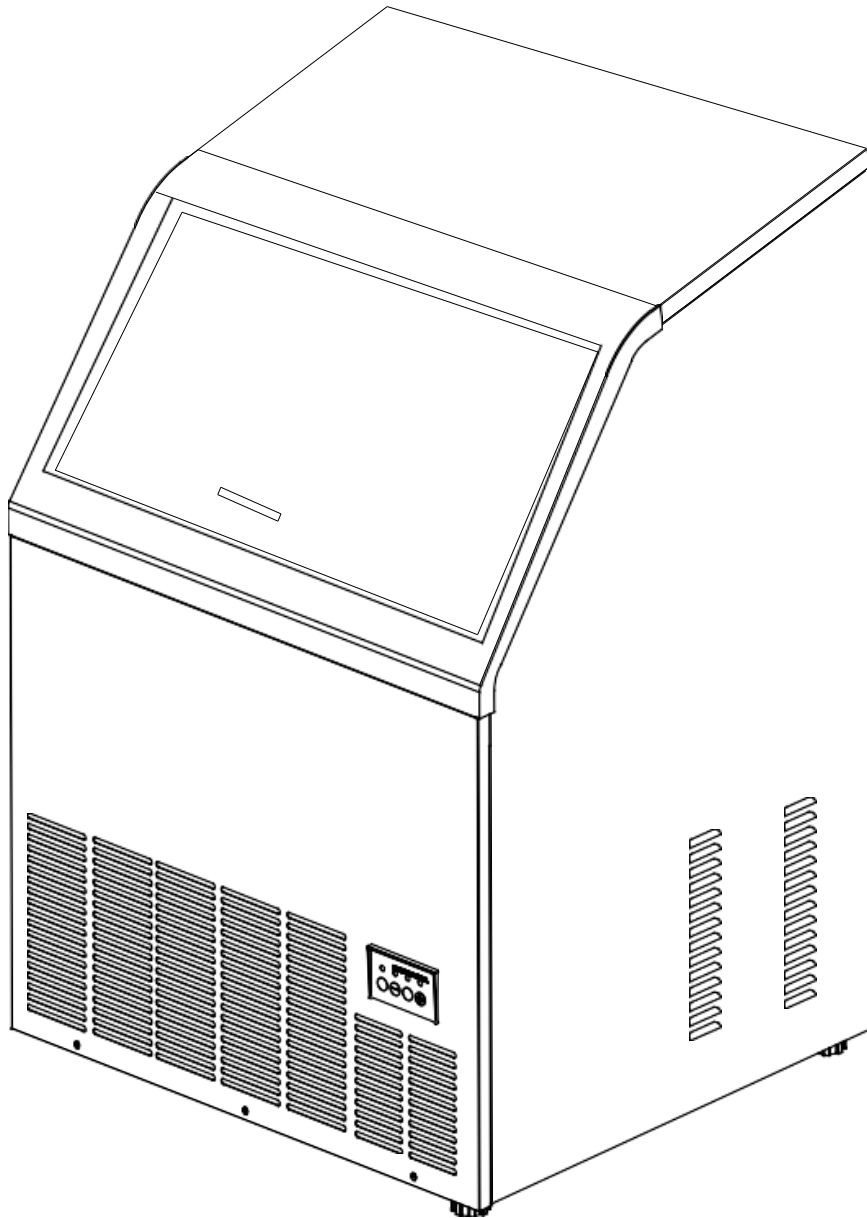

**ICE60, ICE80, ICE100, ICE120 SERIES
NI60, NI80, NI100, NI120 SERIES**

COMMERCIAL UNDERCOUNTER ICE MACHINES

QUICK START AND KEY OPERATING REMINDERS

Before operating this equipment, review the following key points to help ensure proper ice production, sanitation, reliability, and long equipment life.



NOTICE!

This guide highlights important safety and operating reminders only. It does not replace the full Installation and Instruction Manual. Read and follow the full manual before installing, operating, cleaning, or servicing this unit.

Important Safety Reminders

- Commercial foodservice use only. Do not spray, hose down, pressure wash, or steam clean the unit.
- Do not block the front grille or required airflow clearances.
- Do not store items on top of the unit or inside the ice storage bin.
- Ice is a food-contact product. Use only clean ice scoops and sanitary handling practices.
- If the power cord, plug, water line, drain line, controls, or refrigeration tubing become damaged, discontinue use and contact **qualified service personnel**.

Before First Use

- Remove all packaging materials, tape, protective film, and shipping materials.
- Install the unit on a stable, level surface with proper airflow clearance.
- Confirm the drain hose maintains continuous downward slope.
- Flush water supply line before connection and confirm it is leak-free.
- Install the included sediment filter correctly.
- Wipe interior surfaces and the storage bin clean before operation.
- Confirm the ice slideway moves freely and is not blocked.
- Allow unit to remain upright and unplugged for at least 24 hours if tilted, laid on its back or side, or transported non-upright. If kept upright continuously, wait at least 10 minutes before startup.

Startup and Ice Production

1. Turn on the water supply.
2. Plug the unit into a properly grounded outlet matching the rating label.
3. Press **ON/OFF** to begin ice production.
4. First harvest may take up to 60 minutes under normal conditions. Discard the first two batches of ice.

After a power outage or power interruption, the unit returns to standby mode and must be restarted using the **ON/OFF** button. Ice production capacity depends heavily on ambient temperature, water temperature, airflow, and installation conditions.

Ice Handling and Daily Operation

- Keep the door closed whenever possible.
- Store the ice scoop on the scoop holder when not in use. Do not use bare hands to remove ice.
- Remove ice regularly to maintain freshness and proper bin-full operation.
- Keep the front grille and airflow openings clean and unobstructed and clean condenser regularly.
- Clean, descale, and sanitize the unit regularly, especially in hard-water environments.

Normal Operating Characteristics

- Water filling, flowing, splashing, or draining
- Ice cracking or dropping during harvest
- Indicator lights cycling or flashing during operation
- Temporary pauses between freeze and harvest cycles
- Fan and compressor cycling during operation
- Reduced production during high ambient temperature conditions
- Automatic shutdown when the storage bin becomes full and restart after enough ice is removed or melts from the storage bin

Need Help

For product support, manuals, or service assistance:



Website
www.noriota.ca



Phone
1-877-NORIOTA



Email
support@noriota.ca

Please have your model and serial number available when contacting support.

TABLE OF CONTENTS

INTRODUCTION.....	3
Important Information for Owners and Operators.....	3
Intended Use.....	3
Manual Scope and Updates.....	4
Technical Information.....	4
RECEIVING AND INSPECTING THE EQUIPMENT.....	5
Important Handling Notes.....	5
Receiving Inspection.....	5
Concealed Damage Inspection.....	5
Reporting Damage.....	5
Serial Number Information.....	5
SAFETY INFORMATION.....	6
General Safety Instructions.....	7
Electrical Safety.....	7
Flammable Refrigerant Safety.....	8
Water Supply, Drain, and Leak Prevention Safety.....	8
Mechanical, Moving Part, and Surface Safety.....	8
Equipment Handling and Misuse.....	9
Ice Handling and Food Safety.....	9
Cleaning and Sanitation Safety.....	9
Service and Repair Safety.....	10
Unit Disposal.....	10
Refrigerant Disposal.....	10
INSTALLATION.....	11
Installation Responsibility and Code Compliance.....	11
Pre-Installation Checklist.....	11
Compressor Settling Time.....	12
Unpacking and Packaging Removal.....	12
Location and Placement Requirements.....	12
Free-Standing and Built-In Installation.....	13
Clearance and Ventilation Requirements.....	13
Leveling and Adjustable Feet.....	14
Electrical Supply Requirements.....	15
Water Supply Requirements.....	15
Included Sediment Filter and Water Filtration.....	16
Drain Requirements.....	17
Common Causes of Low Ice Production.....	18
Final Installation Checks.....	19
Installation and Warranty Conditions.....	19
OPERATION.....	20
Before First Use.....	20
Understanding Ice Machine Operation.....	20
Control Panel Overview.....	21
Initial Startup Procedure.....	24
Bin Full Operation.....	25
Power Interruption and Restart Behavior.....	26
Ice Removal and Ice Handling.....	26
Normal Sounds and Operating Characteristics.....	26
Shutdown Procedure.....	27
Extended Shutdown and Storage.....	27
Freeze Protection and Cold Weather Storage.....	28
Restarting After Extended Shutdown.....	28
CLEANING AND MAINTENANCE.....	30
Cleaning and Maintenance Safety.....	30
Cleaning, Descaling, and Sanitizing Overview.....	30
Descaling the Water System.....	31
Sanitizing the Ice Machine and Bin.....	32
Condenser Cleaning.....	33
Drain System Inspection and Cleaning.....	34
Exterior Cleaning.....	34
Preventive Maintenance and Service Boundary.....	35
Water Distribution Tube Cleaning.....	35
Recommended Cleaning and Maintenance Schedule.....	37
Maintenance Log.....	38
TROUBLESHOOTING GUIDE.....	39
Before Calling for Service.....	39
When to Stop and Call for Service.....	43
Fault Indicator Codes.....	44
WARRANTY, SERVICE, AND SPARE PARTS.....	45
COMMISSIONING RECORD.....	46

INTRODUCTION

This manual provides installation, operation, cleaning, and maintenance instructions for NORIOTA commercial undercounter ice machines. These units are designed for professional use in commercial kitchens, restaurants, bars, cafés, hotels, convenience stores, break rooms, offices, commissaries, catering operations, institutional facilities, and similar foodservice environments. Proper installation, operation, water quality management, drainage, airflow, cleaning, sanitizing, and maintenance are essential for safe operation, consistent ice production, sanitary ice storage, energy efficiency, and long equipment life.

This manual applies to NORIOTA commercial undercounter ice machine models ICE60U, ICE80U, ICE80UH, ICE100U, ICE100UH, ICE120U, ICE120UH, NI60F, NI80F, NI80H, NI100F, NI100H, NI120F, and NI120H. Always refer to the unit rating label for exact technical information including electrical requirements, refrigerant type, refrigerant charge, model identification, and serial number.

NORIOTA commercial undercounter ice machines use an air-cooled refrigeration system, vertical evaporator, water distribution system, automatic freeze and harvest cycles, and internal ice storage bin to produce and store slab-style full dice or half dice ice cubes. During ice production, water flows over the evaporator, freezes into a slab of connected cubes, releases during the harvest cycle, and falls into the storage bin. Performance depends on ambient temperature, incoming water temperature, water quality, water pressure, airflow, drainage, leveling, cleaning, ice thickness adjustment, maintenance, operator technique, and installation conditions.

Pay particular attention to electrical supply, potable water connection, gravity drainage, condenser airflow, installation clearances, leveling, cleaning and sanitizing procedures, ice handling practices, flammable refrigerant safety, and operator training.

Important Information for Owners and Operators

Read this manual completely before installing or operating the equipment.

- Installation, electrical connection, water supply connection, drain connection, and servicing must comply with applicable local codes and regulations.
- This equipment is intended for commercial foodservice use only. It is not intended for household, residential, or other non-commercial use.
- This equipment is intended for indoor use in controlled commercial locations only.
- Improper installation, use, cleaning, sanitizing, or maintenance may result in injury, electrical shock, fire or explosion hazard, refrigerant exposure, water leakage, unsanitary ice, reduced ice production, poor ice quality, equipment damage, property damage, or unsafe operation.
- Do not operate if the power cord, plug, controls, refrigeration tubing, water lines, drain line, door, ice slideway, condenser, fan, or electrical components appear damaged or are not functioning properly.
- Ice production depends on ambient temperature, incoming water temperature, water quality, water pressure, airflow, drainage, cleaning condition, and operating environment. Actual ice production may vary depending on installation and operating conditions.
- Keep this manual readily accessible for operators and service personnel.

Following these guidelines helps ensure safe operation, sanitary ice production, consistent performance, and long equipment life. Failure to follow these instructions may result in unsafe conditions, equipment damage, water leakage, reduced ice production, poor ice quality, unsanitary ice, or excessive scale buildup.

Intended Use

NORIOTA commercial undercounter ice machines are designed to automatically produce and temporarily store ice for commercial foodservice and beverage applications. These units are intended for indoor commercial use in restaurants, bars, cafés, hotels, catering operations, institutional kitchens, convenience stores, offices, break rooms, hospitality environments, and similar commercial applications where sanitary ice production is required.

These units are designed to produce slab-style full dice or half dice ice cubes using a vertical evaporator system and automatic harvest cycle. Ice produced by the unit is intended for beverage service, food display, food holding, ingredient preparation, and other commercial foodservice applications requiring clean, food-safe ice.

This equipment is intended for operation by trained commercial personnel familiar with safe food handling practices, basic cleaning procedures, and routine commercial equipment operation.

This unit is not intended for:

- Household or residential use

INTRODUCTION

- Outdoor installation
- Marine or mobile applications
- Laboratory or medical storage applications
- Long-term frozen storage
- Storage of food, beverages, chemicals, or other materials inside the ice storage bin
- Use in environments with excessive airborne grease, corrosive chemicals, flammable vapors, or uncontrolled environmental conditions

The ice storage bin is designed for temporary storage of produced ice only and is not a freezer. Ice will gradually melt during normal operation, especially during periods of low usage, high ambient temperatures, or frequent door opening.

Use of the unit outside its intended operating conditions may result in reduced performance, excessive maintenance requirements, unsanitary ice conditions, water leakage, equipment damage, or unsafe operation.

Manual Scope and Updates

This manual provides installation, operation, cleaning, maintenance, and troubleshooting guidance for NORIOTA commercial undercounter ice machines. It does not provide sealed refrigeration-system repair, refrigerant recovery, electrical diagnostics, compressor replacement, refrigerant charging, or advanced service procedures.

NORIOTA reserves the right to update specifications, design features, components, materials, software, control systems, or instructions without notice as part of ongoing product improvement.

Always refer to the unit rating label for the most current electrical, refrigerant, and technical information for the specific unit being serviced or installed.

Technical Information

Specification	ICE60U NI60F	ICE80U NI80F	ICE80UH NI80H	ICE100U NI100F	ICE100UH NI100H	ICE120U NI120F	ICE120UH NI120H
Electrical Supply	115 V / 60 Hz						
Rated Current (Ice Making / Harvest)	4.3 A / 3.0 A			3.8 A / 3.5 A			
Refrigerant	R290, 1.98 oz (56 g)	R290, 2.05 oz (58 g)	R290, 2.05 oz (58 g)	R290, 2.82 oz (80 g)	R290, 2.82 oz (80 g)	R290, 2.72 oz (77 g)	R290, 2.72 oz (77 g)
Ambient Operating Range	10 °C to 38 °C 50 °F to 100 °F						
Water Temperature Operating Range	4 °C to 32 °C 40 °F to 90 °F						
Water Pressure Operating Range	0.1 MPa to 0.55 MPa 15 to 80 PSI						
Ice Type	Full Dice Cube	Full Dice Cube	Half Dice Cube	Full Dice Cube	Half Dice Cube	Full Dice Cube	Half Dice Cube
Ice Cube Size	22 × 22 × 22 mm 7/8 × 7/8 × 7/8 in	22 × 22 × 22 mm 7/8 × 7/8 × 7/8 in	13 × 22 × 22 mm 1/2 × 7/8 × 7/8 in	22 × 22 × 22 mm 7/8 × 7/8 × 7/8 in	13 × 22 × 22 mm 1/2 × 7/8 × 7/8 in	22 × 22 × 22 mm 7/8 × 7/8 × 7/8 in	13 × 22 × 22 mm 1/2 × 7/8 × 7/8 in
Ice Per Cycle	32 cubes	44 cubes	72 cubes	55 cubes	90 cubes	70 cubes	115 cubes
Ice Production Capacity*	27 kg per day 60 lb per day	36 kg per day 80 lb per day		45 kg per day 100 lb per day		55 kg per day 122 lb per day	
Ice Storage Capacity	13.3 kg 29.3 lb			19.2 kg 42.3 lb			

*Ice production capacity tested under ambient temperature 21 °C (70 °F) and inlet water temperature 10 °C (50 °F). Actual production will vary based on installation environment, water temperature, and operating conditions.

RECEIVING AND INSPECTING THE EQUIPMENT

Carefully inspect the equipment immediately upon delivery and before installation. Transportation, handling, storage conditions, and movement during delivery may result in concealed or visible damage that is not immediately apparent until unpacking or installation.

Do not discard packaging materials until inspection is complete and the unit has been confirmed to be in acceptable condition. If shipping damage, concealed damage, missing components, water leakage, refrigeration tubing damage, electrical damage, or other abnormal conditions are identified, report the issue promptly to the carrier, dealer, or NORIOTA support.

Important Handling Notes

- Keep the unit upright during transportation, handling, movement, and installation at all times. Do not lay the unit on its side or upside down.
- Do not tip, drop, strike, or subject the unit to excessive impact during unloading or movement.
- Use appropriate equipment and sufficient assistance when unloading, lifting, or moving the unit.
- Do not lift, pull, or move the unit by the power cord, plug, door, handle, control panel, water connections, drain connections, or airflow openings.
- Protect the door, control panel, condenser airflow openings, power cord, plug, adjustable feet, water connections, and drain connections during handling and setup.

Receiving Inspection

When the shipment arrives:

- Inspect exterior packaging, pallet, straps, wrap, and visible shipping materials before acceptance.
- Check for signs of impact, punctures, crushing, tipped handling, torn packaging, water exposure, broken foam, loose contents, damaged pallet, missing straps, or other evidence of mishandling in transit.
- If visible damage is found, photograph the packaging, pallet, shipping label, and damaged areas before unpacking whenever practical.
- If a delivery receipt, bill of lading, courier device, or delivery document is provided, note the damage in as much detail as possible before signing, if applicable.

Concealed Damage Inspection

Perform concealed damage inspection as soon as possible after delivery and unpacking. Freight carriers and delivery providers may limit the time allowed to report concealed shipping damage.

After unpacking:

- Inspect all cabinet panels, internal components, refrigeration lines, fittings, drain connections, and electrical areas carefully.
- Verify the unit sits level and stable without cabinet distortion and the door opens and closes normally.
- Verify there are no unusual odors, residue, loose components, broken fittings, or signs of refrigerant leakage and the condenser airflow openings are not crushed, blocked, or damaged.

If concealed damage is identified:

- Retain all packaging materials.
- Document the condition with photographs.
- Contact the carrier and equipment supplier promptly.
- Do not attempt refrigeration system repair or operate a damaged unit.

Reporting Damage

- **Visible damage:** Note the damage in as much detail as possible on the delivery receipt, bill of lading, courier device, or delivery document before signing whenever practical. Photograph exterior packaging, shipping label, pallet, and damaged areas before unpacking or discarding packaging materials. Report visible damage promptly after receipt.
- **Concealed damage:** Report concealed damage promptly after unpacking and inspection. Retain packaging materials and photograph the damaged unit, packaging, and any abnormal conditions.

Serial Number Information

The model number and serial number are located on the unit rating label. Always have the model number and serial number available when contacting NORIOTA, the seller, or an authorized service provider for parts, service, warranty support, technical assistance, or freight-related documentation.

SAFETY INFORMATION

Commercial undercounter ice machines operate with electrically powered refrigeration components, moving airflow, condenser fans, water circulation systems, drainage systems, ice harvest cycles, sharp metal components, stored ice, water connections, electrical components, and flammable refrigerant. Improper installation, operation, cleaning, sanitizing, maintenance, handling, or servicing may result in electrical shock, fire or explosion hazard, refrigerant exposure, water leakage, unsanitary ice, reduced ice production, equipment damage, property damage, or unsafe operating conditions. Read and follow all safety instructions in this manual before installing, operating, cleaning, sanitizing, moving, or servicing this equipment.

This section identifies important safety information throughout the manual. Additional warnings and cautions are provided in other sections where specific hazards exist.



This is the Safety Alert Symbol. This symbol alerts you to potential hazards that can injure or kill you and others. All safety messages will follow the Safety Alert Symbol and either the words “**DANGER**”, “**WARNING**” or “**CAUTION**”.



DANGER!

This symbol indicates a hazardous situation which will result in death or serious injury.



WARNING!

This symbol indicates a hazardous situation or unsafe practice which, if not avoided, could result in death or serious injury.



CAUTION!

This symbol indicates a potential hazard or unsafe condition that may result in injury, equipment damage, or property damage.



NOTICE!

This symbol indicates important information related to proper use, installation, or maintenance of the equipment that does not involve a personal injury hazard.

All safety messages identify the hazard, explain how to reduce the risk, and describe the possible consequences if instructions are not followed.



WARNING!

Electrical Shock Hazard

- Plug only into a properly grounded electrical outlet matching the voltage shown on the rating label.
- Do not immerse the unit, power cord, or plug in water or any other liquid.
- Do not spray, hose down, pressure clean, or steam clean the unit, control panel, power cord, plug, or electrical areas.
- Do not operate the unit with a damaged cord, damaged plug, damaged controls, damaged wiring, water intrusion, or signs of electrical malfunction.
- Disconnect power before cleaning, inspection, movement, maintenance, or service.



WARNING!

Flammable Refrigerant, Fire, and Explosion Hazard



- This unit contains R290 (propane) refrigerant, which is flammable.
- Do not puncture, cut, modify, kink, or damage refrigeration tubing or sealed system components.
- Do not use mechanical devices or sharp tools to remove ice or frost.
- Keep open flames, sparks, cigarettes, vapes, hot work, and other ignition sources away from unit.
- Do not store or use gasoline, aerosol cans, or other flammable vapors or liquids near this or any other electrical appliance.
- Refrigeration system service must be performed only by qualified service personnel trained to work with flammable refrigerants.
- Do not operate if refrigeration tubing is damaged or a refrigerant leak is suspected. Ventilate the area and contact qualified service personnel.
- Failure to follow these instructions may result in fire, explosion, or serious injury.

SAFETY INFORMATION



NOTICE!

- This equipment is intended for commercial foodservice use only. It is not intended for household, residential, or other non-commercial use.
- Installation, setup, electrical connection, water supply connection, drain connection, and service must be performed by qualified personnel in accordance with this manual and all applicable local codes and regulations.
- Use of non-approved parts, improper installation, improper drainage, blocked airflow, unauthorized service, or operation outside the conditions described in this manual may result in unsafe conditions and may affect warranty coverage.

General Safety Instructions

- Read this manual completely before installing, operating, cleaning, sanitizing, moving, or servicing unit.
- Do not operate the unit if it has been damaged, dropped, improperly handled, exposed to excessive moisture, or shows signs of unsafe operation.
- Do not operate the unit with damaged refrigeration tubing, damaged wiring, damaged controls, damaged water connections, damaged drain connections, damaged airflow openings, or missing components.
- Keep all ventilation openings, condenser airflow areas, and service clearances unobstructed at all times.
- Do not block the front grille or restrict condenser airflow. Restricted airflow may reduce ice production, increase operating temperatures, and shorten component life.
- Connect only to a potable water supply within the operating conditions specified in this manual.
- Maintain proper gravity drainage at all times. Improper drainage may result in water leakage, unsanitary conditions, or equipment damage.
- Do not spray, hose down, pressure clean, or steam clean the unit.
- Do not store gasoline, aerosol cans, or flammable vapors or liquids near the equipment.
- Do not store food, bottles, chemicals, packaging, tools, or non-ice items in the ice storage bin.
- Do not place or operate electrical appliances, accessories, heaters, tools, or non-approved devices inside the ice storage bin or ice-contact areas.
- Clean and sanitize the unit regularly following the procedures in this manual.
- Discard ice after startup, cleaning, shutdown, or any condition affecting sanitation.
- Keep the door closed during normal operation except when removing ice. Frequent or extended door opening may increase ice melting and affect ice formation.
- Do not attempt refrigeration system repair, refrigerant handling, electrical diagnostics, control programming, or sealed-system service unless properly qualified.
- This equipment is not intended for use by children or untrained persons. Children should be supervised and must not play with, clean, or maintain the equipment.
- Keep this manual accessible to operators and service personnel for future reference.

Electrical Safety



WARNING!

Improper electrical connection, damaged cords, lack of grounding, water intrusion, wet electrical components, or unauthorized electrical service may result in electrical shock, fire, equipment damage, serious injury, or death.

- Do not cut, remove, modify, or bypass the grounding prong on the power cord.
- If grounding, outlet condition, circuit capacity, or electrical-code compliance is uncertain, have the outlet and circuit inspected by a qualified electrician before use.
- Disconnect power before cleaning, sanitizing, inspection, maintenance, movement, or service.
- Do not use extension cords, adapters, power strips, damaged outlets, or ungrounded electrical connections.
- Do not connect or disconnect the power plug with wet hands.
- When unplugging the unit, grasp the plug firmly and pull straight out from the outlet. Do not unplug the unit by pulling on the power cord.
- If the power cord is damaged, it must be replaced only by qualified service personnel using an approved replacement cord or assembly.
- Ensure the unit is not resting on, pinching, bending sharply, or damaging the power cord during installation, movement, or operation.
- Keep electrical components and wiring areas dry during operation, cleaning, and maintenance.
- Allow several minutes after unplugging the unit or after a power interruption before reconnecting power to help protect the refrigeration system from short cycling.

SAFETY INFORMATION

- Electrical service, wiring repair, internal diagnostics, control replacement, and power cord replacement must be performed only by qualified service personnel.

Flammable Refrigerant Safety



WARNING!

Punctured refrigeration tubing, refrigerant leakage, ignition sources, unauthorized or improper refrigeration service, or use of non-approved refrigeration components may result in fire, explosion, equipment damage, serious injury, or death.

- This equipment contains R290 (propane) refrigerant, which is flammable.
- Do not use mechanical devices, sharp tools, or heat sources to remove ice or frost from refrigeration components.
- Do not store or use gasoline, aerosol cans, or other flammable vapors or liquids near the equipment.
- Do not install or operate the equipment next to continuously operating ignition sources, open flames, operating gas appliances, electric heaters, or areas where flammable vapors may be present.
- If refrigerant leakage is suspected, avoid flames, sparks, and ignition sources, ventilate the area, and contact qualified service personnel immediately.

Service and Repair Restrictions

R290 is a flammable refrigerant that requires specialized handling procedures and qualified service personnel familiar with flammable refrigeration systems.

- Do not puncture, cut, braze, heat, modify, or damage refrigerant tubing or refrigeration components.
- Do not use open flames, ignition sources, or unapproved leak-detection near refrigeration system.

Only qualified service personnel trained for flammable refrigerant systems should perform refrigerant recovery, leak detection, brazing or sealed-system repair, compressor replacement, refrigerant charging or evacuation, refrigeration-system disassembly or modification.

If refrigerant tubing becomes damaged or a refrigerant leak is suspected:

- Avoid flames, sparks, and ignition sources.
- Do not plug in, unplug, switch on, or switch off electrical devices near the suspected leak.
- Ventilate the area and contact qualified service personnel immediately.

Water Supply, Drain, and Leak Prevention Safety



CAUTION!

Improper water supply connection, drain installation, water shutoff, blocked drainage, leaking fittings, or operation outside the specified water conditions may result in water leakage, unsanitary ice, slip hazard, equipment damage, property damage, or unsafe operating conditions.

- Connect only to a potable water supply.
- Water pressure and inlet water temperature must remain within specified limits.
- This unit is designed for gravity drain operation. Ensure the drain line slopes downward continuously and is not kinked, pinched, restricted, frozen, blocked, or submerged.
- Do not route the drain line upward or create low spots, restrictions, or configurations that prevent proper gravity drainage.
- Maintain an air gap at the drain termination where required by local plumbing code.
- Check all water supply and drain connections for leaks after installation, after moving the unit, after cleaning, and during routine maintenance.
- Do not operate the unit if water leakage, drain backup, standing water, cracked fittings, damaged tubing, or loose connections are observed.
- Keep the water supply open during operation. Do not shut off the water supply while the unit is operating.
- Follow the cleaning procedure exactly. Some cleaning procedures require the unit to remain connected to the water supply during the cleaning cycle.
- Shut off water supply and disconnect power before service, extended shutdown, or if a leak is observed.
- Clean up spilled water immediately to reduce slip hazards.

Mechanical, Moving Part, and Surface Safety



CAUTION!

Contact with moving components, sharp metal surfaces, cold refrigeration surfaces, warm internal components, or falling ice may result in cuts, pinch injury, impact injury, burns, cold-contact injury, or unsafe operating conditions.

- Keep hands, tools, loose clothing, jewelry, and foreign objects away from moving parts during operation.
- Do not reach into the ice drop area during ice harvest operation.
- Fans, pumps, valves, and mechanical components may start automatically during normal operation.
- Do not remove panels, guards, covers, or service access components while the unit is operating.

SAFETY INFORMATION

- Sheet metal edges are sharp. Use caution during cleaning or inspection.
- Certain internal components may become warm during normal operation. Allow components to cool before cleaning, inspection, or maintenance.
- Certain internal refrigeration components and evaporator surfaces may become cold during operation. Avoid direct contact during or immediately after operation.
- Do not use sharp tools, scrapers, knives, or mechanical devices to remove ice or frost from internal components or bin.
- If ice is stuck on the evaporator or ice slideway area, turn the unit off and allow ice to release or melt naturally. Do not force ice from the evaporator.

Equipment Handling and Misuse



CAUTION!

Improper handling, unstable placement, unauthorized modification, missing components, misuse, or operation outside this manual may result in personal injury, water leakage, equipment damage, unsafe operation, or affected warranty coverage.

- The unit is heavy and may tip if not handled correctly.
- Use appropriate equipment and sufficient personnel when unloading, moving, or positioning the unit.
- Do not lift, pull, push, or move the unit by the door, handle, feet, control panel, panels, power cord, water connections, drain connections, ice slideway, or internal components.
- Keep the unit upright during handling and movement. Do not lay the unit on its side or upside down.
- Do not modify the unit, plug, grounding system, refrigeration system, water system, drain system, controls, panels, guards, or safety devices.
- Do not remove panels, guards, covers, or safety devices except as instructed for operator-level cleaning or maintenance.
- Do not store food, bottles, chemicals, packaging, tools, or non-ice items in the ice storage bin.

Ice Handling and Food Safety



CAUTION!

Ice is a food-contact product. Improper ice handling, contaminated scoops, foreign objects in the ice bin, or unsanitary storage conditions may result in unsafe ice, contamination, illness risk, or equipment damage.

- Use only clean utensils or an approved ice scoop to remove ice.
- Do not use bare hands to remove ice from the bin.
- Store the ice scoop in a clean, sanitary location when not in use.
- Do not store bottles, cans, food, chemicals, tools, packaging, or non-ice items in the ice storage bin.
- Keep the door closed when ice is not being removed.
- Discard first two batches of ice or more as needed after installation, cleaning, sanitizing, extended shutdown, service, or suspected contamination.
- Clean and sanitize the ice storage bin as instructed in this manual.

Cleaning and Sanitation Safety



WARNING!

Failure to disconnect power, follow proper cleaning and sanitizing procedures, or use approved cleaning methods may result in electrical shock, unsanitary ice, chemical exposure, equipment damage, water leakage, or unsafe operating conditions.

- Disconnect power before manual cleaning, inspection, maintenance, or service unless a specific cleaning or sanitizing procedure in this manual instructs that power must remain connected for a controlled cleaning cycle.
- Allow moving components and refrigeration surfaces to stabilize before cleaning or inspection.
- Do not immerse the unit, power cord, or plug in water or any other liquid.
- Do not spray, hose down, pressure clean, or steam clean the unit, control panel, condenser area, power cord, plug, or electrical components.
- Prevent water, cleaning chemicals, scale remover, sanitizer, grease, or debris from entering electrical areas, controls, wiring, fan areas, or airflow openings.
- Use only cleaning and sanitizing products suitable for commercial ice machine use.
- Use only nickel-safe ice machine cleaner suitable for nickel-plated evaporator systems.
- Do not use steel wool, metal scrapers, abrasive pads, highly corrosive cleaners, or chemicals not intended for commercial ice machines or stainless steel surfaces.
- Do not mix cleaning chemicals, sanitizers, chlorine products, or acids.

SAFETY INFORMATION

- Rinse and dry surfaces thoroughly after cleaning and sanitizing procedures whenever required.
- Do not leave cleaning solution, sanitizer, or chemical residue inside the water system or ice storage bin after cleaning. Complete all required rinse and drain steps before returning the unit to service.
- Always discard the first two batches of ice after installation, cleaning, sanitizing, recommissioning, extended shutdown, or any condition that may affect ice sanitation.
- If the unit has been exposed to excessive water intrusion, discontinue use and contact qualified service personnel before reconnecting power.

Service and Repair Safety



WARNING!

Improper service, unauthorized modification, incorrect replacement parts, or unauthorized refrigeration system work may result in electrical shock, fire or explosion hazard, refrigerant leakage, equipment damage, unsafe operation, serious injury, or affected warranty coverage.

- Internal electrical service and refrigeration system service must be performed by qualified service personnel only.
- Do not attempt to repair, modify, bypass, or alter refrigeration components, controls, wiring, fan components, sensors, compressor components, sealed-system components, or safety devices.
- Disconnect power before inspection, maintenance, service, or replacement of components.
- Use only approved replacement parts suitable for the specific model being serviced.
- Do not operate the unit with damaged wiring, damaged refrigeration tubing, loose electrical connections, damaged controls, damaged airflow openings, missing panels, damaged ice slideway, water leakage, or abnormal operation.
- If abnormal odor, refrigerant leakage, smoke, sparking, repeated breaker tripping, fan failure, compressor overheating, electrical malfunction, or water intrusion occurs, discontinue use and contact qualified service personnel immediately.
- Do not modify the plug, grounding system, electrical supply configuration, refrigeration system, controls, airflow system, or drain system.
- Refrigerant handling, recovery, sealed-system repair, charging, and diagnostics must be performed only by personnel trained to work with flammable R290 refrigerant systems.
- After service, cleaning, inspection, or maintenance, confirm all covers, guards, fasteners, panels, drain connections, and components are properly reinstalled before operation. Do not operate the unit with panels, guards, covers, or required components removed.

Unit Disposal



CAUTION!

Improper disposal, handling, abandonment, or removal from service may result in electrical hazard, refrigerant hazard, cuts, entrapment hazard, environmental concerns, equipment damage, or regulatory non-compliance.

- Disconnect the unit from the electrical supply before disposal, transport, storage, or removal from service.
- Do not leave discarded equipment accessible to children or unauthorized persons.
- Remove or secure the door if the unit is being stored, discarded, or left unattended before disposal. Remove the door before final disposal whenever required by local regulations.
- Use caution when handling sheet metal panels, door components, condenser areas, refrigeration components, adjustable feet, and internal metal components during removal or disposal.
- Dispose of the unit in accordance with all applicable local, provincial, state, and federal regulations.

Refrigerant Disposal



WARNING!

Improper handling, venting, recovery, or disposal of flammable refrigerant may result in fire, explosion, environmental hazard, serious injury, or death.

- This unit contains a sealed refrigeration system using R290 refrigerant (propane).
- Do not puncture, cut, heat, or damage refrigeration tubing or sealed-system components during removal or disposal.
- Refrigerant recovery and sealed-system handling must be performed only by qualified service personnel trained to work with flammable refrigerants.
- Refrigerant, compressor oil, refrigeration components, and related materials must be recovered, handled, recycled, or disposed of in accordance with all applicable local, provincial, state, and federal regulations.
- Deliver discarded equipment to an authorized recycling, recovery, or collection facility in accordance with applicable regulations.

INSTALLATION

Proper installation is essential for safe operation, electrical safety, refrigeration system performance, airflow, drainage, ice production consistency, sanitation, leak prevention, and long equipment life. Improper installation, unstable placement, blocked airflow, improper electrical supply, improper water supply connection, improper drain installation, failure to maintain required clearances, or failure to follow installation requirements may result in electrical shock, fire hazard, refrigerant hazard, water leakage, unsanitary ice, reduced ice production, equipment damage, property damage, or unsafe operating conditions.

Installation, setup, electrical connection, water supply connection, drain connection, inspection, and service must be performed in accordance with this manual and all applicable local codes and regulations. Read the entire installation section before connecting power, turning on the water supply, or placing the unit into service.

Installation Responsibility and Code Compliance



Improper electrical connection, incorrect voltage supply, lack of grounding, improper water or drain installation, damaged wiring, unstable placement, blocked airflow, or failure to follow applicable codes may result in serious injury, death, fire hazard, electrical shock, water leakage, equipment damage, or unsafe operating conditions.

- Installation, electrical connection, water supply connection, drain connection, and service must be performed in accordance with this manual and all applicable local codes and regulations.
- Electrical installation must comply with applicable electrical codes and authority requirements.
 - In Canada, electrical installation must comply with CSA C22.1, Canadian Electrical Code, and applicable local authority requirements.
 - In the United States, electrical installation must comply with ANSI/NFPA 70, National Electrical Code, and applicable local authority requirements.
- Water supply and drain installation must comply with applicable plumbing, sanitation, drainage, and backflow-prevention requirements.
- Refrigeration system service should comply with applicable refrigeration safety regulations including ANSI/ASHRAE 15, Safety Standard for Refrigeration Systems, where applicable.

Pre-Installation Checklist

Before installing or operating the unit, review and confirm the following:

Site and Placement Preparation

- Ambient room temperature remains within the operating range specified in this manual.
- Front grille and condenser airflow areas will remain unobstructed during operation.
- Installation location allows access for cleaning, inspection, service, airflow, water connections, and drain connections.
- Unit is not installed adjacent to ovens, grills, fryers, steam equipment, or other major heat-producing equipment whenever possible.
- Drainage routing has been planned to prevent standing water, drain restrictions, or water overflow.
- Protect finished flooring before moving the unit into final position.

Electrical Preparation

- Electrical supply matches the voltage and frequency shown on the unit rating label.
- Electrical circuit capacity is appropriate for the unit and complies with applicable electrical codes.
- Outlet, grounding, and electrical supply have been inspected by a qualified electrician if required.
- Extension cords, adapters, power strips, and multi-outlet devices will not be used.
- Power cord can be routed safely without pinching, sharp bends, abrasion, or contact with hot surfaces.

Water Supply and Drain Preparation

- Water pressure and inlet water temperature are within the operating range specified in this manual.
- Water shutoff valve is accessible after installation.
- Drain line routing will maintain continuous downward slope without kinks, loops, restrictions, or submerged drain termination.
- Drain system complies with applicable plumbing, sanitation, and backflow-prevention requirements.
- All required water supply fittings, tubing, drain tubing, and installation accessories are available.

Unit Inspection Before Installation

- All packaging materials, protective film, tape, and shipping restraints have been removed.
- Power cord, plug, water and drain connections, door, and airflow openings are undamaged.
- Adjustable feet are properly installed and capable of leveling the unit.

INSTALLATION

- Interior ice storage bin is clean and free from packaging materials or foreign objects.
- User manual and required documentation are available to operators and installers.

Before Initial Startup

- Unit has remained upright during transport and positioning. If the unit has been tilted, laid on its back or side, or transported non-upright, allow it to stand upright for at least 24 hours before plugging in.
- Unit is level and stable in final operating position.
- Water supply has been turned on before startup.
- Installation area is clean and free from combustible materials and installation debris.
- Operators have reviewed the installation, operation, cleaning, and safety instructions in this manual.

Compressor Settling Time



NOTICE!

If the unit was tilted excessively, laid on its side or back, or transported in a non-upright position, allow the unit to remain upright and disconnected from power for at least 24 hours before operating. If the unit remained upright during transport and positioning, allow a minimum of 10 minutes before powering on.

Unpacking and Packaging Removal



CAUTION!

Failure to remove packaging materials, shipping restraints, or protective coverings may result in blocked airflow, abnormal operation, water leakage, unsanitary ice, equipment damage, or unsafe operating conditions.

Carefully remove all packaging materials, tape, protective film, shipping supports, and accessories before installation or operation. Failure to remove packaging materials, shipping restraints, or protective coverings may restrict airflow, interfere with operation, damage components, or create unsafe operating conditions.

- Inspect the unit and packaging for visible or concealed shipping damage before installation.
- Remove all exterior and interior packaging materials, protective film, tape, foam, cardboard, plastic ties, and shipping restraints before connecting power or water.
- Remove all accessories, documentation, adjustable feet, and packaged components from the ice storage bin before operation.
- Do not remove the rating label, serial number label, warning labels, permanent instruction labels, or certification labels from the unit.
- Inspect the interior bin area, evaporator area, ice slideway, drain area, and airflow openings for loose packaging materials or debris before startup.
- Clean the interior ice storage bin and accessible food-contact surfaces before first use following the cleaning instructions in this manual.
- Do not use sharp tools, knives, abrasive pads, flammable liquids, or aggressive chemicals to remove packaging materials or adhesive residue.
- If adhesive residue remains after film or tape removal, use a soft cloth and a cleaner suitable for stainless steel surfaces.
- Confirm all panels, door, drain and water lines, and removable parts are properly installed.

Location and Placement Requirements



CAUTION!

Improper installation location, unstable placement, blocked airflow, excessive heat exposure, outdoor installation, or operation outside recommended environmental conditions may result in reduced ice production, water leakage, excessive melting, refrigeration system stress, equipment damage, or unsafe operating conditions.

- This unit is intended for indoor commercial use only.
- Install the unit in a clean, dry, well-ventilated location protected from rain, direct weather exposure, water spray, standing water, excessive humidity, freezing conditions, and outdoor environments.
- Do not store, install, or operate the unit in a location with continuously operating ignition sources, open flames, operating gas equipment, electric heaters, or areas where flammable vapors may be present. This unit contains R290 refrigerant, which may not contain an odor that reliably indicates a leak.
- Install the unit on a stable, level surface capable of supporting the combined weight of the unit, water, and stored ice during operation.
- Ambient room temperature must remain within the operating range specified in this manual.

Requirement	Specification
Ambient operating range	10 °C to 38 °C (50 °F to 100 °F)

INSTALLATION

- Do not install the unit adjacent to ovens, grills, fryers, steam equipment, dishwashers, or other major heat-producing equipment whenever possible.
- Do not install the unit in direct sunlight or in locations exposed to excessive radiant heat.
- Ensure the installation location provides adequate ventilation and required airflow clearances for proper condenser cooling and service access.
- Keep the front grille and condenser airflow openings unobstructed at all times.
- Allow sufficient access for cleaning, inspection, drain, water, and electrical connection, and service.
- The installation location should allow the unit to be pulled forward for service when necessary.
- Ensure the power plug, water shutoff valve, and drain connections remain accessible after installation.
- Do not install the unit in locations where water leakage or drain overflow could create slip hazards or property damage.

Free-Standing and Built-In Installation



CAUTION!

Improper built-in or enclosed installation, restricted airflow, or damaged water, drain, or electrical connections may result in reduced ice production, overheating, water leakage, equipment damage, or unsafe operating conditions.

This unit may be installed as a free-standing unit or in a built-in or enclosed installation provided that required ventilation clearances, and airflow, electrical, water supply, and drain requirements are maintained.

Free-Standing Installation

- Install the unit on a stable, level surface capable of supporting the combined weight of the unit, water, and stored ice during operation.
- Ensure all required ventilation and service clearances are maintained.
- Confirm the front grille and condenser airflow openings remain completely unobstructed.
- Ensure access to the electrical outlet, water supply connection, shutoff valve, and drain connection after installation.
- Verify the installation location allows adequate airflow, cleaning access, inspection access, and future service access.
- For free-standing installation, either the factory-installed short feet or the included raised adjustable legs may be used, provided the unit is level, stable, and accessible for cleaning.

Built-In or Enclosed Installation

- Select the factory-installed short feet or included raised adjustable legs based on the finished counter height and required cleaning access.
- Built-in or enclosed installation requires adequate ventilation space around the unit for proper condenser airflow and service access.
- Water supply and drain connections should be completed before moving the unit into final installation position whenever practical.
- Turn on the water supply and inspect all water and drain connections for leaks before final positioning.
- Ensure the power cord, water tubing, and drain tubing are not kinked, pinched, crushed, or damaged during installation.
- Confirm the front grille remains completely unobstructed after installation.
- Do not seal the unit into cabinetry or enclosures in a way that prevents proper airflow, inspection, cleaning, or future service access.
- Ensure the unit can be pulled forward for cleaning, inspection, and service if necessary.
- If the unit cannot be pulled forward for cleaning underneath and around the base, seal all around the base of the unit to the floor using an approved caulking compound.

Clearance and Ventilation Requirements



NOTICE!

Blocked airflow, restricted ventilation, or excessive ambient temperatures may result in reduced ice production, excessive ice melting, longer run times, refrigeration system stress, compressor damage, or shortened equipment life.

Proper airflow is essential for normal refrigeration system operation, ice production capacity, energy efficiency, and long equipment life. Restricted airflow may reduce ice production, increase operating temperatures and energy usage, shorten component life, or result in abnormal operation.

Minimum Clearance Requirements

- **Rear:** 102 mm (4 in) minimum
- **Top:** 15 mm (0.6 in) minimum, additional clearance recommended when available
- **Sides:** 15 mm (0.6 in) minimum, additional clearance recommended when available
- **Front:** keep fully open and unobstructed for condenser airflow, air filter access, cleaning, and service

INSTALLATION

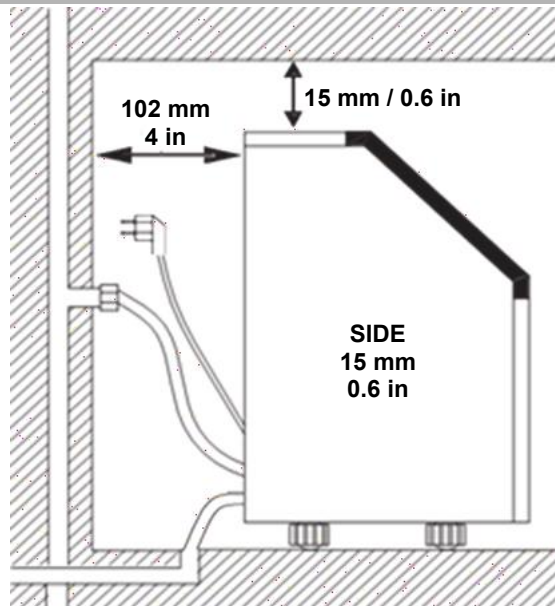

Figure A – Clearance Diagram

The unit may still operate with reduced side clearance in some installations provided the front airflow path remains unobstructed and adequate ventilation is maintained. However, reduced side airflow may decrease ice production capacity, increase operating temperatures and energy usage, and reduce overall refrigeration system efficiency compared to installations with more open airflow around the unit.

- Do not block, cover, or restrict the front grille or condenser airflow openings.
- Do not store boxes, packaging, towels, liners, filters, or other materials against airflow openings or condenser areas.
- Do not install the unit in tightly enclosed spaces with inadequate ventilation.
- Keep the surrounding installation area clean and free from dust, grease, lint, flour, and airborne debris that may restrict condenser airflow.
- Higher ambient temperatures, poor ventilation, and restricted airflow may increase cleaning frequency requirements and reduce overall performance.
- Allow sufficient space to pull the unit forward for inspection, cleaning, and service when necessary.

Leveling and Adjustable Feet



CAUTION!

The unit becomes significantly heavier during operation and when loaded with water and ice. Improper leveling or unstable placement may result in abnormal operation, water leakage, excessive vibration, or equipment damage.

Proper leveling is essential for normal drainage, water distribution, ice release, harvest operation, and overall performance. Operating the unit while out of level may result in water leakage, abnormal ice formation, incomplete harvest cycles, increased noise, or reduced ice production.

This unit may be supplied with more than one type of adjustable foot. Depending on the model and installation requirement, shorter feet may be used for lower counter installations, and taller feet may be used for standard-height counter installations. Always use the foot type appropriate for the installation location and confirm the installed height before final positioning.

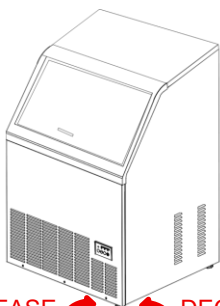

INCREASE HEIGHT  DECREASE HEIGHT 

Figure B – Adjusting the Feet

To Level:

1. Place the unit on a stable surface.
2. Adjust the four adjustable feet by rotating:
 - i. Rotate clockwise to increase machine height
 - ii. Rotate counter-clockwise to decrease machine height
3. Use a carpenter's level to verify that the unit is level front-to-back and side-to-side.
4. Confirm that the unit is stable and does not rock.

- Keep the unit upright during movement, positioning, and leveling.

INSTALLATION

- Install only the adjustable feet supplied or approved for the unit.
- Confirm all feet are securely attached, properly seated, and threaded evenly before operation.
- Position the unit on a stable, level surface capable of supporting the combined weight of the unit, water, and stored ice during operation.
- Ensure all feet are fully supporting the unit and making firm contact with the floor.
- Recheck leveling after final positioning, water connection, and drain connection.
- Recheck leveling if the unit is moved, repositioned, or relocated.
- Confirm the unit can be installed without pinching the power cord, water line, or drain line.
- Confirm the selected foot height allows required ventilation clearances, proper drainage, and service access.

Electrical Supply Requirements

Improper electrical supply, incorrect voltage, inadequate grounding, damaged wiring, overloaded circuits, or failure to follow electrical requirements may result in electrical shock, fire hazard, equipment damage, or unsafe operation.

- Verify the electrical supply matches the voltage, frequency, and electrical requirements shown on the rating label before connecting power.
 - The rating label on the unit overrides general electrical information in this manual.
- This unit requires a properly grounded electrical supply.
- Connect the unit only to a dedicated properly grounded outlet of the correct voltage and circuit capacity.
 - In the United States, electrical installation must comply with ANSI/NFPA 70, National Electrical Code, and applicable local authority requirements.
 - In Canada, electrical installation must comply with CSA C22.1, Canadian Electrical Code, and applicable local authority requirements.
- The power plug must remain accessible after installation so the unit can be disconnected from power when required.
- Use an outlet that cannot be turned off by a wall switch, pull chain, timer, or power-control device.
- Do not remove, modify, or bypass the grounding prong.
- Do not use extension cords, adapters, power strips, multi-outlet devices, or shared circuits.
- Do not connect the unit to an incorrect voltage supply or improperly sized electrical circuit.
- The electrical circuit, fuse, or circuit breaker must be properly sized for the ice machine model according to the rating label and applicable electrical codes.
- If grounding, outlet condition, circuit capacity, or electrical-code compliance is uncertain, have the outlet and circuit inspected by a qualified electrician before operation.
- Ensure the power cord is routed safely and is not pinched, crushed, sharply bent, or damaged during installation or operation.
- Allow several minutes after unplugging the unit or after a power interruption before reconnecting power to help protect the refrigeration system from short cycling.
- Use of GFI/GFCI protection may be required by local code. Where required, GFI/GFCI protection must be selected and installed by a qualified electrician. Some GFI/GFCI devices may nuisance trip with commercial refrigeration equipment. Do not bypass required electrical protection devices.
- Internal electrical service, wiring repair, controller replacement, refrigeration system service, and component replacement must be performed only by qualified service personnel.

Water Supply Requirements



CAUTION!

Improper water supply installation, damaged tubing, leaking fittings, excessive water pressure, restricted flow, or operation outside recommended water conditions may result in water leakage, reduced ice production, poor ice quality, excessive scale buildup, equipment damage, or unsafe operating conditions.

- Connect only to a potable cold-water supply.
- Water supply installation must comply with applicable plumbing, sanitation, drainage, and backflow-prevention requirements.
- Water pressure and inlet water temperature must remain within operating range specified in this manual.
- The water supply should include an accessible shutoff valve near the installation location.
- This ice machine is designed for connection to a standard 1/4 in OD water supply tube.
- Flush the water line before connecting it to the unit to remove debris that could clog internal water components.
- Inspect all tubing, fittings, valves, and water connections for damage before installation.
- Ensure all water connections are secure before turning on the water supply.
- Turn on the water supply and inspect all fittings and tubing carefully for leaks before operating the unit.

INSTALLATION

- Reinspect all water connections after final positioning and during initial operation.
- Do not kink, sharply bend, crush, stretch, or damage water supply tubing during installation or operation.
- Keep the water supply turned on during operation. Do not shut off the water supply while the unit is operating.
- Shut off the water supply before extended shutdown, service, relocation, or if leakage is observed.
- Water supply conditions outside the recommended operating range may reduce ice production, affect ice quality, increase scale buildup, or affect normal operation.

Operating Water Conditions

Requirement	Specification
Water Supply	Potable cold water
Water Pressure	0.1 MPa to 0.55 MPa (15 to 80 PSI)*
Water Temperature	4 °C to 32 °C (40 °F to 90 °F)
Water Connection	1/4 in OD water tubing

*NOTE: Incoming water pressure above 0.55 MPa (80 PSI) requires installation of a suitable water pressure regulator before the unit and filtration system.

Water Pressure and Flow

Proper water pressure and flow are required for normal fill, freeze, harvest, and cleaning operation. Water supply pressure must remain within the operating range specified above.

- Low water pressure or restricted flow may cause slow fill times, reduced ice production, incomplete or irregular cube formation, longer freeze cycles, or lack-of-water fault notifications.
- Excessive water pressure above 0.55 MPa (80 PSI) may cause internal leakage, valve stress, fitting leaks, abnormal water flow, or premature wear of water-system components
- Flush the water line before connection and inspect tubing, fittings, shutoff valves, and the included sediment filter for restrictions.

If water pressure is outside specification, unstable, or unknown, consult a **qualified installer** or **plumber** before operating the unit.

Water Treatment Cautions

Softened water may result in white, soft, or mushy ice cubes that stick together. Deionized water is not recommended because it may negatively affect ice formation and normal system operation.

Reverse osmosis systems may reduce water pressure below the minimum pressure required for proper ice machine operation. If an RO system is used, confirm that water pressure and flow remain within the specified operating range at the ice machine inlet.

Included Sediment Filter and Water Filtration



NOTICE!

The included sediment filter is a sediment filter only. It is not an anti-scale filter and does not control water hardness, dissolved mineral content, or scale formation. For best ice machine performance, a commercial ice-machine-rated filtration system with scale inhibition is strongly recommended, especially in areas with hard water, high mineral content, taste or odor issues, or variable water quality.

This unit includes an external PP sediment filter for installation in the incoming water line. The sediment filter helps reduce incoming dirt, rust, and particulate matter before water enters the unit.

Included Sediment Filter Specifications

Filter type	PP sediment filter
Housing material	PP (polypropylene)
Rated flow rate	64 L/min (17 gal/min)
Water temperature range	4.5 °C to 37.7 °C (40 °F to 100 °F)
Water pressure range	0.1 MPa to 0.55 MPa (15 to 80 PSI)

Sediment Filter Installation

- The sediment filter should be used only with potable cold water.
- The sediment filter should be installed by a professional.

INSTALLATION

- Install the sediment filter in the incoming water supply line before the water connects to the unit.
- Use the included quick-connect fittings and water tubing components supplied with the unit.
- Confirm the water flow direction matches the In / Out markings shown on the filter label.
- Flush the water supply line before installing the filter.
- After installing the filter, turn on the water supply slowly and check all fittings for leaks.
- Confirm tubing is fully seated in each quick-connect fitting.
- Do not kink, pinch, sharply bend, or strain the tubing.
- Do not install the filter where it may be exposed to freezing, heat, grease, impact, or physical damage.
- Position the filter where it can be accessed for inspection and replacement.
- If the water pressure is higher than 0.55 MPa (80 PSI), install a pressure-reducing valve before the filter and ice machine.

Filter Replacement

The included sediment filter should be replaced every 6 months under normal conditions. Replacement frequency may vary depending on water quality, sediment level, usage, and local conditions. Replace the filter sooner if:

- Water flow appears reduced
- Ice production slows
- Sediment or discoloration is visible
- The filter appears clogged, restricted, damaged, or leaking
- The unit has been out of service for an extended period

Do not operate the unit with a clogged, damaged, leaking, frozen, or improperly installed filter.

Scale Awareness

Mineral scale is a normal result of ice production in hard water or high-mineral water conditions. As water freezes, minerals remain in the water system and can build up on internal surfaces over time. The included sediment filter helps reduce incoming particles and debris, but it does not remove dissolved minerals or prevent scale formation. Even when filtration is used, periodic descaling is required.

Signs that scale may be accumulating include:

- Inconsistent ice thickness
- Reduced ice production
- Longer freeze cycles
- Incomplete or irregular cube formation
- White mineral deposits visible inside the water system
- Increased cleaning frequency required to maintain performance

Run the **Cleaning Cycle** at recommended intervals and more often if local water conditions require it. Failure to remove scale may reduce performance, increase energy usage, affect ice quality, and shorten component life.

Drain Requirements

Improper drain installation, restricted drainage, incorrect drain routing, or failure to maintain proper drain slope may result in water leakage, unsanitary conditions, ice melting problems, property damage, reduced performance, or unsafe operating conditions.

This unit is designed for gravity drain operation only. The drain outlet is designed for use with a 3/4 in ID drain hose. The supplied drain hose is approximately 1.5 m (5 ft) long. Proper drainage is essential for normal operation, cleaning cycles, harvest cycles, melted ice removal, and long-term sanitation.

- Drain installation must comply with applicable plumbing, sanitation, drainage, and backflow-prevention requirements.
- The drain system should be roughed in and ready before final installation whenever practical.
- Install the drain line so water flows continuously downward from the unit to the building drain.
- Do not kink, crush, sharply bend, stretch, restrict, or damage the drain tubing.
- Do not route the drain line upward or create loops, traps, low spots, or standing-water sections that may restrict drainage.
- Never allow the drain hose to hang or loop higher than the floor of the ice storage bin.
- All horizontal drain runs should maintain a minimum downward slope as follows:

INSTALLATION

Requirement	Specification
Drain connection	3/4 in ID
Minimum downward slope for drain line	6 mm per 300 mm (1/4 in per ft)

- If the supplied drain hose is used, locate the building drain close enough to maintain continuous downward slope without stretching, looping, kinking, or routing the hose upward.
- Maintain an air gap at the drain termination where required by local plumbing code.
- Do not connect the drain hose directly to a closed drain system without an approved air gap or code-compliant indirect waste connection.
- Ensure the drain outlet, drain hose, and building drain are capable of handling normal ice melt, cleaning water, and harvest-cycle drainage.
- A floor drain or properly trapped standpipe may be used where permitted by local code.
- If gravity drainage is not available, consult a qualified installer or plumber regarding approved drain solutions.
- Do not operate the unit if drainage is restricted, leaking, backed up, frozen, or disconnected.

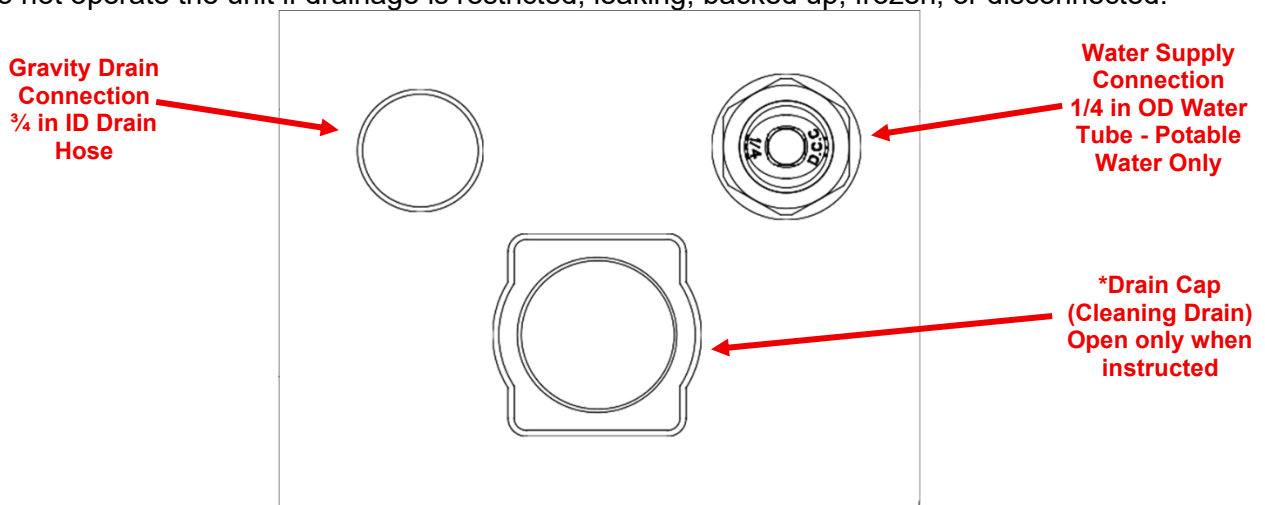

Figure C - Water Supply, Gravity Drain, and Cleaning Drain Connections

***NOTE:** The drain cap is used only for draining remaining water after cleaning or before extended shutdown. Do not loosen or open the drain cap while the unit is operating.

Drain Connection and Leak Check

- Connect the drain tubing securely before operating the unit.
- After drain installation, slowly pour approximately 3.8 L (1 gal) of water into the ice storage bin to verify proper drainage and inspect all drain connections for leaks.
- Tighten leaking fittings or drain connections before placing the unit into service.
- Reinspect drain connections after final positioning and during initial operation.

Important Drainage Information

This unit is not a freezer. Ice stored in the bin will naturally melt over time, especially during normal door opening, high ambient conditions, or periods of low ice usage. A properly functioning drain system is required to remove melted ice water during normal operation.

Restricted drainage, improper drain slope, blocked drain tubing, or poor installation practices may result in standing water, water overflow, unsanitary conditions, increased ice melting, equipment damage, or property damage.

Common Causes of Low Ice Production

Low ice production is most often caused by installation or maintenance conditions, not equipment failure. Before requesting service, check for:

- Front grille or condenser airflow blocked
- Unit installed near fryers, ovens, dishwashers, steam equipment, or direct heat
- Dirty condenser
- Warm incoming water
- High ambient temperature
- Restricted water filter or poor water pressure
- Drain restriction or poor drain slope

INSTALLATION

- Mineral scale buildup or overdue cleaning

Correct these conditions before evaluating ice production capacity.

Final Installation Checks

Before placing the unit into service, complete the following final installation checks.

- All packaging materials, tape, protective film, shipping restraints, and loose materials have been removed from the unit.
- Permanent labels, warning labels, rating label, and serial number label remain in place and readable.
- The unit has been positioned on a stable, level surface and all adjustable feet are securely attached, properly seated, and fully supporting the unit.
- Required rear, top, and side clearances have been confirmed.
- If the unit cannot be pulled forward for cleaning underneath and around the base, the base has been sealed to the floor with an approved caulking compound.
- Front grille and condenser airflow openings are completely unobstructed.
- Electrical supply matches the voltage and frequency shown on the rating label.
- Power cord and plug are undamaged, accessible, and not pinched, crushed, sharply bent, or strained.
- Water supply is connected to a potable cold-water source.
- Water line has been flushed before connection.
- Water pressure and inlet water temperature are within the specified operating range.
- A suitable water pressure regulator is installed if incoming water pressure exceeds 0.55 MPa (80 PSI)
- Included sediment filter is installed in the correct flow direction and checked for leaks.
- Water supply valve is open before startup.
- All water supply connections have been checked for leaks.
- Drain line slopes continuously downward and is not kinked, restricted, submerged, or routed upward.
- Drain line has been tested by pouring approximately 3.8 L (1 gal) of water into the ice storage bin.
- All drain connections have been checked for leaks and tightened as required.
- Ice storage bin and accessible food-contact areas have been cleaned before first use.
- Door opens, closes, and seals properly.
- Ice slideway moves freely and returns to its normal position without obstruction.
- Operators have reviewed the safety, operation, cleaning, and maintenance instructions in this manual.

Do not place the unit into service until all installation checks are complete. Before normal ice use, complete all required cleaning, sanitizing, startup, and initial ice discard procedures described in the **Operation** and **Cleaning** and **Maintenance** sections of this manual.

Installation and Warranty Conditions

Improper installation, incorrect electrical supply, improper water or drain connection, blocked airflow, unstable placement, operation outside specified conditions, inadequate cleaning, unauthorized modification, non-approved parts, or service by unqualified personnel may affect warranty coverage.

OPERATION

Proper operation is essential for safe use, normal ice production, ice quality, sanitation, refrigeration system performance, and long equipment life. Improper operation, blocked airflow, incorrect water conditions, restricted drainage, poor cleaning practices, unsafe ice handling, operation outside recommended conditions, or failure to follow operating instructions may result in electrical shock, refrigerant hazard, water leakage, unsanitary ice, reduced ice production, abnormal operation, equipment damage, or unsafe operating conditions.

Read and understand all operating instructions before using the unit. Operators should become familiar with the controls, indicator lights, normal operating sounds, freeze and harvest cycles, water flow behavior, airflow requirements, cleaning procedures, drainage requirements, and safe ice-handling practices before placing the unit into regular service.

Before First Use



CAUTION!

Do not consume ice produced during initial startup, after cleaning, after sanitizing, after filter replacement, after water-system service, or after extended shutdown until required cleaning, rinsing, flushing, and ice-discard steps have been completed.

- Confirm unit is installed, leveled, and connected according to the installation instructions in this manual.
- Confirm the water supply is turned on and all water and drain connections have been checked for leaks.
- Confirm the drain line is properly connected and draining correctly.
- Confirm the front ventilation grille and condenser airflow areas are unobstructed.
- Clean the ice storage bin and accessible food-contact surfaces before first use.
- Confirm all packaging materials, tape, protective film, and loose materials are removed from the unit.
- Confirm the door closes properly and the ice slideway moves freely.
- If the unit was tilted, laid on its side, or transported non-upright, allow it to remain upright for at least 24 hours before operation.

After startup:

- Discard the first two batches of ice before placing the unit into regular service.
- Additional ice may need to be discarded after cleaning, sanitizing, extended shutdown, or service procedures.

Understanding Ice Machine Operation

NORIOTA undercounter ice machines use an air-cooled refrigeration system with a vertical evaporator and a recirculating water system to produce slab-style cube ice. Understanding normal freeze, harvest, water flow, and storage operation helps operators recognize normal machine behavior, maintain ice quality, and identify abnormal operating conditions before they become larger problems.

Ice production performance is affected by airflow, ambient temperature, incoming water temperature, water quality, drain performance, cleanliness, loading conditions, and operating environment. Production capacity may vary depending on installation conditions and environmental conditions.

Freeze Cycle

During the freeze cycle:

- The compressor, condenser fan motor, and water pump operate simultaneously.
- The water pump continuously circulates water from the water trough across the evaporator surface.
- The evaporator removes heat from the water, causing ice to form gradually on the evaporator grid.
- Water that does not freeze immediately returns to water trough and recirculates through the system.
- Ice thickness gradually increases until the programmed harvest condition is reached.

Freeze cycle duration varies depending on the ambient temperature, incoming water temperature, water quality, airflow conditions, condenser cleanliness, drain performance, installation conditions, and ice thickness setting.

Longer freeze cycles are normal during high ambient temperatures, warm incoming water conditions, restricted airflow conditions, or periods of heavy ice demand.

Harvest Cycle

After the freeze cycle is complete, the control system automatically initiates the harvest cycle. During harvest:

- The hot gas valve changes refrigeration flow conditions to help release the ice slab from evaporator surface.
- The ice slab releases from the evaporator and falls into the cube separation area.

OPERATION

- The slab separates into individual cubes before entering the ice storage bin.
- Water flow and drain activity may change temporarily during harvest operation.
- Clicking, cracking, shifting, or dropping sounds during harvest are normal.

Repeated incomplete harvests, delayed ice release, or irregular cube separation may indicate mineral scale buildup, restricted airflow, dirty condenser surfaces, poor water conditions, improper leveling, or cleaning requirements.

Water Flow and Recirculation

During ice production, water continuously recirculates through the internal water system. Minerals and impurities do not freeze at the same rate as ice and gradually become concentrated in the remaining circulating water during operation.

Proper cleaning, filtration, airflow, drainage, and water conditions are important for maintaining normal ice production and ice quality.

Restricted water flow, unstable water pressure, blocked filtration, drain restrictions, or mineral scale buildup may affect freeze timing, harvest performance, cube formation, and overall ice production.

Automatic Bin-Full Restart

The unit automatically starts and stops ice production based on operating conditions and ice storage level.

When the storage bin reaches the full condition, the unit automatically stops ice production. After ice is removed or melts below a certain level, the unit automatically resumes normal operation.

Environmental and Operating Condition Effects

Ice production capacity, freeze timing, harvest timing, ice quality, and energy usage are affected by installation and operating conditions.

Conditions that may reduce production capacity or affect operation include:

- High ambient temperatures
- Warm incoming water temperatures
- Restricted airflow or blocked ventilation
- Dirty condenser surfaces
- Hard water or mineral scale buildup
- Frequent door opening
- Drain restrictions
- Poor water quality
- Installation near heat-producing equipment

Providing adequate airflow, maintaining clean condenser surfaces, using appropriate filtration, maintaining proper drainage, and following the recommended cleaning schedule help support normal ice production and long equipment life.

Control Panel Overview



NOTICE!

Controller indicator lights may change, flash, or pause during normal startup, freeze, harvest, cleaning, bin-full, and restart operation. Do not assume flashing indicators always indicate a fault. Refer to the **Troubleshooting** section if repeated fault indicators occur or ice production does not resume normally.

The control panel allows the operator to start and stop ice production, monitor operating status, activate cleaning functions, and observe fault conditions. Operators should become familiar with normal indicator behavior and controller operation before placing the unit into regular service.



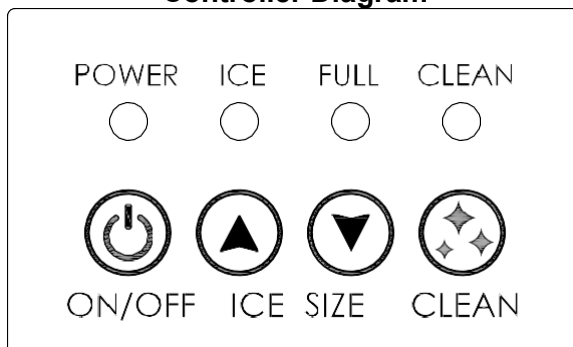

Normal indicator activity, flashing lights, compressor cycling, freeze timing variation, and automatic startup or shutdown behavior may occur during normal operation depending on operating conditions and machine status.

OPERATION

Controller Diagram



Button Functions

FUNCTION	BUTTON	OPERATION
Start ice production	ON/OFF 	Press ON/OFF to start automatic ice making. The ICE indicator illuminates and the unit begins automatic operation after the initial startup check.
Stop ice production	ON/OFF 	Press ON/OFF to place the unit in standby. Ice production stops. The POWER indicator remains on.
Ice size adjustment	ICE SIZE  	Press ▲ or ▼ during ice-making operation to adjust ice thickness from -4 to +4. Positive values increase thickness. Negative values decrease thickness.
Cleaning cycle	CLEAN 	In standby mode, press and hold CLEAN for 3 seconds to start the cleaning program. The cleaning program runs approximately 30 minutes, then returns to standby.

Indicator Lights

Indicator	Normal Operation Meaning
POWER	Solid: Unit has electrical power and is in standby or operating mode.
ICE	Solid: Ice production operation active. Flashing: Harvest cycle or transition between operating stages.
BIN FULL	Solid: Ice storage bin full. Ice production paused automatically. Flashing: Bin no longer full. Counting down to switch to ice production.
CLEAN	Solid: Cleaning cycle active. Flashing: Cleaning reminder.

Startup and Standby Operation

When the unit is connected to power, the POWER indicator illuminates to show the controller is energized. Press **ON/OFF** to begin automatic ice production. During initial startup, all indicators illuminate for approximately 3 minutes while the controller performs a system check and startup sequence. The unit then automatically enters normal ice production operation.

During normal operation, the controller automatically manages:

- Water fill operation
- Freeze cycle timing
- Harvest cycle timing
- Bin-full operation
- Automatic restart operation

Press **ON/OFF** again to place the unit into standby mode. In standby mode:

- Ice production stops
- Refrigeration operation stops
- The POWER indicator remains illuminated
- The unit remains energized unless disconnected from electrical power

The unit may pause briefly between operating stages during normal operation. Temporary pauses, flashing indicators, or delayed restart behavior may occur during startup and normal cycling.

Ice Thickness Adjustment

Ice thickness adjustment allows the operator to slightly increase or decrease freeze cycle duration to compensate for environmental conditions, incoming water temperature, water quality, or normal cube-formation correction.

To adjust the ice thickness, press  UP or  DOWN during ice-making operation to adjust ice thickness from -4 to +4. Positive values increase thickness. Negative values decrease thickness.

Ice thickness adjustment should be used to correct cube formation, not to force extreme ice thickness. Ice that is too thick or too thin may reduce production, affect harvest operation, or cause irregular cube separation.

Do not adjust ice thickness to compensate for dirty condenser surfaces, restricted airflow, low water pressure, poor drainage, blocked filters, or scale buildup. Correct installation, water, airflow, and cleaning issues first.

Increasing the setting increases freeze time and generally produces thicker ice bridges and larger cube formation. Decreasing the setting reduces freeze time and generally produces thinner ice bridges and smaller cube formation.

Small adjustments are recommended. Allow the unit to complete several full ice-making cycles before evaluating further adjustment changes. Do not repeatedly change settings rapidly during operation.

Cleaning Cycle

The **CLEAN** button activates the automatic cleaning program used during cleaning and descaling procedures.

To start the cleaning program:

1. Place the unit in standby mode.
2. Press and hold **CLEAN** for approximately 3 seconds.
3. The **CLEAN** indicator illuminates and the cleaning program begins.
4. The cleaning program runs for approximately 30 minutes, then returns to standby mode.

Cleaning frequency depends on water quality, usage, and operating environment. In hard-water areas, more frequent cleaning and descaling may be required.

If the **CLEAN** indicator flashes as a reminder, perform the full cleaning and descaling procedure. Do not ignore repeated **CLEAN** reminder indications, especially in hard-water or high-use environments.

Do not use the **CLEAN** button as a substitute for the full cleaning procedure. Cleaning chemicals, rinsing, draining, sanitizing, and ice discard steps must be completed as instructed in the **Cleaning and Maintenance** section. Refer to the **Cleaning and Maintenance** section for the full cleaning procedure.

Normal Controller Behavior

During normal operation, the controller automatically changes operating modes based on machine conditions and ice storage level.

The following behaviors may occur during normal operation and do not necessarily indicate a malfunction:

- Indicator lights turning on or flashing during operating transitions
- Temporary pauses between freeze and harvest operation
- Automatic shutdown when the storage bin becomes full and automatic restart after ice level drops
- Variable freeze or harvest timing
- Intermittent fan or compressor operation
- Return to standby mode after electrical power interruption or power outage

Fault Indicator Overview

The controller may flash indicator lights in specific patterns to identify certain abnormal operating conditions. When contacting service, report the flashing indicator pattern exactly as observed, including which indicators are flashing and whether they are flashing alone or together.

Repeated fault indications may result from restricted airflow, water supply problems, drain restrictions, scale buildup, high ambient temperature, dirty condenser surfaces, or electrical or component faults.

OPERATION

Indicator Behavior	General Condition
ICE indicator blinking	Ice production or sensor condition
CLEAN indicator blinking	Cleaning or temperature condition
BIN FULL indicator blinking	Water or storage condition
Multiple indicators blinking	Fault condition detected

If repeated fault indications occur:

- Inspect airflow, water supply, drainage, and cleaning condition
- Refer to the **Troubleshooting** section of this manual
- Stop operation if unsafe conditions are observed
- Contact qualified service personnel if the condition continues

Initial Startup Procedure



Do not start the unit until installation is complete, the unit is level, the water supply is open, the drain has been tested, airflow openings are unobstructed, and all final installation checks have been completed. Improper startup may result in water leakage, abnormal operation, reduced ice production, or equipment damage.

Follow this procedure when starting the unit after installation, cleaning, sanitizing, filter replacement, extended shutdown, relocation, or an extended period without operation.

Do not start the unit until installation has been completed, the unit is level, the water supply is connected and turned on, the drain has been tested, airflow openings are unobstructed, and the startup inspection has been completed.

Startup Sequence

1. Confirm the unit has remained upright for the required compressor settling time before connecting power.
2. Confirm the unit is level, stable, and positioned with required clearances.
3. Confirm the front grille and condenser airflow openings are unobstructed.
4. Confirm the water supply, drain line, and included sediment filter are connected and checked for leaks.
5. Turn on the water supply.
6. Plug the unit into a properly grounded electrical outlet matching the rating label.
7. If the unit was recently unplugged or power was interrupted, wait at least 10 minutes before restarting.
8. Press **ON/OFF** to begin automatic ice production.
 - i. If electrical power is interrupted, the unit will enter standby mode when power is restored. Press **ON/OFF** again to resume ice production.
9. The water inlet valve will energize immediately to fill the reservoir.
10. After approximately 3 minutes, the compressor and water pump will begin the ice-making cycle. Ambient temperature, incoming water temperature, water pressure, airflow, and installation conditions may affect startup timing.
11. The first harvest should occur within approximately 60 minutes under normal conditions.
12. Discard the first two batches of ice.

Do not repeatedly cycle power rapidly during startup or operation.

Water Fill and First Freeze Cycle

After startup, the water inlet valve energizes immediately to fill the reservoir. After approximately 3 minutes, the compressor and water pump begin the ice-making cycle.

During the first operating cycle:

- Water circulation sounds are normal.
- Fan and compressor operation may begin after a short delay.
- Water may move through the drain during certain operating stages.
- Freeze timing may be longer than later cycles while the unit stabilizes.
- Ice formation may appear uneven during the first cycle.

Do not interrupt the first operating cycle unless water leakage, abnormal noise, electrical odor, repeated fault indicators, or other unsafe conditions are observed.

First Harvest and Ice Discard

When the first ice slab releases from the evaporator, ice may drop suddenly into the storage bin. Cracking, shifting, or ice-dropping sounds during harvest are normal.

Discard the first two batches of ice after initial startup. Discard additional batches if unusual odor, taste,

discoloration, debris, cleaning residue, or abnormal ice appearance is observed. Do not consume or use startup ice that has not been discarded.

The first batch may not represent normal stabilized production. Allow the unit to complete several full freeze and harvest cycles before evaluating ice thickness, ice quality, or production performance.

Automatic Bin-Full Operation

When the ice storage bin reaches the full condition, the unit automatically stops ice production. After ice is removed or melts below the full condition, the unit automatically resumes normal operation. Automatic stopping and restarting during normal operation is expected behavior and does not indicate a malfunction.

Abnormal Startup Conditions

Stop operation and disconnect power if any of the following occur:

- Water leakage
- Restricted or backed-up drainage
- Refrigerant odor or suspected refrigerant leak
- Repeated fault alarms
- Loud abnormal mechanical noise
- Smoke, sparking, overheating, or burning odor
- No water circulation during freeze operation
- Repeated incomplete harvest cycles
- Continuous overflow or abnormal water flow

Correct installation or operating problems before returning the unit to service.

Initial Startup Expectations and Stabilization Period

During initial startup and the first several operating cycles:

- Freeze and harvest timing may vary while the unit stabilizes
- Initial production capacity may be lower temporarily
- Water flow and drain sounds are normal
- Clicking, cracking, fan, compressor, or ice-dropping sounds are normal
- Small amounts of condensation or moisture near the bin opening may occur
- Slight variation in cube appearance during initial operation may be normal

Ice production capacity, freeze timing, and harvest timing are affected by ambient temperature, water temperature, airflow, water quality, condenser cleanliness, and installation conditions.

Ice production capacity is not usually evaluated during the first few cycles. Startup production may vary while the unit stabilizes and the water system clears air from the lines. For best results, allow the unit to operate through several complete cycles under normal conditions before making ice thickness adjustments or evaluating production performance.

If abnormal noise, water leakage, repeated fault indicators, poor drainage, restricted airflow, or abnormal operating conditions are observed, stop operation and correct the condition before continued use.

Bin Full Operation



NOTICE!

The ice slideway must move freely for normal bin-full operation. Do not force, block, bend, remove, or hold the ice slideway open. Obstruction of the ice slideway may cause false bin-full indications or prevent normal ice production.

The unit automatically monitors the ice storage bin and pauses ice production when the bin reaches the full condition.

A ice slideway is positioned below the evaporator in the ice drop area. During harvest, ice releases from the evaporator, contacts the ice slideway, and falls into the storage bin. After the ice passes, the ice slideway should return freely to its normal position.

If the storage bin becomes full, accumulated ice prevents the ice slideway from returning to its normal position. The controller interprets the sustained open position as a bin full condition and automatically pauses ice production.

When enough ice is removed and the ice slideway returns to its normal position, ice production resumes automatically. This is normal operation and does not indicate a fault.

OPERATION

- Do not force, block, bend, remove, or hold the ice slideway open.
- Ensure the ice slideway moves freely at all times.
- Keep ice from being packed tightly against the ice slideway area.
- Inspect the ice slideway regularly for free movement and cleanliness.

Improper handling or obstruction of the ice slideway may interfere with normal ice production or bin full detection.

Power Interruption and Restart Behavior

The unit will stop ice production during electrical power interruption, power outage, unplugging, circuit interruption, or electrical service conditions. After power is restored:

- The control panel should illuminate and function normally.
- The unit will automatically return to standby mode.
- Press the ON/OFF button to restart ice production.
- Freeze timing and harvest timing may vary temporarily during restart.
- The first harvest cycle after restart may take longer than normal.

Important Power Interruption Information

- Allow several minutes before reconnecting power after unplugging the unit to help protect the refrigeration system from short cycling.
- Repeated rapid power cycling may damage refrigeration components or affect normal operation.
- After prolonged power interruption, inspect the storage bin and discard melted or potentially contaminated ice as necessary.
- If fault indicators, abnormal noise, restricted drainage, or abnormal operation occur after power restoration, stop operation and inspect the unit before continued use.
- If the unit does not resume normal operation after power is restored, contact qualified service personnel.

Ice Removal and Ice Handling



CAUTION!

Ice is a food-contact product. Improper ice handling, contaminated scoops, foreign objects in the storage bin, or unsanitary storage conditions may result in unsafe ice or contamination.

Use the provided ice scoop or another clean food-grade scoop when removing ice from the storage bin. Do not remove ice with bare hands, glassware, cups, or containers that may break or contaminate the ice.

Ice Scoop Storage

Store the ice scoop on the scoop holder located on the interior side wall of the ice storage bin.

- Place the scoop back on the holder after each use.
- Do not leave the scoop loose in the ice for extended periods.
- Do not place the scoop on dirty surfaces, counters, packaging, or equipment tops.
- Clean and sanitize the scoop regularly according to site sanitation procedures.
- If the scoop becomes dirty, dropped, or contaminated, clean and sanitize it before returning it to the holder or using it to remove ice.

Preventing Ice Contamination

Discard ice immediately if contamination is suspected. Do not use ice if:

- Foreign material, debris, or unusual residue is present
- Unusual odor or taste is observed
- Water contamination is suspected
- Cleaning chemicals or sanitizer residue may be present
- The unit has not been cleaned after extended shutdown or service

Discard the first two batches of ice after cleaning, sanitizing, filter replacement, water-system service, or extended shutdown.

If the unit is used infrequently, empty the ice storage bin periodically and allow the unit to produce fresh ice.

Normal Sounds and Operating Characteristics

Commercial ice machines produce a variety of sounds, temperature changes, water movement, and automatic operating behaviors during normal operation. Many sounds and operating conditions that may seem unusual are expected during normal freeze, harvest, drainage, filling, and refrigeration operation. The following conditions are generally considered normal:

- Water flowing, splashing, or circulating inside the unit.
- Swooshing or flowing sound when water valve opens to fill the water trough for each cycle
- Ice dropping into the storage bin during harvest, which may produce a louder sound when bin is empty

OPERATION

- Clicking sounds from relays, valves, or controller operation
- Compressor startup and shutdown sounds as well as pulsating or humming during operation
- Condenser fan motor airflow noise
- Refrigerant flow sounds, including hissing, rattling, or bubbling sounds or gurgling at end of cycle
- Hard surfaces such as walls, floors, counters, and cabinetry may make normal operating sounds seem louder.
- Warm air discharge from the front ventilation grille.
- Temporary pauses between freeze, harvest, restart, and bin-full operation.
- Ice production stopping automatically when the storage bin is full.
- Ice production restarting automatically after enough ice is removed or melts.
- Unit returning to standby mode after electrical power interruption or power outage, requiring pressing **ON/OFF**  to resume ice production.
- Newly produced ice may appear wet, and ice surfaces may develop light frost when placed in liquid.
- Ice gradually melting in the storage bin during normal operation.
- Water draining from the storage bin as stored ice melts.
- Variation in freeze time, harvest time, ice appearance, or production rate depending on ambient temperature, water temperature, airflow, water quality, and cleaning condition.
- The first harvest after startup may take longer than later cycles.

The unit uses automatic freeze, harvest, and bin-full controls rather than fixed-cycle operation. Operating conditions may fluctuate as the unit responds to water temperature, ambient temperature, ice demand, airflow, drain condition, and selected ice thickness setting.

Shutdown Procedure



NOTICE!

Do not shut off the water supply or disconnect power during normal ice production unless shutdown is required. If the unit is stopped during harvest, allow the ice to release completely before restarting whenever practical.

Follow these procedures when stopping ice production for overnight shutdown, cleaning, maintenance, extended inactivity, or service preparation.

Normal Shutdown Procedure

To stop ice production:

1. Press **ON/OFF** to place the unit in standby mode.
2. Confirm ice production stops and the POWER indicator remains illuminated.
3. Leave the storage bin door slightly open if the unit will remain off for an extended period to help reduce odor and moisture buildup.

The unit remains energized while connected to power. To fully disconnect electrical power, unplug the power cord from the electrical outlet.

Short-Term Shutdown

For short periods without ice production:

- The unit may remain operating normally.
- The unit may also be placed in standby mode if ice production is not required.
- Do not shut off the water supply while the unit is operating.

Ice stored in the bin gradually melts during normal storage conditions. Meltwater drains automatically through the drain system.

Shutdown for Cleaning or Service

Before cleaning, maintenance, inspection, or service:

1. Press **ON/OFF** to place the unit in standby mode.
2. Disconnect the power cord from the electrical outlet.
3. Shut off the water supply if required by the cleaning or service procedure.
4. Drain water from system only as instructed in the cleaning, draining, or extended shutdown procedure.

Allow moving components, electrical components, and refrigeration components to stop completely before beginning cleaning or service procedures. Refer to the **Cleaning and Maintenance** section for full cleaning, draining, sanitizing, and restart procedures.

Extended Shutdown and Storage



WARNING!

Always disconnect power at the source before inspection, cleaning, draining, maintenance, service, or removal from service. Failure to disconnect power may result in electrical shock, serious injury, or death.

Proper shutdown, draining, cleaning, and drying are important before extended non-use, storage, relocation, transport, freezing conditions, or seasonal shutdown. Water left inside the unit may result in odor, scale buildup, biological growth, freezing damage, water leakage, component damage, or unsafe operating conditions.

Extended Shutdown Procedure

1. Press **ON/OFF** to place the unit in standby mode.
2. Disconnect the power cord from the electrical outlet. Always grasp the plug firmly and pull straight out. Do not unplug the unit by pulling on the power cord.
3. Shut off the water supply at the main water supply or shutoff valve.
4. Disconnect the water supply line from the water inlet connection.
5. Remove all remaining ice from the storage bin.
6. Unscrew the drain cap at the rear of the unit and drain remaining water into a suitable container or drain location.
7. Reinstall and tighten the drain cap after water has fully drained.
8. Clean and dry accessible interior surfaces as instructed in the **Cleaning and Maintenance** section.
9. Leave the door propped open to allow air circulation and help reduce odor, mold, and mildew.
10. Leave the water supply line disconnected and the power cord unplugged until the unit is ready to be recommissioned.
11. If the unit will be moved, transported, or stored after draining, disconnect and drain the external drain tubing whenever practical. Allow drain tubing and water lines to dry before storage to help reduce trapped water, leakage, odor, mold, or freezing damage.
12. Store the unit upright in a clean, dry, well-ventilated location ideally protected from freezing temperatures, weather exposure, pests, and physical damage.

Important Extended Shutdown Information

13. Do not leave water inside the unit during freezing conditions or long-term storage.
14. After extended shutdown, perform cleaning and sanitizing procedures before returning the unit to service.
15. Discard the first two batches of ice after recommissioning.
16. If the unit was tilted, transported on its side, or moved in a non-upright position, allow the unit to remain upright and disconnected from power for at least 24 hours before startup.

Freeze Protection and Cold Weather Storage



NOTICE!

Do not winterize this unit with antifreeze of any type. Antifreeze may damage internal ice-making surfaces, create a potential health hazard, and affect warranty coverage.

Do not allow water to remain inside the unit during freezing conditions. Freezing temperatures may damage water lines, pumps, valves, drain components, and other internal water-system components. If the unit will be exposed to freezing temperatures, placed in unheated storage, transported during cold weather, or shut down seasonally:

- Follow the **Extended Shutdown** Procedure in this manual, including the complete draining procedure.
- Ensure water supply line is disconnected and fully dried before storage.
- Ensure internal components, internal drain lines, and external drain line is fully dried before storage.
- Do not use antifreeze of any type inside the unit.
- Store the unit upright in a clean, dry, well-ventilated location protected from freezing temperatures whenever possible.

Before returning the unit to service after cold-weather storage, inspect the unit carefully, reconnect the water supply and drain, check for leaks, clean and sanitize the unit, and discard the first two batches of ice. Damage caused by freezing conditions, improper draining, or improper storage is not considered a manufacturing defect.

Restarting After Extended Shutdown

After extended shutdown, storage, transport, seasonal closure, cleaning, or freezing-condition protection, the unit must be inspected, cleaned, and recommissioned before returning to normal operation.

Before Restarting:

- Confirm the unit remains upright and stable.
- Confirm all drain components, drain tubing, and water connections are properly installed and tightened.
- Confirm the drain nut inside the ice storage bin is properly reinstalled and tightened.
- Confirm the water supply tubing and drain tubing are not kinked, restricted, damaged, or leaking.
- Confirm the front ventilation grille and airflow openings are clean and unobstructed.
- Confirm the power cord and plug are undamaged.
- Confirm the storage bin and accessible food-contact surfaces have been cleaned and sanitized.
- Confirm the storage bin drain is functioning normally.
- Confirm all panels, guards, and removable components are properly installed.

Restart Procedure:

1. Inspect the unit for dirt, debris, moisture, damage, insects, rodents, nesting material, or other foreign material.
2. Clean the unit after long-term storage by following the **Cleaning and Maintenance** section.
3. Place the unit in its final operating position.
4. If the unit was tilted, transported on its side, or moved in a non-upright position, allow the unit to remain upright and disconnected from power for at least 24 hours before startup.
5. Connect the drain tubing and confirm proper gravity drainage.
6. Connect the water supply tubing.
7. Open the water supply valve and inspect all fittings and tubing for leaks.
8. Plug the power cord into a properly grounded electrical outlet.
9. Press the **ON/OFF** button to begin normal ice production.
10. After the water trough has filled with water, inspect the drain nut connection for leaks.
11. Allow the unit to complete several normal freeze and harvest cycles.
12. Discard the first two batches of ice before normal use.

Important Restart Information

- Initial freeze timing and harvest timing may vary temporarily during restart.
- Newly produced ice may appear wet during initial operation.
- If abnormal noise, restricted drainage, water leakage, fault indicators, poor airflow, or abnormal operation is observed, stop operation and correct the condition before continued use.
- If the unit does not return to normal operation after recommissioning, contact qualified service personnel.

CLEANING AND MAINTENANCE

Proper cleaning, descaling, sanitizing, inspection, and preventive maintenance are essential for ice quality, sanitation, refrigeration-system performance, production capacity, energy efficiency, and long equipment life. Failure to maintain the unit properly may result in mineral scale buildup, unsanitary ice conditions, restricted airflow, water leakage, poor ice production, abnormal operation, corrosion, equipment damage, or unsafe operating conditions.

Cleaning and Maintenance Safety



WARNING!

Failure to disconnect power, shut off water supply, follow proper cleaning procedures, or use appropriate cleaning chemicals may result in electrical shock, refrigerant hazard, contamination, water leakage, equipment damage, serious injury, or unsafe operating conditions.



CAUTION!

Improper cleaning methods, mineral scale buildup, blocked airflow, drain restrictions, water intrusion into electrical areas, or use of non-approved chemicals may reduce ice production, contaminate ice, damage components, or create unsafe operating conditions.

- Press **ON/OFF** to place the unit in standby mode, disconnect the power cord, and shut off the water supply when required before cleaning, inspection, maintenance, movement, or service.
- Always grasp the plug firmly when disconnecting power. Do not pull on the power cord.
- Do not clean the unit while energized or while moving components remain in operation.
- Do not immerse the unit, power cord, plug, or electrical components in water or any other liquid.
- Do not spray, hose down, pressure clean, or steam clean the unit.
- Do not allow water, cleaning chemicals, scale remover, sanitizer, food residue, or debris to enter electrical areas, controls, airflow openings, fan areas, or refrigeration components.
- Use caution when cleaning around evaporator surfaces, ice slideway areas, drain openings, sheet-metal edges, and condenser.
- Sheet metal edges may be sharp. Avoid direct contact.
- Keep the area around the unit clean and dry during maintenance procedures to reduce slip hazards.
- Dry all cleaned surfaces completely before reconnecting power or returning the unit to service.
- Do not store bottles, cans, food, tools, packaging, or any non-ice items in the ice storage bin. Foreign objects may contaminate ice, damage surfaces, or block the drain.
- If the unit has been exposed to flooding, excessive water intrusion, refrigerant-line damage, or electrical damage, discontinue use and contact qualified service personnel before reconnecting power.
- Internal electrical service, sealed refrigeration-system service, controller service, pump replacement, wiring repair, and refrigeration repairs must be performed by qualified service personnel only.

Cleaning, Descaling, and Sanitizing Overview



WARNING!

Disconnect power before removing panels, cleaning electrical areas, or performing maintenance beyond normal operator cleaning procedures.



CAUTION!

Ice machine cleaner contains acid. Wear appropriate hand and eye protection when handling cleaning chemicals. Do not mix ice machine cleaner with sanitizer or other chemicals.

Ice machine maintenance includes three related but different tasks: cleaning, descaling, and sanitizing. Cleaning removes visible soil, residue, slime, and debris from the storage bin, scoop, drain areas, exterior surfaces, and accessible components. Descaling removes mineral deposits that build up inside the water system, water trough, evaporator, and water distribution areas as water freezes. Sanitizing reduces bacteria, mold, yeast, and other microorganisms on food-contact and ice-contact surfaces after cleaning has removed soil and scale.

These tasks are not interchangeable. Descaling does not sanitize the unit, and sanitizing does not remove mineral scale. Descale the ice-making water system when mineral deposits are visible, ice formation becomes irregular, harvest performance declines, production slows, the **CLEAN** reminder appears, or hard-water conditions require it. Sanitize the storage bin and ice-contact surfaces after descaling, after extended shutdown, after service, when contamination is suspected, or whenever site sanitation procedures require it. Clean exterior surfaces, the ice scoop, storage bin, drain areas, and condenser surfaces on a regular schedule based on use, environment, and water quality.

CLEANING AND MAINTENANCE

Do not use or consume any ice produced during cleaning, descaling, or sanitizing procedure, or the first two batches after returning the unit to service.

Descaling the Water System



CAUTION!

Use only commercial ice machine cleaner suitable for nickel-safe evaporator systems. Improper cleaning chemicals may damage internal ice-making surfaces or components.

Mineral scale forms inside the water system during normal ice production. Regular descaling helps remove mineral deposits from the water trough, evaporator, water distribution system, and related ice-making surfaces. Descaling frequency depends on water hardness, filtration effectiveness, usage, and operating conditions. In hard-water conditions, including water hardness around 15 to 20 grains per gallon, descaling may be required as often as every 3 months.

Before Descaling

1. If the unit is making ice, allow the current cycle to finish or initiate harvest.
2. Press the **ON/OFF** button to place the unit in standby mode.
3. Remove all ice from the storage bin.
4. Keep the unit connected to the water supply.
5. Confirm the drain system is connected and draining properly.

Descaling Procedure

1. Pour 237 mL (8 oz) of nickel-safe ice machine cleaner into the water trough.
 - i. Use only ice machine cleaner specifically labeled for nickel-safe ice machine use.
 - ii. Use 237 mL (8 oz) of nickel-safe ice machine cleaner unless the cleaner manufacturer's instructions require a lower concentration for this application.
2. Press and hold the **CLEAN** button for approximately 3 seconds.
3. Confirm the **CLEAN** indicator illuminates.
4. Allow the automatic cleaning cycle to run for approximately 30 minutes.
5. When the cleaning cycle is complete, the unit will return to standby mode.
6. Locate the drain cap on the rear of the unit, near the water and drain connection.
7. Carefully unscrew and remove the drain nut.
8. Drain wastewater into a suitable container or drain location.
9. Reinstall and tighten the drain cap after draining is complete.



CAUTION!

Do not loosen or remove the drain cap while the unit is operating.

Heavy Scale Note: If heavy mineral scale remains after the descaling cycle, repeat the descaling procedure once using fresh nickel-safe ice machine cleaner before beginning the rinse procedure. Do not add cleaner during rinse cycles. If heavy scale remains after a second descaling cycle, discontinue operation and contact qualified service personnel.

Rinse Procedure

Rinsing is required to remove cleaner residue from the ice-making water system.

1. Do not add ice machine cleaner during rinse cycles.
2. Press and hold the **CLEAN** button for approximately 3 seconds.
3. Confirm the **CLEAN** indicator illuminates.
4. Allow the clean-water rinse cycle to run for approximately 30 minutes.
5. When the cleaning cycle is complete, the unit will return to standby mode.
6. Drain the rinse water using the rear drain cap.
7. Reinstall and tighten the drain cap after draining is complete.
8. Repeat this clean-water rinse cycle two more times, for a total of three rinse cycles.
9. Reinstall and tighten the drain cap after the final rinse.

After Descaling and Rinsing

1. Confirm the drain nut is reinstalled and tightened securely.
2. Confirm the drain system is connected and draining properly.
3. Return the unit to ice-making operation by pressing the **ON/OFF** button.
4. Discard the first two batches of ice after descaling.

Do not leave cleaner residue inside the water system or ice storage bin.

Sanitizing the Ice Machine and Bin



CAUTION!

Improper chemical handling, mixing incompatible chemicals, excessive sanitizer concentration, or failure to follow chemical manufacturer instructions may result in toxic fumes, contamination, equipment damage, chemical injury, or unsafe operating conditions.



CAUTION!

Never mix sanitizer or sanitizing solution with ice machine cleaner, descaling chemicals, acids, chlorine products, or other cleaning chemicals.

Sanitizing helps reduce bacteria, slime, mold, yeast, and other contamination that may develop inside the ice storage bin, water-contact surfaces, and ice-making system during normal operation. Sanitizing does not remove mineral scale and is not a substitute for descaling.

Sanitize the unit after descaling procedures, after extended shutdown or storage, after service or repair affecting food-contact areas, if contamination is suspected, whenever sanitation conditions require additional cleaning, and as part of regular preventive maintenance.

Use only sanitizer products suitable for commercial ice machine food-contact surfaces. Follow the sanitizer manufacturer instructions for mixing concentration, handling precautions, and required contact time. Avoid direct contact with eyes, skin, and clothing.

Before Sanitizing

1. Press **ON/OFF** button to place the unit in standby mode.
2. Remove all ice from the storage bin.
3. Confirm the descaling and rinse procedure has been completed if mineral scale was present.
4. Keep the unit connected to the water supply.
5. Confirm the drain system is connected and draining properly.

Sanitizing Procedure

1. Prepare sanitizer solution according to the sanitizer manufacturer instructions.
 - i. A sanitizing solution using 30 mL (1 oz) household bleach mixed with 7.5 L (2 gal) warm water at 35 °C to 46 °C (95 °F to 115 °F) may be used, provided all safety precautions and instructions are followed.
 - ii. Use the sanitizing solution only as instructed, and rinse thoroughly after sanitizing. Do not mix bleach sanitizer with ice machine cleaner, descaling chemicals, acids, or any other cleaner.
2. Apply sanitizer solution using a clean cloth, sponge, or spray bottle to:
 - i. Ice storage bin interior
 - ii. Ice slideway area
 - iii. Water trough
 - iv. Evaporator area
 - v. Ice slideway
 - vi. Accessible food-contact surfaces
 - vii. Removable cleaned components
3. Allow sanitizer to remain on surfaces for the sanitizer manufacturer recommended contact time, or at least 3 minutes.
4. Wipe heavily soiled areas as necessary using a clean soft cloth or sponge.
5. Rinse only if required by the sanitizer manufacturer instructions.
6. Inspect the drain area and confirm sanitizer solution drains normally from the storage bin.

Sanitizing the Water Circulation System

NOTE: Drain inspection and cleaning are recommended during sanitizing procedures while the ice storage bin is empty and internal water-contact areas are already accessible. Use the same sanitizer solution prepared for sanitizing the ice storage bin and accessible food-contact surfaces.

1. Confirm the unit is in standby mode.
2. Confirm all descaling cleaner has been drained and all required rinse cycles have been completed if sanitizing following descaling.
3. Locate the drain cap on the rear of the unit, near the water and drain connection.
4. Carefully remove the drain cap and allow remaining water to drain completely into a suitable container or drain location.
5. Reinstall and tighten the drain cap securely.
6. Manually fill the water trough with enough prepared sanitizer solution to reach the normal operating water

CLEANING AND MAINTENANCE

level in the trough. Do not overfill.

7. Press and hold the **CLEAN** button for approximately 3 seconds.
8. Confirm the **CLEAN** indicator illuminates.
9. Allow cleaning cycle to circulate sanitizer solution through water system for approximately 30 minutes.
10. When the cycle is complete, the unit will return to standby mode.
11. Remove the drain cap and drain the sanitizer solution completely.
12. Reinstall and tighten the drain cap securely.
13. Perform a clean-water rinse cycle if required by the sanitizer manufacturer instructions.
14. Discard the first two batches of ice before normal use.

Important: Do not add sanitizer until all descaling cleaner has been drained and the required rinse cycles are complete. Never mix sanitizer with ice machine cleaner, descaling chemicals, acids, or other cleaning chemicals.

Returning the Unit to Service

1. Confirm the drain cap is properly tightened.
2. Confirm all components, panels, and removable parts are properly installed.
3. Confirm the water supply is turned on.
4. Press the **ON/OFF** button to resume ice production.
5. After the water trough has filled with water, inspect the drain cap connection for leaks.
6. Allow the unit to complete several normal freeze and harvest cycles.
7. Discard the first two batches of ice after sanitizing before normal use.

Important Sanitizing Information

- Do not mix sanitizer with ice machine cleaner or other chemicals.
- Do not use abrasive pads, steel wool, wire brushes, or highly corrosive chemicals.
- Do not leave excessive sanitizer residue inside the unit.
- Ice produced during sanitizing or rinse procedures must be discarded.
- More frequent sanitizing may be required in high-use or high-temperature environments.

Condenser Cleaning

A dirty or blocked condenser reduces airflow, lowers ice production, increases operating temperature, increases energy usage, and may shorten component life. Inspect the condenser regularly and clean it whenever dust, lint, grease, or debris is visible.

The condenser should be cleaned at least every 6 months, or more often in dusty, greasy, high-temperature, or high-use environments.



WARNING!

Disconnect power before removing the front panel or cleaning the condenser area. Failure to disconnect power may result in electrical shock, injury, or equipment damage.



CAUTION!

Condenser tubes can be damaged easily. Use caution when cleaning around the condenser. Do not use sharp tools, high-pressure compressed air, liquid cleaners, or excessive force.

Condenser Cleaning Procedure

1. Press **ON/OFF** to place the unit in standby mode.
2. Disconnect the power cord from the electrical outlet.
3. Remove the front panel screws.
4. Carefully lift and pull down the front panel.



NOTICE!

Do not overextend, twist, pull sharply, or allow the front panel to hang by the control wiring. Electrical leads connected to the control panel may be damaged if excessive force is applied.

6. Locate the condenser coil behind the grille.
7. Using a vacuum cleaner with a soft brush attachment, gently remove dust, lint, grease, flour, and debris from condenser coil surface, front grille area, and surrounding compartment.
8. Inspect the condenser for damage, bending, heavy buildup, or blockage.
9. Reinstall the front panel securely.
10. Connect the power cord to the electrical outlet to restore power to the unit.

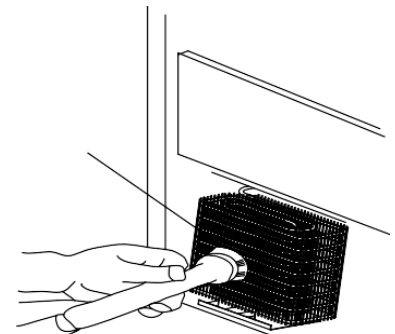

Figure D. Condenser Cleaning Using Vacuum with Soft Brush Attachment

After Cleaning

After condenser cleaning, verify:

- The front grille is unobstructed.
- Rear, top, and side clearances remain intact.
- No wiring was pulled, pinched, loosened, or disturbed.
- The front panel is securely reinstalled.
- The unit restarts and operates normally.

If condenser is badly damaged, heavily clogged with grease, or cannot be cleaned with normal operator-level cleaning, contact qualified service personnel.

Drain System Inspection and Cleaning

Restricted drainage may cause water backup, slow drainage, leakage, odor, slime buildup, sanitation concerns, abnormal operation, or ice production problems. Inspect the drain system regularly to maintain proper drainage and sanitation.

NOTE: Drain inspection and cleaning are best performed during cleaning and sanitizing, when the ice storage bin is empty and drain areas are already exposed for inspection.



WARNING!

Disconnect power before inspecting or cleaning drain components near electrical areas. Water near energized electrical components may create electrical shock hazards.

Drain Inspection Procedure

1. Press **ON/OFF** to place the unit in standby mode.
2. Inspect the drain hose and drain connection areas for kinks, pinched sections, standing water, leaks, loose fittings, slime buildup, or restricted flow.
3. Confirm the drain hose maintains continuous downward slope.
4. Confirm the drain hose is not routed upward, looped above the storage bin floor, kinked, submerged, or restricted.
5. Inspect the drain termination area for blockage, poor air gap, restricted drainage, or standing water.
6. Pour clean water into the storage bin and confirm water drains freely through the bin drain and external drain hose.

If drainage is slow, restricted, or backing up, clean the drain system before returning the unit to service.

Drain Cleaning Guidelines

- Flush the drain system with clean warm water as required.
- Remove visible slime, debris, or buildup from storage bin drain area and accessible drain hose areas.
- Clean surrounding drain areas regularly to reduce odor and contamination.
- Confirm the drain hose remains securely connected after cleaning.
- Confirm the drain termination remains open, unrestricted, and code-compliant.

Do not use excessive force, sharp tools, compressed air, or aggressive drain-cleaning chemicals inside the unit drain system.

After Drain Inspection or Cleaning

After inspection or cleaning, verify:

- Drain water flows freely without backup.
- No leakage is present at drain connections.
- The drain hose remains properly sloped.
- The drain hose is not kinked, pinched, submerged, or routed upward.
- The drain cap is tightened securely.
- The unit returns to normal operation without abnormal drainage behavior.

If drainage problems continue after normal cleaning and inspection procedures, contact qualified service personnel.

Exterior Cleaning

Regular exterior cleaning helps maintain appearance, sanitation, corrosion resistance, and long-term durability. Clean exterior surfaces whenever residue, fingerprints, dust, grease, water spots, or spills are visible.



WARNING!

Disconnect power before cleaning. Do not spray, hose down, pressure clean, or steam clean the unit, control panel, power cord, plug, grille, or electrical areas.

Exterior Cleaning Procedure

1. Press **ON/OFF** to place the unit in standby mode.
2. Disconnect the power cord from the electrical outlet.
3. Prepare a mild detergent solution using approximately 30 mL (1 oz) mild dishwashing liquid mixed with 7.5 L (2 gal) warm water.
4. Wipe exterior surfaces using a soft cloth or sponge with warm water and mild detergent solution.
5. Clean around the door, handle, control panel, grille, and front panel carefully without allowing water into openings or electrical areas.
6. Wipe cleaned surfaces with a clean damp cloth to remove detergent residue.
7. Dry all surfaces thoroughly with a soft clean towel.

Stainless Steel Care

Regular stainless steel maintenance helps reduce the risk of surface staining, tea staining, cosmetic rusting, pitting, water spotting, and mineral residue buildup. Failure to properly maintain stainless surfaces may result in cosmetic discoloration, staining, or corrosion that is not related to a manufacturing defect.

Clean stainless steel surfaces at least once per week, or more frequently in high-traffic, high-grease, high-humidity, coastal, or chemically aggressive environments.

- Use a soft cloth or non-abrasive sponge.
- Wipe in the direction of the stainless steel grain whenever possible.
- Use mild detergent and warm water for routine cleaning.
- Rinse thoroughly with clean water after cleaning.
- Dry completely with a soft clean cloth to prevent water spotting and mineral residue.
- Remove hard water deposits, food acids, salt deposits, sanitizer residue, and cleaning chemical residue promptly.

Do not use steel wool, wire brushes, abrasive pads, metal scrapers, harsh chemicals, or cleaners not suitable for stainless steel. Do not use chlorine-based cleaners on exterior stainless steel surfaces.

Chlorine and Chemical Exposure

Stainless steel exposed to chlorinated environments, including areas near spas, swimming pools, or facilities using chlorine-based sanitizers, may develop discoloration over time. This is a cosmetic condition caused by chemical exposure and does not indicate a material defect. If chlorine-based cleaners or sanitizer residue contact stainless surfaces:

1. Rinse immediately with clean water.
2. Wipe dry thoroughly with a soft clean cloth.

Extended exposure to chlorides may accelerate surface discoloration, tea staining, cosmetic rusting, or pitting.

Environmental Considerations

High humidity, salt air, chemical vapors, hard water deposits, food acids, inadequate cleaning, and poor ventilation can affect stainless appearance and corrosion resistance. Units installed in coastal regions, high-humidity environments, pool or spa facilities, or chemically aggressive environments may require more frequent cleaning and inspection.

Preventive Maintenance and Service Boundary

Operators may perform only the cleaning, descaling, sanitizing, condenser vacuuming, drain inspection, filter replacement, visual inspection, and basic checks described in this manual.

Internal electrical repair, controller service, pump service, fan service, valve service, sensor service, wiring repair, sealed refrigeration-system service, refrigerant handling, compressor service, hot gas valve service, and internal disassembly must be performed only by qualified service personnel.

Improper servicing, unauthorized repair, or modification may result in electrical shock, fire hazard, refrigerant hazard, water leakage, contamination, equipment damage, unsafe operation, or affected warranty coverage.

Water Distribution Tube Cleaning

The water distribution tube delivers water evenly across the evaporator during ice production. If the distribution holes become partially restricted by mineral scale or debris, water may not flow evenly across the evaporator and ice production may become abnormal.

This procedure is intended for advanced maintenance. It may be performed by trained personnel familiar with safe shutdown, panel removal, internal water-system components, and proper reassembly. If the operator is not comfortable removing panels or accessing internal components, contact qualified service personnel.

CLEANING AND MAINTENANCE

Indicators of restricted water distribution may include:

- Incomplete ice cubes
- Misshaped or irregular cubes
- Uneven cube thickness
- Reduced ice production
- Uneven water flow across the evaporator

Before inspecting or cleaning the water distribution tube, confirm:

- Water supply pressure is within the specified operating range.
- The water supply line is not kinked or restricted.
- The sediment filter is not excessively restricted or contaminated.
- The unit has first completed normal cleaning and descaling procedures.



CAUTION!

Disconnect power before removing panels or accessing internal components. Do not perform this procedure while the unit is operating. Do not operate the unit with panels removed.



NOTICE!

Do not enlarge spray holes, damage the distribution tube, disturb wiring, or force components during removal or reinstallation.

Basic Cleaning Procedure

1. Press **ON/OFF** to place the unit in standby mode.
2. Disconnect the power cord from the electrical outlet and shut off the water supply.
3. Locate the water distribution tube.
4. Note the original position of the water distribution tube and spray holes before moving the tube. The spray holes must be returned to the same operating position after cleaning.
5. Carefully rotate the tube forward so the spray holes face outward and are accessible from the front.
6. Clear individual spray holes using a toothpick or similar non-metallic tool.
7. Do not enlarge, deform, or damage the spray holes.
8. After cleaning, rotate the water distribution tube back to its original operating position. Confirm the spray holes face the correct direction for normal water distribution across the evaporator.
9. Reconnect the water supply, restore power, and confirm normal operation.

Full Tube Removal and Cleaning

If the water distribution tube remains heavily restricted after basic clearing:

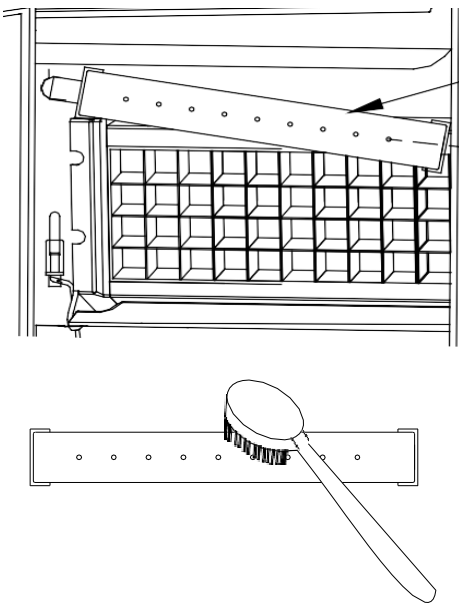

Figure E - Removing and Cleaning the Water Distribution Tube

1. Press **ON/OFF** to place unit in standby mode.
2. Disconnect power and shut off water supply.
3. Note the original position of the water distribution tube and spray holes before moving the tube. The spray holes must be returned to the same operating position after cleaning.
4. Disconnect the water hose from distribution tube.
5. Carefully remove the distribution tube.
6. Clean the tube using warm water and mild detergent.
7. Use a soft brush to remove mineral deposits or debris.
8. Rinse thoroughly using clean potable water.
9. Reinstall the distribution tube.
10. Rotate the water distribution tube back to its original operating position. Confirm the spray holes face the correct direction for normal water distribution across the evaporator. Reconnect the water supply line.
11. Inspect all connections for leaks.
12. Reinstall all panels securely.
13. Restore water supply and power.
14. Confirm normal water flow and ice production.

If water flow does not return to normal after cleaning, discontinue operation and contact qualified service personnel.

CLEANING AND MAINTENANCE

Recommended Cleaning and Maintenance Schedule

Regular cleaning and preventive maintenance are required to maintain ice quality, production capacity, sanitation, drainage performance, airflow, and long equipment life. Cleaning frequency depends on water quality, ambient conditions, installation environment, and operating usage.

Mineral scale, airborne grease, dust, slime buildup, restricted airflow, and poor drainage may reduce performance and increase the likelihood of service issues if the unit is not maintained regularly.

The following schedule is a general guideline. More frequent cleaning may be required in hard-water environments, high-temperature kitchens, greasy environments, high-volume operation, or areas with airborne dust or debris.

Component / Area	Recommended Frequency	Operator Guidance
Ice scoop	Daily	Wash and sanitize regularly. Store on the scoop holder when not in use.
Storage bin interior	Daily to weekly	Wipe clean, inspect for residue, slime, odor, or contamination.
Exterior surfaces	Daily	Wipe with mild detergent and warm water. Dry with a soft cloth.
Ice slideway area	Weekly	Confirm the ice slideway moves freely and is not blocked by ice, residue, or debris.
Drain inspection	Weekly	Confirm water drains freely with no backup, standing water, leaks, or restrictions.
Full cleaning and sanitizing	Every 3 to 12 months, or more often as required	Complete the full cleaning, descaling, rinsing, sanitizing, and ice-discard procedure.
Descaling procedure	As required by water conditions	Remove mineral scale when deposits, slow production, or irregular ice formation appear.
CLEAN reminder indicator	Whenever flashing repeatedly	Perform cleaning and descaling procedure and inspect for scale buildup or restricted water flow
Condenser inspection	Monthly	Check front grille and condenser area for dust, lint, grease, or blocked airflow.
Condenser cleaning	Monthly or as required	Vacuum condenser gently with a soft brush attachment. Do not use sharp tools or liquid cleaners.
Sediment filter inspection	Regularly	Check for reduced flow, discoloration, debris buildup, clogging, or leakage.
Sediment filter replacement	Approximately every 6 months or as required	Replace sooner if water flow slows, filter appears restricted, or water quality requires it.
Water supply and drain connections	Regularly	Check tubing, fittings, drain hose, and drain cap for leaks, damage, kinks, or loose connections.

TROUBLESHOOTING GUIDE

If the ice machine does not appear to be operating correctly, review the **Installation**, **Operation**, **Cleaning and Maintenance**, and **Shutdown Procedure** sections first. Many apparent problems are caused by restricted airflow, improper cleaning, mineral scale buildup, water supply problems, drain restrictions, environmental conditions, improper startup procedures, or cleaning-related conditions and may often be corrected without service.

Use the guide below to identify common symptoms, likely causes, and recommended corrective actions. If the issue persists after completing the recommended steps, discontinue use and contact qualified service personnel.

 <b style="font-size: 1.2em;">WARNING!	<p>If the issue involves smoke, burning odor, refrigerant odor, overheating, damaged power cord or plug, repeated breaker tripping, sparking, electrical shock risk, water intrusion into electrical areas, refrigerant-line damage, or any other unsafe condition, if safe to do so, disconnect power, shut off the water supply if leakage is present, and do not resume operation until the problem is corrected.</p>
---	--

 <b style="font-size: 1.2em;">WARNING!	<p>Disconnect power before inspection, cleaning, or maintenance. Do not attempt to bypass controls, remove panels, service sealed refrigeration components, or perform internal electrical repairs unless qualified to do so.</p>
---	---

Before Calling for Service

Before troubleshooting specific issues, confirm the following:

- The unit is connected to a properly grounded outlet matching the rating label requirements.
- The outlet has power and the circuit breaker has not tripped.
- The power cord and plug are undamaged and fully connected.
- If power was interrupted, the control panel has returned to standby mode and the **ON/OFF** button has been pressed to restart ice production.
- The unit has been installed with all required airflow clearances maintained.
- The front grille and condenser area are clean and unobstructed.
- The ambient temperature and water supply conditions are within the specified operating range.
- The water supply is turned on and water pressure is within specification.
- The water supply line is not kinked, restricted, frozen, disconnected, or leaking.
- The drain hose maintains proper downward slope without restriction, standing water, or backup.
- The drain cap is fully tightened.
- The ice slideway moves freely and is not blocked by ice or debris.
- The unit has been cleaned, descaled, and sanitized according to this manual.
- Mineral scale buildup, slime buildup, or restricted water flow are not present.
- The storage bin is not overfilled or obstructing normal operation.
- The unit has completed normal startup sequence and sufficient time has been allowed for ice production.
- The **CLEAN** reminder indicator is not flashing repeatedly due to overdue cleaning.
- Indicator lights and controller operation appear normal.

Many apparent equipment problems are resolved by correcting one of the above conditions.

Symptom	Possible Cause	Operator Action
Electrical Safety		
Circuit breaker trips repeatedly	Overloaded circuit, incorrect electrical supply, damaged outlet, moisture intrusion, internal electrical fault, or use of extension cord or adapter	Stop use. Remove extension cords, adapters, outlet splitters, or power strips. Confirm the unit is connected to a dedicated grounded outlet matching the rating label. If breaker trips again, disconnect power and contact qualified service personnel.
Power cord, plug, or outlet is hot, loose, damaged, or discoloured	Damaged electrical connection, overloaded circuit, poor outlet contact, incorrect receptacle, or electrical fault	Stop use immediately. Disconnect power if safe. Do not operate until the outlet, plug, and power cord have been inspected and corrected by qualified personnel.
Sparking, arcing, electrical shock, or electrical burning smell	Electrical fault, damaged wiring, moisture intrusion, or unsafe electrical condition	Stop use immediately. Press ON/OFF to place unit in standby if safe, disconnect power, and contact qualified service personnel.

TROUBLESHOOTING GUIDE

Symptom	Possible Cause	Operator Action
Unit has no power	Power cord unplugged, outlet has no power, breaker tripped, damaged cord or plug, or incorrect electrical supply	Confirm plug is fully connected, outlet has power, and breaker has not tripped. Do not use if cord, plug, or outlet is damaged.
Startup and Controls		
Unit does not start ice production	Unit is in standby, ON/OFF not pressed, bin full condition active, no power, or controller not energized	Confirm POWER indicator is on. Press ON/OFF . Confirm storage bin is not full and ice slideway moves freely.
Unit does not restart automatically after power outage	Unit returned to standby mode after power restoration	Press ON/OFF to resume ice production
All indicators illuminate after startup	Normal startup system check	No correction required. All indicators may illuminate for approximately 3 minutes during initial startup before ice production begins.
Unit starts but no ice appears immediately	Normal water fill and startup delay, first freeze cycle not complete, ambient or water temperature conditions affecting timing	Allow normal startup sequence to continue. First harvest may take up to approximately 60 minutes under normal conditions.
Unit was recently unplugged and does not restart normally	Compressor short-cycle protection needed or unit restarted too quickly	Wait at least 10 minutes before reconnecting power or restarting after power interruption.
Water Supply		
Water does not enter unit	Water supply shut off, kinked supply line, blocked sediment filter, low water pressure, disconnected supply line, or inlet restriction	Confirm water supply valve is open, supply line is not kinked, filter is not blocked, and pressure is within specification.
Slow fill or low water level	Low water pressure, restricted sediment filter, kinked line, partially closed shutoff valve, or inlet restriction	Check water supply valve, filter, supply line, and water pressure. Replace restricted filter if needed.
Water supply connection leaks	Loose fitting, damaged tubing, improper connection, overpressure, or tubing not fully seated	Shut off water supply. Tighten or reconnect fittings. Confirm tubing is fully seated and not damaged. Use pressure regulator if supply pressure exceeds specification.
Water pressure above 80 psi	Supply pressure exceeds rated operating range	Install a pressure reducing regulator before operating the unit.
Ice machine stops or faults due to lack of water	Water supply shut off, low pressure, restricted filter, kinked line, blocked inlet, or supply interruption	Turn on water supply, confirm pressure, inspect filter and tubing, then restart. If fault returns, contact qualified service personnel.
Drainage		
Water backs up into bin or drains slowly	Drain hose kinked, drain hose routed upward, insufficient slope, blocked drain, restricted floor drain, or submerged drain end	Confirm gravity drain slopes continuously downward at minimum required slope. Remove kinks, restrictions, and blockage.
Water leaks near rear drain connection	Loose drain hose, loose drain cap, damaged drain fitting, or drain restriction	Tighten drain cap and drain connections. Confirm drain hose is secure and unrestricted.
Standing water or odor near drain	Slow drain, slime buildup, poor slope, dirty drain area, or restricted termination point	Flush accessible drain areas with clean warm water. Clean visible slime and debris. Confirm drain flows freely.
Water appears on floor when door is opened	Normal meltwater or condensation carried with ice, excessive ice melt, frequent door opening, or drainage issue	Wipe water promptly to prevent slip hazard. Confirm drain is clear if water is excessive or persistent.
Drain test fails after installation	Improper drain slope, blocked line, loose connection, drain hose looped too high, or no air gap where required	Correct drain routing and slope. Pour water into bin and confirm free drainage before operation.
Ice Production		
Low daily ice production	High ambient temperature, warm inlet water, restricted airflow, dirty condenser, scale buildup, poor water flow, drain restriction, dirty filter, or installation near heat source	Clean condenser, verify clearances, confirm water supply and drain, clean/descale unit, replace restricted filter, and move heat sources away if possible.
Bin does not fill in expected time	Dirty condenser, restricted airflow, high ambient temperature, warm inlet water, scale buildup, water distribution problem, drain restriction, or excessive ice use	Check airflow, condenser, water supply, drain, cleaning condition, and operating environment. Allow several full cycles before judging production.
Production slows over time	Scale buildup, dirty condenser, restricted sediment filter, poor water quality, blocked water distribution tube, or reduced airflow	Perform cleaning/descaling, inspect filter, clean condenser, inspect water distribution tube if needed, and verify airflow.

TROUBLESHOOTING GUIDE

Symptom	Possible Cause	Operator Action
Unit runs continuously but produces little ice	Dirty condenser, high ambient temperature, warm water, low water flow, scale buildup, water distribution restriction, or refrigeration fault	Complete operator checks for airflow, water supply, condenser, drain, and descaling. Contact service if production does not improve.
Ice Quality		
Cubes are incomplete, hollow, thin, or white at bottom	Low water level, low pressure, restricted filter, scale buildup, blocked water distribution tube, poor water quality, or inlet restriction	Check water pressure, filter, supply line, cleaning condition, and water distribution tube. Clean/descale before adjusting settings.
Cubes are too thick	Incorrect ice size setting, low ambient temperature, cold inlet water, delayed harvest, or scale affecting harvest	Reduce ice thickness setting gradually. Allow several cycles before evaluating. Clean/descale if harvest is slow.
Cubes are too thin	Ice thickness setting too low, high ambient temperature, warm inlet water, insufficient water flow, or poor freeze time	Increase ice thickness setting gradually. Verify water supply, condenser cleanliness, and airflow.
Cubes are cloudy, soft, or poor quality	Poor incoming water quality, poor filtration, high mineral content, scale buildup, or sanitizer/cleaner residue	Replace or upgrade filtration, clean/descale and rinse thoroughly, discard ice until odor/taste/residue is gone.
Ice has unusual odor or taste	Dirty bin, stagnant ice, cleaning chemical residue, poor water quality, contaminated scoop, or old ice	Discard ice, clean and sanitize bin and scoop, rinse water system, replace filter if needed, and produce fresh ice.
Ice is irregular after cleaning	Normal temporary post-cleaning condition, air in lines, water conditions stabilizing, or residual cleaning cycle effects	Continue discarding ice as instructed. Condition should correct after several harvests.
Harvest and Bin Full		
Ice does not release or harvest is slow	Scale buildup, ice too thick, dirty evaporator, unit not level, low ambient temperature, water distribution problem, or refrigeration issue	Clean/descale, verify level, check ice thickness setting, and allow several cycles. Contact service if harvest remains slow.
Repeated harvest failure indication	Ice stuck on evaporator, scale buildup, ice slideway obstruction, ice thickness too high, low temperature conditions, or component issue	Remove obstruction, clean/descale, verify ice slideway moves freely, adjust ice thickness only gradually. Contact service if repeated.
Unit stops because bin full indicator is on	Storage bin full or ice slideway held open by ice	Remove ice and confirm ice slideway returns freely.
Bin full indicator stays on when bin is not full	Ice slideway blocked, bent, dirty, frozen, or sensor/magnet issue	Check ice slideway area for ice, debris, or obstruction. Do not force or bend ice slideway. Contact service if indicator remains on.
Ice packs tightly near ice slideway	Improper ice removal, ice stored too long, ice bridging, or bin overfilled	Break up stored ice carefully without damaging ice slideway. Remove enough ice so ice slideway moves freely.
Water Distribution		
Water does not flow evenly across evaporator	Blocked water distribution tube, scale buildup, low water pressure, restricted filter, or kinked supply line	Confirm water pressure, filter, and supply line. Clean/descale first. If needed, inspect and clean water distribution tube.
Ice pattern incomplete across evaporator	Uneven water distribution, blocked tube holes, low water level, unit not level, or scale buildup	Level unit, clean/descale, check water supply, and inspect distribution tube if problem continues.
Excessive splashing during operation	Water flow irregularity, recent cleaning, air in water system, incorrect component position, scale buildup, or drain restriction	Allow several cycles after cleaning. If persistent, inspect water distribution, drain, and scale condition.
Cleaning and Maintenance		
CLEAN indicator flashes	Cleaning reminder active, scale buildup likely, cleaning interval reached	Perform full cleaning and descaling procedure. Increase cleaning frequency if in hard-water or high-use environment.
Scale appears frequently	Hard water, inadequate filtration, no scale inhibition, long cleaning interval, or high mineral content	Increase descaling frequency. Use appropriate ice-machine-rated filtration with scale inhibition if local water requires it.
White mineral deposits visible	Scale buildup from hard water or insufficient descaling	Clean and descale unit. Inspect water quality and filtration.
Slime, odor, or residue in bin	Infrequent bin cleaning, old ice, poor sanitation, warm environment, or contaminated scoop	Discard ice. Clean and sanitize bin, scoop, and food-contact areas.

TROUBLESHOOTING GUIDE

Symptom	Possible Cause	Operator Action
Cleaning chemical odor remains after cleaning	Insufficient rinsing or chemical residue in water system	Repeat clean-water rinse cycle and discard ice until odor/taste is gone.
First ice after cleaning is irregular	Normal post-cleaning stabilization or residual air/water condition	Discard first two batches and continue operation until normal appearance returns.
Condenser and Airflow		
High temperature fault or protective shutdown	Dirty condenser, blocked grille, restricted clearance, high ambient temperature, or installation near heat source	Clean condenser, clear front grille, confirm rear/top/side clearances, reduce nearby heat, and restart after conditions normalize.
Compressor runs longer than usual	Dirty condenser, restricted airflow, high ambient temperature, warm water, scale buildup, or heavy demand	Clean condenser, verify airflow, descale, and confirm operating environment.
Condenser is dirty	Dust, lint, grease, or airborne debris buildup	Vacuum gently with soft brush attachment after disconnecting power. Do not use sharp tools, liquids, or high-pressure air.
Leaks and Moisture		
Water leaks from unit	Water supply leak, drain leak, loose drain cap, blocked drain, overflowing bin, or internal leakage	Shut off water supply if leakage continues. Check supply fittings, drain hose, and drain cap. Contact service if source is internal.
Drain cap leaks	Loose nut, damaged seal, debris on sealing surface, or not reinstalled after cleaning	Tighten securely. Inspect for debris or damage. Do not operate if leak continues.
Condensation around bin or door	Warm humid environment, frequent door opening, melting ice, normal moisture, or poor drain	Keep door closed, confirm drain works, and wipe water promptly. Investigate if heavy or persistent.
Floor becomes wet	Drain overflow, leak, condensation, ice melt, or water spilled during ice removal	Clean water immediately to prevent slip hazard. Check drain and water connections.
Noise and Vibration		
Rattling noise	Water line vibration, unit not level, loose panel, object on top of unit, or normal refrigerant flow	Remove items from top, confirm level, check panels and water line. Contact service if noise persists.
Grinding, scraping, banging, or severe vibration	Fan obstruction, damaged component, loose internal part, or unsafe mechanical condition	Stop use, disconnect power, and contact qualified service personnel.
Installation and Environment		
Unit stops suddenly during operation	Power interruption, temperature outside operating range, blocked airflow, low voltage, dirty condenser, or protective shutdown	Confirm power, airflow, condenser cleanliness, ambient temperature, and water supply. Restart only after correcting conditions.
Unit was tilted, moved, or laid on side	Compressor oil migration risk or internal water disturbance	Keep upright and disconnected from power for at least 24 hours if tilted excessively or transported non-upright.
Unit exposed to freezing conditions	Water frozen inside lines, valves, pump, drain, or internal water system	Do not operate until inspected and safely thawed. Drain completely before storage in freezing conditions. Contact service if damage is suspected.
Sanitation and Ice Handling		
Foreign material in ice	Debris in bin, dirty scoop, packaging, contaminated water, or poor sanitation	Discard ice. Clean and sanitize bin and scoop. Inspect water source and bin.
Scoop is dirty or stored in ice	Improper scoop storage or poor handling practices	Clean and sanitize scoop. Store on interior side-wall scoop holder.
Non-ice items found in bin	Bottles, food, tools, packaging, or other items stored in ice bin	Remove items, discard affected ice, clean and sanitize bin. Do not store anything except ice in the bin.

When to Stop and Call for Service

Stop using the unit, press **ON/OFF** to place the unit in standby mode, disconnect power from the electrical outlet, shut off the water supply if leakage is present, and contact qualified service personnel if any of the following occur:

- Unit does not produce ice after normal startup, water supply, airflow, drain, and cleaning checks.
- Circuit breaker trips repeatedly or the unit repeatedly loses power during operation.
- Power cord, plug, receptacle, controls, indicator lights, front panel, door, ice slideway, water line, drain line, or housing becomes damaged.
- Electrical odor, smoke, sparks, arcing, overheating, or electrical shock risk is observed.
- Unit overheats, shuts down unexpectedly, or repeatedly shows high-temperature fault indications.
- Fan, compressor, pump, water valve, or controller operation is abnormal after normal operator checks.
- Repeated fault indicators occur after airflow, water supply, drain, cleaning, and installation is checked.
- Water leakage, drain backup, overflow, or standing water continues after normal operator corrections.
- Ice harvest failure continues after cleaning, descaling, level verification, ice slideway inspection, and ice thickness adjustment checks.
- Unit repeatedly shows lack-of-water indication after confirming water supply, pressure, filter condition, and supply line routing.
- Ice production remains low after condenser cleaning, descaling, water supply checks, and airflow checks.
- Ice develops persistent unusual odor, taste, discoloration, debris, or contamination concerns after cleaning, sanitizing, flushing, and filter checks.
- Ice slideway, door, hinges, gasket, controls, water-system components, drain components, or internal components become loose, damaged, obstructed, or unsafe.
- Unit has been dropped, impacted, tipped, exposed to flooding, exposed to freezing conditions, or liquid has entered electrical or internal areas.
- Refrigerant tubing appears damaged or a refrigerant leak is suspected.
- Abnormal noise, vibration, overheating, water flow problems, or airflow problems continue after cleaning and normal operating corrections.
- Unit continues to operate abnormally after recommended operator-level troubleshooting is completed.
- Internal electrical service, controller replacement, pump replacement, fan service, valve replacement, sensor replacement, sealed refrigeration-system service, refrigerant handling, compressor service, wiring repair, or internal disassembly is required.

Do not attempt to repair internal electrical, refrigeration, water-system, control, wiring, or sealed-system components unless qualified. Unauthorized repair or modification may result in injury, electrical shock, refrigerant hazard, fire hazard, water leakage, contamination, equipment damage, or affected warranty coverage.

Fault Indicator Codes

When the controller detects certain abnormal operating conditions, one or more indicator lights may flash in a specific pattern. The unit may continue operating, pause temporarily, or stop certain functions depending on the condition detected.

When contacting service, report the flashing indicator pattern exactly as observed, including which indicators are flashing and whether they are flashing alone or together. If a fault indication occurs:

1. Press **ON/OFF** to place the unit in standby mode.
2. Inspect the condition shown in the chart below.
3. Correct any operator-level issue such as blocked airflow, closed water supply, kinked water line, restricted drain, dirty condenser, scale buildup, or blocked ice slideway.
4. Restart the unit after the condition has been corrected.
5. If the same fault indication returns, discontinue use and contact qualified service personnel.

Do not attempt to disassemble, bypass, repair, or service internal electrical, refrigeration, controller, sensor, valve, pump, or wiring components unless qualified to do so.

Fault Condition	Indicator Pattern	Operator Action
Evaporator temperature sensor failure	ICE indicator flashes rapidly	Disconnect power and contact qualified service personnel.
Condenser temperature sensor failure	CLEAN indicator flashes rapidly	Disconnect power and contact qualified service personnel.
High temperature protection	CLEAN indicator flashes very rapidly	Confirm front grille and condenser airflow openings are unobstructed. Check rear, top, and side clearances. Confirm ambient temperature is within specification. Clean condenser if dirty. Restart the unit after conditions are corrected. If the fault returns, contact qualified service personnel.
Ice harvest failure	ICE and BIN FULL indicators flash together	Confirm the storage bin is not overfilled and the ice slideway moves freely. Check for excessive ice thickness, scale buildup, blocked airflow, or abnormal ice formation. Clean and descale if needed. Restart the unit. If the fault returns, contact qualified service personnel.
Lack of water	BIN FULL and CLEAN indicators flash together	Confirm the water supply is turned on, inlet pressure is within specification, the supply line is not kinked, and the sediment filter is not restricted. Restart the unit after correcting the issue. If the fault returns, contact qualified service personnel.

- Flashing speed may vary. Focus on which indicator lights are flashing and whether flashing alone or together.
- Repeated fault indications may result from restricted airflow, water supply problems, drain restrictions, scale buildup, dirty condenser surfaces, poor ventilation, abnormal environmental conditions, or component failure.
- Operating the unit outside the published ambient temperature, water temperature, water pressure, airflow, or installation limits may trigger protective shutdown.
- If smoke, electrical odor, overheating, refrigerant leak concern, water intrusion into electrical areas, damaged wiring, or unsafe operation is observed, disconnect power and stop operation immediately.

WARRANTY, SERVICE, AND SPARE PARTS

Warranty

For full warranty terms, conditions, limitations, and exclusions, please visit:

<https://noriota.ca/pages/warranty-policy>

To register your product online, visit:

<https://noriota.ca/pages/warranty-registration>

Please have your model number and serial number available when registering your product or requesting warranty support.

Scan to register your product online:



Spare Parts

Replacement parts diagrams and component identification resources are available at:

www.noriota.ca

Search by model number and verify the model and serial number before ordering parts. Use only approved replacement parts intended for this model. Parts diagrams are for identification only and do not replace qualified service procedures.

Rating Label Information

The rating label is located on the unit in a visible service-access location. The exact location may vary by model. The rating label contains important technical and identification information for the unit, including:

- Model number
- Serial number
- Electrical rating
- Voltage
- Frequency
- Power consumption
- Refrigerant information
- Certification information, including applicable safety and sanitation standards

Always verify that the electrical supply matches the requirements shown on the rating label before operation.

Do not remove, cover, deface, paint over, or damage the rating label. The rating label must remain legible for the life of the equipment.

COMMISSIONING RECORD

Record the information below at the time of installation. This record helps confirm proper installation conditions, supports future service, and may assist in warranty evaluation. Retain this page for your records.

UNIT AND PURCHASE INFORMATION

Model Number: _____

Serial Number: _____

Date of Purchase: _____

Purchased From (Dealer / Supplier): _____

Dealer Contact (if available): _____

INSTALLATION DETAILS

Installation Date: _____

Installation Location (Site / Address): _____

Installed By (Company / Technician Name): _____

Installer Contact (if available): _____

<p>ELECTRICAL AND WATER SUPPLY VERIFICATION</p> <p>Electrical Supply Voltage: _____ <input type="checkbox"/> Verified matches rating label specification</p> <p>Frequency: _____ <input type="checkbox"/> Verified matches rating label specification</p> <p>Dedicated Grounded Outlet Verified: <input type="checkbox"/> Yes <input type="checkbox"/> No</p> <p>Water Pressure Within Specification: <input type="checkbox"/> Yes <input type="checkbox"/> No</p> <p>Incoming Water Temperature: _____</p> <p>Included Sediment Filter Installed and Connected Correctly: <input type="checkbox"/> Yes <input type="checkbox"/> No <input type="checkbox"/> N/A</p> <p>Anti-Scale Filter Installed (Not Included): <input type="checkbox"/> Yes <input type="checkbox"/> No Filter Model / Specification: _____</p>	<p>INSTALLATION AND UNIT SETUP</p> <p>Unit Level and Stable: <input type="checkbox"/> Yes <input type="checkbox"/> No</p> <p>Drain Connection Installed Correctly: <input type="checkbox"/> Yes <input type="checkbox"/> No</p> <p>Drain Hose Maintains Proper Downward Slope: <input type="checkbox"/> Yes <input type="checkbox"/> No</p> <p>Required Airflow Clearances Maintained: <input type="checkbox"/> Yes <input type="checkbox"/> No</p> <p>Front Grille and Airflow Unobstructed: <input type="checkbox"/> Yes <input type="checkbox"/> No</p> <p>Water Supply and Drain Connections Leak-Free: <input type="checkbox"/> Yes <input type="checkbox"/> No</p> <p>Ice Slideway Moves Freely: <input type="checkbox"/> Yes <input type="checkbox"/> No</p> <p>Installed Away from Heat Sources and High-Temperature Equipment: <input type="checkbox"/> Yes <input type="checkbox"/> No</p> <p>Ambient Air Temperature at Installation: _____</p>
<p>INITIAL STARTUP AND OPERATION CHECK</p> <p>POWER Indicator Operates Correctly: <input type="checkbox"/> Yes <input type="checkbox"/> No</p> <p>ICE Indicator Operates Correctly: <input type="checkbox"/> Yes <input type="checkbox"/> No</p> <p>Water Fill Operation Functions Correctly: <input type="checkbox"/> Yes <input type="checkbox"/> No</p> <p>Ice Production Cycle Starts Normally: <input type="checkbox"/> Yes <input type="checkbox"/> No</p> <p>Harvest Cycle Functions Correctly: <input type="checkbox"/> Yes <input type="checkbox"/> No</p> <p>Automatic Bin-Full Operation Verified: <input type="checkbox"/> Yes <input type="checkbox"/> No</p> <p>Abnormal Noise, Vibration, Leakage, Odor, or Fault Indicators Present: <input type="checkbox"/> Yes <input type="checkbox"/> No - if yes, discontinue use and investigate before operation</p>	<p>CLEANING AND FINAL COMMISSIONING</p> <p>Initial Cleaning and Sanitizing Completed: <input type="checkbox"/> Yes <input type="checkbox"/> No</p> <p>First Two Ice Batches Discarded: <input type="checkbox"/> Yes <input type="checkbox"/> No</p> <p>Customer or Operator Received Basic Operating Instructions: <input type="checkbox"/> Yes <input type="checkbox"/> No</p> <p>User Manual Provided to Operator: <input type="checkbox"/> Yes <input type="checkbox"/> No</p> <p>Final Operational Check Completed: <input type="checkbox"/> Yes <input type="checkbox"/> No</p>

NOTES / OBSERVATIONS

INSTALLER CONFIRMATION

Installer Name: _____

Signature: _____

Date: _____

6 Loring Drive, Bolton, Ontario L7E 1H5 | 1-877-667-4682 (1-877-NORIOTA)
support@noriota.ca
www.noriota.ca

© 2026 NORIOTA. All rights reserved.