

NORIOTA

INSTALLATION AND INSTRUCTION MANUAL

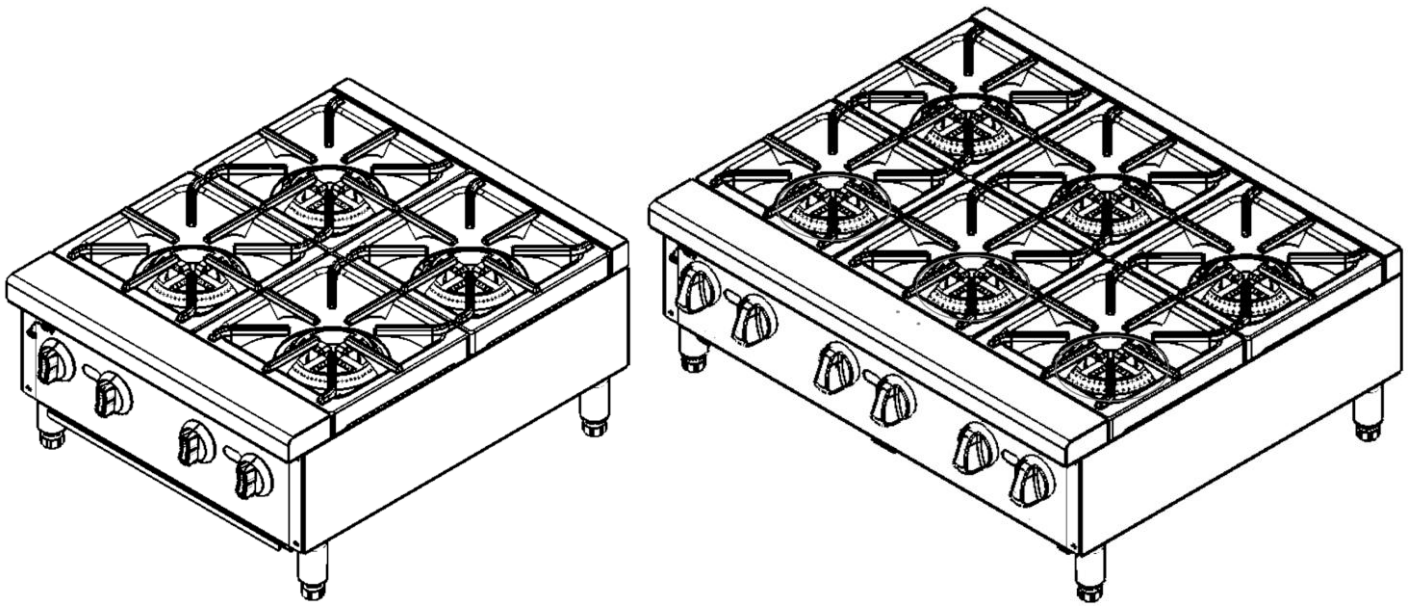

HOTP AND NHP SERIES GAS COUNTERTOP HOT PLATES

OPERATOR SAFETY AND OPERATING TIPS

Quick Reference Only - Follow Full User Manual



NOTICE!

This guide highlights important safety and operating reminders only. It does not replace the full Installation and Instruction Manual. Read and follow the full manual before installing, operating, cleaning, or servicing this unit.



WARNING!

Improper installation, gas connection, ventilation, or operation can cause fire, explosion, carbon monoxide exposure, serious injury, or death. Only **qualified personnel** should install or service this equipment.

Before Each Use

- Confirm the unit is level, stable, and installed under a properly operating ventilation hood.
- Confirm the manual gas shutoff valve is accessible.
- Confirm the drip tray is installed, properly seated, and not full.
- Confirm nothing is blocking airflow at the front, underside, rear, or flue area of the unit.

Do not operate if installation, ventilation, gas supply, or drip tray conditions are not correct.

Critical Safety Reminders



WARNING!

If gas odor is present, shut down the unit if safe to do so, evacuate the area, and follow site gas emergency procedures. Do not attempt to relight or resume operation until the condition is corrected and the area has been declared safe.



WARNING!

For ignition failure, pilot outage, abnormal flame, delayed ignition, or abnormal operation, shut down immediately and contact **qualified service personnel**.

- This unit does not include an automatic flame failure safety shutoff device. Confirm pilots are lit and stable before turning **ON** any burner controls.
- Each pilot serves one burner pair. The pilot is located between the two control knobs for that burner pair. Left knob controls the rear burner. Right knob controls the front burner.
- If any pilot goes out, shut off all burner controls and shut off the gas supply at the manual gas shutoff valve. Do not continue operating the unit.
- Never use an open flame to check for gas leaks.
- Never store or use flammable liquids near this equipment.
- Do not leave the unit unattended during operation.
- Keep hands, clothing, towels, utensils, and packaging away from hot surfaces and open flames.
- Do not move or handle cast iron grates or the drip tray while unit or grease is hot.
- Do not use water on a grease fire.

Cooking, Operating, and Cleaning Tips

- Allow proper preheat before loading cookware.
- Use cookware that is stable and suitable for commercial open-burner cooking.
- Do not overload the grates or use oversized cookware that blocks airflow or traps heat.
- Monitor accumulation in the drip tray and do not allow overflow.
- Reduce flame during idle periods.
- Clean cast iron grates, drip tray, and accessible surfaces regularly.

Normal Operation

- Burner pilots remaining lit
- Light smoke or odor during first use or burn-off
- Heat variation between cooking zones
- Slight discoloration of stainless steel or cast iron

These are normal operating characteristics.

Need Help

For product support, manuals, or service assistance:



Website
www.noriota.ca



Phone
1-877-NORIOTA



Email
support@noriota.ca

Please have your model and serial number available when contacting support.

TABLE OF CONTENTS

INTRODUCTION.....	3
RECEIVING AND INSPECTING THE EQUIPMENT.....	5
Reporting Damage.....	5
Serial Number Information.....	5
SAFETY INFORMATION.....	6
Fire Hazard - For Your Safety.....	6
Burn Hazard.....	6
If Gas Odor Is Detected.....	6
General Safety Instructions.....	7
Gas Safety.....	7
Cooking Fire Hazard.....	7
Installation Safety.....	8
Ventilation and Airflow Safety.....	8
Cooking Operation Safety.....	8
Open Flame and Cookware Safety.....	8
Cleaning and Maintenance Safety.....	9
Service and Repair Safety.....	9
IMPORTANT SAFEGUARDS.....	10
Gas Connection Requirements.....	10
Ventilation and Fire Code Compliance.....	10
Unit Disposal.....	10
INSTALLATION.....	11
Installation Responsibility and Code Compliance.....	11
Pre-Installation Checklist.....	11
Location and Placement Requirements.....	11
Clearance Requirements.....	11
Ventilation and Hood Requirements.....	12
Leveling the Unit.....	12
Component Setup Before Operation.....	12
Gas Supply Requirements.....	13
Gas Connection Procedure.....	13
Gas Pressure Regulator.....	13
Leak Testing Procedure.....	14
Pilot and Burner Verification During Installation.....	14
Final Installation Checks.....	14
OPERATION.....	16
Control System Overview.....	16
How the Hot Plate Works.....	16
Before First Use.....	16
Initial Burn-Off Procedure.....	16
Lighting the Pilots.....	17
Burner Controls.....	18
Startup Procedure.....	19
Normal Operation.....	19
Heat Zone and Cookware Management.....	19
Hot Plate Operation Best Practices.....	20
Abnormal Operating Conditions.....	20
Shutdown Procedure.....	21
Gas Conversion.....	21
CLEANING AND MAINTENANCE.....	22
Cleaning and Maintenance Safety.....	22
General Maintenance Guidance.....	22
During-Use Cleaning.....	23
End-of-Day Cleaning.....	23
Cast Iron Grate Cleaning.....	23
Drip Tray Cleaning.....	23
Exterior and Stainless Steel Cleaning.....	24
Burner and Pilot Area Inspection.....	24
Flue and Ventilation Area Inspection.....	24
Reassembly and Drying.....	25
Area Around and Beneath the Unit.....	25
Preventive Maintenance and Service Boundary.....	25
Recommended Maintenance Schedule.....	25
Final Maintenance Reminder.....	26
Maintenance Log.....	26
TROUBLESHOOTING GUIDE.....	27
WARRANTY.....	31
SPARE PARTS AND SERVICE INFORMATION.....	32
COMMISSIONING RECORD.....	33

INTRODUCTION

This manual provides installation, operation, cleaning, and maintenance instructions for NORIOTA commercial gas countertop hot plates. These units are designed for professional use in commercial kitchens, foodservice operations, and similar environments. Proper installation, operation, and maintenance are essential for safe use, consistent cooking performance, and long equipment life.

This manual applies to NORIOTA gas countertop hot plate models NHP12, NHP24, NHP36, HOTP12, HOTP24, and HOTP36. Always refer to the unit rating label for exact technical information including gas type, pressure requirements, input rating, certification information, and clearance requirements.

Commercial gas hot plates are high-output cooking appliances that use open gas burners, standing pilots, cast iron grates, and manual burner controls to heat cookware directly. Unlike residential cooking appliances, commercial hot plates operate at higher heat output, require commercial ventilation, and must be installed with proper gas supply, combustion air, clearances, and operator supervision.

Each burner is controlled by an individual manual control knob. Each burner pair is served by one standing pilot located between the two control knobs. The left knob controls the rear burner. The right knob controls the front burner. Burner output is adjusted manually by the operator and is not thermostat-controlled.

Improper installation or operation can result in gas accumulation, delayed ignition, fire, burns, carbon monoxide exposure, unstable flame, poor cooking performance, equipment damage, or unsafe operating conditions. Particular attention must be given to gas supply, ventilation, clearance, pilot lighting, shutdown procedures, cleaning practices, drip tray management, and proper operator training.

Important Information for Owners and Operators

- Read this manual completely before installing or operating the equipment.
- Installation, gas connection, gas conversion, and servicing must be performed by **qualified personnel** in accordance with applicable local codes and regulations.
- This equipment is intended for commercial foodservice use only. It is not intended for household, residential, or other non-commercial use.
- Improper installation, use, or maintenance may result in personal injury, fire hazard, equipment damage, unsafe operating conditions, or reduced performance.
- Do not operate the unit if pilots do not light properly, burners do not ignite promptly, flame appears unstable, or ventilation is not operating correctly.
- This unit does not include an automatic flame failure safety shutoff device. Operators must confirm pilots are lit and stable before opening burner controls.
- If any pilot goes out, shut down the entire unit by turning all control knobs **OFF** and closing the manual gas shutoff valve. Do not continue operating the unit.
- Cooking performance, cookware selection, heat management, cleaning practices, drip tray condition, and ventilation directly affect safety, food quality, and equipment life.
- Keep this manual in a readily accessible location for reference by operators and service personnel.

Following these guidelines will help ensure safe operation, consistent performance, and long equipment life. Failure to follow these instructions may result in unsafe conditions, equipment damage, or voiding of warranty.

Intended Use

NORIOTA commercial gas countertop hot plates are designed and manufactured for commercial foodservice environments, including restaurants, cafés, bars, catering operations, institutional kitchens, commissaries, and similar applications. These units are intended for heating cookware on open gas burners using commercial-grade manual burner controls.

The equipment is designed for indoor use only and must be installed in a location that meets all requirements for gas supply, ventilation, clearance, combustion air, and safe operation as outlined in this manual. The hot plate is intended to be operated by trained personnel familiar with commercial cooking equipment, open gas burners, hot cookware, and basic gas equipment safety practices.

This equipment must not be used for any purpose other than commercial food preparation. It must not be used for space heating, drying materials, heating non-food items, heating sealed containers, processing chemicals, or any application inconsistent with the instructions provided in this manual.

INTRODUCTION

Use outside of the intended application may result in unsafe conditions, equipment damage, fire hazard, poor performance, or affected warranty coverage.

Residential Installation Considerations

NORIOTA commercial gas countertop hot plates are designed and manufactured for commercial foodservice use only. They are not intended for residential or household use.

Commercial hot plates differ materially from residential cooking appliances in heat output, open flame exposure, ventilation requirements, clearance requirements, gas supply requirements, and overall safety considerations. These units are designed for installation and operation in commercial kitchens or similar professional environments where appropriate gas supply, commercial ventilation, fire safety measures, trained operators, and code-compliant installation conditions are in place.

Residential or household installation or use is not recommended and may be prohibited by local code, insurance requirements, or authority having jurisdiction. Use of this equipment in a residential or non-commercial setting may create unsafe operating conditions, increase fire risk, result in improper ventilation, and may affect warranty coverage.

This equipment must be installed and operated only in suitable commercial environments and only in accordance with this manual and all applicable local codes and regulations.

Manual Scope and Updates

This manual contains important safety, installation, operation, and maintenance instructions. Following these instructions will help ensure safe operation, consistent cooking performance, and long equipment life.

This manual is intended to provide guidance for normal operation and routine maintenance. Advanced service procedures, gas system adjustments, burner adjustment, pilot adjustment, and internal component repairs must be performed by **qualified service personnel** only.

NORIOTA reserves the right to update product design, specifications, and documentation without notice. While reasonable efforts are made to ensure accuracy, users must always follow applicable local codes and regulations and consult qualified professionals when required.

Failure to follow the instructions and guidelines in this manual may result in personal injury, equipment damage, unsafe operating conditions, or reduced performance.

RECEIVING AND INSPECTING THE EQUIPMENT

Carefully inspect the equipment immediately upon delivery and before signing the carrier's delivery receipt.

Inspect the exterior packaging for visible signs of damage, including dents, punctures, crushed corners, broken components, pallet damage, or other evidence of mishandling in transit. If visible damage is observed, note the damage clearly on the delivery receipt and request that the carrier acknowledge it. Retain a copy of the signed delivery receipt for your records.

After the unit has been delivered and unpacked, inspect the unit itself for concealed damage. Check the exterior panels, cast iron grates, control knobs, drip tray, legs, gas connection, regulator, and all visible components for freight-related damage or missing parts. If concealed damage is discovered, notify the delivering carrier promptly and request an inspection. All freight damage claims must be filed with the carrier, as shipping damage is the responsibility of the carrier and is not covered under warranty.

Do not install, connect gas, or place the unit into service until the inspection process is complete. Retain all packaging materials until any freight damage claim has been resolved or carrier inspection has been waived.

Important Handling Notes

- Keep the unit upright during handling at all times. Do not tip, drop, or subject the unit to impact.
- Do not remove the unit from the delivery area or proceed with installation before completing the inspection.
- Do not use the control knobs, drip tray, gas manifold, or front ledge to lift or move the unit.
- The unit is heavy. Use appropriate material-handling equipment and sufficient personnel to move, lift, or position the unit safely.
- If the carrier is unable or unwilling to allow adequate inspection time, note this clearly on the delivery receipt before signing.
- Retain all packaging materials until the inspection process is complete.

Reporting Damage

- **Visible damage:** Must be noted on the delivery receipt at the time of delivery.
- **Concealed damage:** Must be reported to the carrier immediately upon discovery.

Failure to follow these procedures may affect the ability to file a freight damage claim.

Before Installation

Confirm the following before proceeding:

- The rating label is present and legible.
- The model number matches your purchase order.
- The gas type shown on the rating label matches the installation site requirements.
- The unit has not been damaged during transit.
- All shipped accessories and components are present.
- Cast iron grates, drip tray, control knobs, legs, gas regulator, gas conversion components, and other supplied parts are present and undamaged.
- The manual gas shutoff valve and site gas connection requirements have been reviewed by qualified installation personnel before installation begins.

Serial Number Information

The model and serial number are located on the unit rating label. Always have the model number and serial number available when contacting NORIOTA or an authorized service provider for parts, service, or technical support.

Final Receiving Reminder

Do not proceed with installation until the unit has been fully inspected and any shipping damage, missing parts, or documentation issues have been identified and addressed. Early inspection is the owner's best protection against freight disputes, installation delays, and avoidable service issues.

SAFETY INFORMATION

Commercial gas countertop hot plates operate at high temperatures and use open gas burners, standing pilots, and exposed flame. Improper installation, operation, or maintenance may result in fire, burns, explosion, carbon monoxide exposure, equipment damage, or unsafe operating conditions. Read and follow all safety instructions in this manual before installing, operating, cleaning, or servicing this equipment.



This is the Safety Alert Symbol. This symbol alerts you to potential hazards that can injure or kill you and others. All safety messages will follow the Safety Alert Symbol and either the words “DANGER”, “WARNING” or “CAUTION”.

**DANGER!**

This symbol indicates a hazardous situation which will result in death or serious injury.

**WARNING!**

This symbol indicates a hazardous situation or unsafe practice which, if not avoided, could result in death or serious injury.

**CAUTION!**

This symbol indicates a potential hazard or unsafe condition that may result in injury, equipment damage, or property damage.

**NOTICE!**

This symbol indicates important information related to proper use, installation, or maintenance of the equipment that does not involve a personal injury hazard.

All safety messages identify the hazard, explain how to reduce the risk, and describe the possible consequences if instructions are not followed.

**WARNING!****Fire Hazard - For Your Safety**

- Keep the area around the unit free and clear of combustible materials.
- Do not store or use gasoline or other flammable vapors or liquids near this or any other appliance.
- The operator must ensure that instructions to be followed in the event of a gas odor are posted in a prominent location. Obtain these instructions from the local gas supplier.

**WARNING!****Burn Hazard**

- Contact with burners, cast iron grates, cookware, flue components, or surfaces can cause burns.
- Use caution when operating the unit or handling hot cookware and components.
- Always use appropriate protective equipment when handling hot cookware or components.
- Do not touch hot surfaces, flue components, grease areas, or metal parts during or immediately after operation.

**WARNING!****If Gas Odor Is Detected**

- Do not attempt to light any appliance.
- Shut off the gas supply at the manual gas shutoff valve if it is safe to do so.
- Do not operate electrical switches or create ignition sources.
- Do not use a telephone in close proximity to the unit.
- Evacuate the area, follow site emergency procedures, and contact the local gas supplier immediately from a safe location.
- Do not return to the area until it has been declared safe.

**WARNING!****General Safety**

- Do not operate if burners do not ignite properly or flame appears unstable, lifting, yellow, or sooty.
- Do not leave the unit unattended during operation.
- Do not use the unit as a storage surface.
- Keep the drip tray clean and do not allow grease to overflow.

SAFETY INFORMATION



NOTICE!

- This equipment is intended for commercial foodservice use only. It is not intended for household, residential, or other non-commercial use.
- Installation, gas connection, and service must be performed by **qualified personnel** in accordance with all applicable local codes and regulations.
- Use of non-approved parts, improper installation, or unauthorized service may result in unsafe conditions and may affect warranty coverage.

General Safety Instructions

- This equipment must be installed, operated, and maintained in accordance with this manual.
- Do not operate the unit unless all components are properly installed, including cast iron grates and drip tray.
- Do not operate the unit if it has been damaged, is not functioning properly, or shows signs of unsafe operation.
- This equipment is heavy. Use appropriate lifting equipment and sufficient personnel when moving or positioning the unit. Improper handling may result in injury or equipment damage.
- Keep the area around the unit free of combustible materials, including paper, cardboard, cloth, plastics, and flammable liquids.
- Do not store or use gasoline or other flammable vapors or liquids in the vicinity of this or any other gas appliance.
- Never leave the unit unattended while in operation.
- Ensure adequate ventilation is provided at all times during operation. Do not operate the unit if the ventilation system is not functioning properly.

Gas Safety



WARNING!

Incorrect gas type, improper connection, gas leaks, or incorrect conversion may result in fire, explosion, carbon monoxide exposure, equipment damage, serious injury, or death. Verify gas type and perform leak testing before operation.



WARNING!

This unit does not include an automatic flame failure safety shutoff device. Operators must ensure the pilot flame is lit and stable before opening the corresponding burner control. Opening a burner control without a stable pilot flame may allow unburned gas to accumulate and may result in fire, explosion, serious injury, or death.



CAUTION!

Never use an open flame to check for gas leaks. Use approved leak-testing methods only.

- Verify that the gas type supplied matches the gas type indicated on the rating label.
- This unit may be field convertible between Natural Gas and LP Gas only by **qualified service personnel** using approved components and procedures.
- Do not attempt gas conversion, regulator adjustment, burner adjustment, or pilot adjustment unless qualified to do so.
- All gas connections must be leak tested before placing the unit into operation.
- Use only approved gas supply components and installation practices.
- Ensure the manual gas shutoff valve is accessible at all times.
- Do not operate the unit if gas connections are loose, damaged, or leaking.
- Use a soap-and-water solution or other approved leak-testing method only.
- If a pilot goes out, ignition fails, or any gas control has been turned **OFF**, wait at least 5 minutes before attempting to relight. This waiting period allows unburned gas to dissipate.

Cooking Fire Hazard



WARNING!

Open flame, hot surfaces, grease, and food drippings can create a fire hazard. Improper response can cause serious injury, death, or extensive property damage.

If a cooking fire or uncontrolled flare-up occurs:

- Turn off all burner controls if it is safe to do so.
- Turn off the gas supply at the shutoff valve if it is safe to do so.
- Use the fire suppression system or an appropriate fire extinguisher for the type of fire.
- Do not use water on a grease fire.

SAFETY INFORMATION

- Do not attempt to move the unit or remove the drip tray during a fire.
- Follow site emergency procedures and contact emergency services if required.

Never attempt to move the unit during a fire.

Installation Safety



WARNING!

Improper installation may result in fire, tipping, gas leakage, poor combustion, carbon monoxide exposure, or unsafe operation. Installation must be performed by **qualified personnel** in accordance with applicable codes and this manual.



WARNING!

Do not install or operate the unit without all legs properly installed. Operating the unit without legs may result in unstable conditions, improper clearance, poor combustion air supply, and increased risk of fire or injury.

- Install the unit only on a level, stable surface capable of supporting the equipment and normal cooking load.
- The unit must be level front-to-back and side-to-side.
- Legs must be properly installed before operation.
- Maintain required clearances from combustible and non-combustible materials at all times.
- Install the unit under a properly designed commercial ventilation system.
- Do not block or restrict flue or ventilation openings.
- The unit must not be installed in areas exposed to water, outdoor conditions, or excessive moisture.

Ventilation and Airflow Safety



WARNING!

Inadequate ventilation or blocked airflow can result in overheating, poor combustion, carbon monoxide exposure, or dangerous operating conditions. This unit must be installed under a properly functioning commercial ventilation system.

- Do not connect the flue outlet directly to any duct or exhaust system.
- Maintain proper clearance between the flue outlet and hood filters.
- Ensure adequate airflow to support combustion and heat removal.
- Ensure adequate make-up air is available so the exhaust system does not create strong negative pressure in the kitchen.
- Do not block the front, underside, rear flue area, or combustion air openings of the unit.
- Do not place hands, arms, or other body parts directly above the flue outlet while the unit is operating. Hot exhaust can cause burns.
- Avoid conditions that create strong drafts or downdrafts around the unit.

Cooking Operation Safety



WARNING!

Open flame, hot grates, grease, and operator contact can cause burns, fire, or unsafe operating conditions.

- Do not leave the unit unattended during operation.
- Confirm the drip tray is installed before operation.
- Monitor grease accumulation during use and empty the drip tray as needed after the unit has cooled to a safe handling temperature.
- Do not overload burners or place excessive weight on grates.
- Do not place materials directly on burners or block flame.
- Turn controls down or **OFF** when not actively cooking.
- Keep the cooking area, drip tray, and surrounding surfaces clean and free of excessive grease.

Open Flame and Cookware Safety



WARNING!

Open burners and direct flame create hazards when handling cookware or combustible materials.

- Use stable, flat-bottom cookware suitable for commercial gas burners.
- Do not use oversized cookware that blocks airflow or traps heat around control areas.
- Do not place empty cookware on high heat for extended periods.
- Do not place sealed containers on burners.
- Keep handles of pots and pans positioned safely to avoid tipping or contact.
- Do not use the unit as a storage surface.

Cleaning and Maintenance Safety



WARNING!

Improper cleaning of hot surfaces, burners, or control areas may result in burns, fire risk, equipment damage, or unsafe operation. Allow the unit to cool to a safe temperature before cleaning.

- Shut the unit down properly before beginning any cleaning or maintenance procedure.
- Allow all components to cool to a safe temperature before cleaning.
- Use only cleaning agents suitable for commercial cooking equipment and the surface being cleaned.
- Do not use corrosive, chlorine-based, or highly abrasive cleaners on stainless steel surfaces.
- Do not use ordinary steel wool, wire brushes, or carbon-steel tools on stainless steel surfaces.
- Do not spray controls, burners, pilots, gas components, or the outside of the unit with liquids or cleaning agents.
- Do not use hose-down cleaning or immerse any part of the unit in water or any other liquid.
- Ensure all components are dry and correctly installed before returning the unit to operation.

Regular cleaning and maintenance are required to ensure safe operation and prevent buildup that may affect performance.

Service and Repair Safety



WARNING!

Servicing this equipment without proper training may result in serious injury, death, gas leakage, fire, explosion, carbon monoxide exposure, or equipment damage. All service and repairs must be performed by **qualified personnel** only.

- Shut off the gas supply before performing any service or maintenance.
- Do not attempt to repair or adjust gas components without proper training.
- Do not attempt to adjust pilots, burners, regulators, or gas valves unless qualified to do so.
- Use only approved replacement parts.
- Do not operate the unit with panels removed or safety components bypassed.

Unauthorized service or modification may result in unsafe conditions and may affect warranty coverage.

IMPORTANT SAFEGUARDS

This section outlines critical requirements for safe installation, operation, and long-term use of this equipment. These safeguards supplement the Safety Information section and must be followed at all times.

Gas Connection Requirements

	WARNING!	Improper gas connection, incorrect gas type, incorrect pressure, or improper gas conversion may result in fire, explosion, carbon monoxide exposure, equipment damage, serious injury, or death.
---	-----------------	--

- Verify that the gas type shown on the rating label matches the gas supply before connection.
- This unit may be field convertible between Natural Gas and LP Gas only by **qualified service personnel** using approved components and procedures.
- Do not attempt gas conversion, regulator adjustment, burner adjustment, or pressure adjustment unless qualified to do so.
- All gas connections must be installed and tested by **qualified personnel**.
- Install a manual gas shutoff valve in an accessible location.
- Ensure gas supply pressure meets the requirements specified on the unit rating label.
- All gas connections must be leak tested prior to operation using approved methods only.
- Never use an open flame to check for gas leaks.
- Follow all gas supply pressure testing and isolation requirements during system testing.

Ventilation and Fire Code Compliance

	WARNING!	Improper ventilation may result in fire, overheating, poor combustion, carbon monoxide exposure, or unsafe operating conditions.
---	-----------------	--

- This unit must be installed under a properly designed commercial ventilation system.
- Do not connect the flue outlet directly to any duct or exhaust system.
- Maintain adequate clearance between the flue outlet and hood filters.
- Ensure adequate combustion air is available at all times.
- Do not obstruct airflow or block ventilation openings at the front, rear, underside, or flue area.
- Keep the area around the unit clear of grease buildup, food debris, packaging, towels, paper products, and combustible materials.
- Installation must comply with all applicable local fire and building codes.

Open Burner, Cookware, and Flame Safety

	WARNING!	Open flame, standing pilots, hot grates or cookware, and exposed flame can cause burns, fire, gas accumulation, equipment damage, or unsafe operation.
---	-----------------	--

- Do not operate the unit if a pilot is out, unstable, or not clearly visible.
- Do not open any burner control unless the corresponding pilot is lit and stable.
- Confirm the drip tray is installed before operating the unit.
- Confirm cast iron grates are installed and properly seated before operating the unit.
- Empty and clean the drip tray regularly, after the unit has cooled to a safe handling temperature.
- Use only cookware suitable for commercial open-burner gas equipment.
- Do not use unstable, damaged, warped, or oversized cookware.
- Do not place cookware in a way that blocks burner airflow, pilot flame, control areas, or flue discharge.
- Do not place sealed containers, aerosol cans, towels, paper products, packaging, or combustible materials on or near the unit.

Unit Disposal

	CAUTION!	Improper disposal of gas equipment may result in environmental harm, unsafe handling, or regulatory non-compliance.
---	-----------------	---

- Ensure the gas supply has been shut off and professionally disconnected before moving or disposing.
- Dispose of this equipment in accordance with applicable local regulations.
- Remove or properly handle any components that may require special disposal procedures.
- Ensure all gas connections are safely disconnected prior to disposal.
- Remove the drip tray and clean grease residue before disposal or storage awaiting disposal.
- Follow applicable guidelines for recycling or disposal of metal and other materials.

INSTALLATION

Installation must be performed by **qualified personnel** in accordance with this manual and all applicable local codes and regulations. Proper installation is essential for safe operation, correct combustion, consistent performance, and long equipment life.

Installation Responsibility and Code Compliance

	WARNING!	Improper installation may result in fire, explosion, gas leakage, carbon monoxide exposure, equipment damage, serious injury, or death.
---	-----------------	---

- Installation, including initial pilot, burner, air shutter, regulator, or pressure adjustment must be performed by **qualified personnel** only.
- Installation must comply with all applicable local codes and regulations.
- Where local codes are not available, installation must conform to:
 - Natural Gas and Propane Installation Code, CSA B149.1 (Canada)
 - National Fuel Gas Code, ANSI Z223.1 (USA)
 - The installer is responsible for verifying gas type, pressure, ventilation, and site conditions before placing the unit into service.

Pre-Installation Checklist

Before installation, confirm the following:

- The model number and gas type on the rating label match your order and the site requirements.
- The installation location meets all clearance, ventilation, and utility requirements.
- The gas supply is available and sized correctly for the equipment.
- The counter, stand, or support surface is level, stable, and capable of supporting the equipment and normal cooking load.
- All components and accessories as well as rating label are present.
- The manual gas shutoff valve and site gas connection requirements have been reviewed by qualified installation personnel before installation begins.

Do not proceed with installation if any issues are identified.

Location and Placement Requirements

	WARNING!	Improper placement may result in fire hazard, poor combustion, overheating, or unsafe operating conditions.
---	-----------------	---

- Install the unit on a stable, level surface capable of supporting the weight of the equipment and normal cooking load.
- The unit must be level front-to-back and side-to-side.
- Do not place objects between the bottom of the unit and the counter or equipment stand.
- Do not install the unit in areas exposed to water, outdoor conditions, or excessive moisture.
- Maintain required clearances from combustible and non-combustible surfaces.
- Do not block access to the gas shutoff valve.
- Do not block access to the drip tray or front pilot lighting access holes.
- Do not install where fans, open windows, supply air outlets, or strong drafts may blow directly across the pilot or burner flames.

Clearance Requirements

	WARNING!	Failure to maintain required clearances may result in fire hazard or unsafe operation. Maintain minimum clearances from combustible materials as specified below.
---	-----------------	---

Minimum clearances:

- **Combustible construction:**
 Left: 6 in (15.2 cm) Rear: 6 in (15.2 cm) Right: 6 in (15.2 cm)
- **Non-combustible construction:**
 Left: 0 in (0 cm) Rear: 0 in (0 cm) Right: 0 in (0 cm)
- **Counter surface:** Install only on a level, stable, non-combustible counter or equipment stand capable of supporting the unit and normal cooking load with all legs installed.

Always follow the rating label, certification markings, this manual, and applicable local code requirements. Where local code requires greater clearance than the rating label or this manual, follow the greater requirement.

INSTALLATION

Although this unit may be installed next to combustible construction when the required 6 in (15.2 cm) clearances are maintained, nearby walls, shelves, finishes, trim, or other materials must be suitable for the heat exposure expected in a commercial cooking environment.

Do not reduce required clearances by placing utensils, pans, towels, packaging, containers, chemicals, or combustible items beside, behind, under, or above the unit.

Ventilation and Hood Requirements



WARNING!

Inadequate ventilation may result in overheating, poor combustion, carbon monoxide exposure, or unsafe operating conditions.

- This unit must be installed under a properly designed commercial ventilation system.
- Ventilation and fire protection systems must comply with applicable local codes and NFPA 96 where adopted.
- Do not connect the unit directly to a flue or exhaust duct.
- Maintain proper clearance between the flue outlet and hood filters.
- Ensure adequate airflow for combustion and heat removal.
- Ensure adequate make-up air is available so that the exhaust system does not create excessive negative pressure in the kitchen.
- Do not block or restrict airflow at the front, rear, underside, or flue area of the unit.
- Do not allow fans, air-conditioning discharge, open windows, or cross-drafts to blow directly across the pilots or burners.

Leveling the Unit



WARNING!

Do not install or operate the unit without all legs installed. Operating the unit without legs may result in unstable conditions, improper clearance, and increased risk of fire or injury.

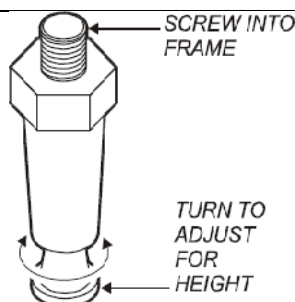

Figure A - Adjustable leg height adjustment

- Thread each leg securely into the base of the unit.
- Tighten each leg securely and confirm all legs are fully seated before placing the unit upright.
- Adjust the legs as needed to achieve proper leveling. Turn the foot clockwise or counterclockwise to raise or lower the unit as required.
- After installation, verify the unit is stable, does not rock, and is level front-to-back and side-to-side.
- Do not slide the unit with the legs installed. Lift the unit using appropriate equipment or sufficient personnel. Do not lift by legs.

Proper leveling helps maintain stable cookware placement, even heat distribution, proper drip tray fit, and consistent cooking performance.

Component Setup Before Operation

Do not operate the unit unless the cast iron grates and drip tray are correctly installed. Missing, misplaced, unstable, or incorrectly seated components may result in unstable cookware, poor combustion, food debris accumulation, overheating, equipment damage, or unsafe operation.

Before operation:

1. Confirm control knobs are installed and point to **OFF** before gas supply is opened.
2. Confirm the manual gas shutoff valve is closed.
3. Confirm all packaging, protective film, labels not intended to remain on the unit, and shipping restraints have been removed.
4. Confirm all removable cast iron grates are seated securely.
5. Confirm grates are stable and do not rock under normal cookware load.
6. Confirm the drip tray is clean, dry, fully inserted, and properly seated.
7. Confirm the front pilot lighting openings are accessible.
8. Confirm burner and pilot areas are dry and free of packaging, debris, cleaning solution, or grease.

INSTALLATION

Do not operate with wet burners, wet pilots, missing grates, missing drip tray, blocked burner openings, blocked pilot areas, or loose components.

Gas Supply Requirements



WARNING!

Incorrect gas type, improper pressure, or inadequate gas supply may result in fire, explosion, or improper operation.

- Verify that the gas type matches the rating label on the unit.
- This unit may be field convertible between Natural Gas and LP Gas only by **qualified service personnel** using approved components and procedures.
- Do not attempt gas conversion, regulator adjustment, burner adjustment, or pressure adjustment unless qualified to do so.
- Gas supply pressure must meet the requirements specified on the rating label.
- The gas supply system must be sized to provide sufficient flow for the unit at full input.
- For new installations, replacement installations, or installations with multiple gas appliances on the same line, the installer should verify that the gas meter and supply piping are adequately sized for the total connected load.
- A manual gas shutoff valve must be installed in an accessible location.
- Installation at elevations above 610 m (2,000 ft) may require verification by **qualified service personnel** to ensure proper combustion and performance.

Gas Supply Pressure Testing Requirement

- The unit and its individual manual gas shutoff valve must be disconnected from the gas supply piping system during any pressure testing of that system at test pressures in excess of 1/2 PSI (3.45 kPa).
- The unit must be isolated from the gas supply piping system by closing its individual manual gas shutoff valve during any pressure testing of the gas supply piping system at test pressures equal to or less than 1/2 PSI (3.45 kPa).

Gas Connection Procedure



WARNING!

Improper gas connection may result in fire, explosion, gas leakage, carbon monoxide exposure, equipment damage, serious injury, or death. All gas connections must be installed by **qualified personnel**.

- Connect the unit to the gas supply using approved fittings and piping.
- Ensure gas supply piping is clean and free of dirt, metal particles, debris, and excess joint compound before connection.
- Ensure a manual gas shutoff valve is installed in an accessible location.
- A sediment trap (drip leg) must be installed in the gas supply line upstream of the gas pressure regulator. The sediment trap helps prevent dirt, debris, and moisture from entering the regulator and gas components.
- Ensure the gas pressure regulator is installed correctly, in the proper flow direction, and is not positioned in a way that places stress on the gas connection.
- Ensure all threaded connections are properly sealed using materials approved for the gas type used.
- Do not apply excessive force to gas fittings, valves, regulator, or controls.
- After connection, perform leak testing before placing the unit into operation.

Gas Pressure Regulator



WARNING!

Improper installation, incorrect pressure, or missing regulator may result in fire, explosion, poor combustion, or unsafe operation.

- The supplied gas pressure regulator must be installed before the unit is placed into operation.
- The regulator must be installed in the correct orientation with gas flow arrow pointing toward the unit.
- The regulator vent opening must remain unobstructed. Do not block, plug, cover, or seal the regulator vent opening. Install the regulator so the vent is protected from grease, debris, cleaning liquids, and physical damage.
- The regulator connection size is 3/4" NPT inlet and outlet.
- The regulator is factory set for:
 - Natural Gas: 4 in. W.C. manifold pressure
 - Propane (LP): 10 in. W.C. manifold pressure
 - Maximum allowable inlet pressure to the regulator is 14 in. W.C. (1/2 PSI).
 - If incoming gas pressure exceeds this limit, a step-down regulator must be installed upstream of the unit regulator.
- Installation and any adjustment of regulator must be performed by **qualified service personnel** only.

Leak Testing Procedure



WARNING!

Gas leaks may result in fire, explosion, carbon monoxide exposure, serious injury, or death. All gas connections must be leak tested by **qualified personnel** before operation.

- After gas connection, confirm all control knobs are in the **OFF** position.
- Open the manual gas shutoff valve.
- Apply a soap-and-water solution or approved leak-detection solution to all joints and connections.
- Check for bubbles or other signs indicating a leak.
- If a leak is detected, shut off the gas supply immediately. The connection must be corrected and retested by **qualified personnel** before operation.
- Never use an open flame to check for leaks.

Pilot and Burner Verification During Installation



WARNING!

This unit does not include an automatic flame failure safety shutoff device. Gas will not be automatically shut off if a pilot flame goes out. Opening a burner control without a stable pilot flame may allow unburned gas to accumulate and may result in fire, explosion, serious injury, or death.

Pilot and burner verification must be performed by qualified installation or service personnel before the unit is released for operation.

- Confirm the ventilation hood is operating before lighting.
- Confirm all control knobs are in the **OFF** position before opening the manual gas shutoff valve.
- Confirm each pilot lights through the front pilot lighting access opening only.
- Confirm each pilot flame is stable.
- Confirm one pilot serves each burner pair.
- Confirm the left knob controls the rear burner.
- Confirm the right knob controls the front burner.
- Confirm each burner ignites promptly from its corresponding pilot.
- Confirm burner flames are stable and predominantly blue.
- Confirm burners shut off properly when control knobs are turned **OFF**.
- Confirm pilots extinguish when the manual gas shutoff valve is closed during complete shutdown.
- If a pilot will not light, will not remain lit, does not reliably ignite its burner pair, or flame behavior is abnormal, shut down the unit by turning all control knobs **OFF** and closing the manual gas shutoff valve. Do not release the unit for operation until the condition has been corrected by **qualified personnel**.

Do not instruct operators to adjust pilots, burners, air shutters, regulators, valves, or gas components.

Final Installation Checks

Before opening the gas supply and lighting the unit, confirm the following:

- The unit is installed in the correct location and meets all clearance requirements.
- The unit is level front-to-back and side-to-side.
- Legs are properly installed and secured.
- The counter or support surface is stable and suitable for the unit and normal cooking load.
- The gas type matches the rating label.
- The gas supply is connected securely and has been leak tested.
- The gas pressure regulator is installed correctly and oriented in the direction of gas flow.
- The regulator vent opening is unobstructed and protected from grease, debris, cleaning liquids, and physical damage.
- The manual gas shutoff valve is accessible to the operator.
- The ventilation system is installed, operational, and unobstructed.
- The flue area is not blocked and has proper clearance to hood filters.
- The drip tray is installed and properly seated.
- Cast iron grates are installed correctly and seated securely.
- Front pilot lighting openings are accessible.
- All protective films, packaging, and shipping materials have been removed.
- All control knobs are in the **OFF** position before opening the gas supply.

Do not attempt to light or operate the unit until all installation checks have been completed.

Installation Responsibility and Warranty Conditions

Installation must be performed in accordance with this manual and all applicable local codes and regulations. Improper installation may result in reduced performance, equipment damage, unsafe operating conditions, fire hazard, carbon monoxide exposure, or affected warranty coverage. The following conditions are not covered under warranty:

- Damage resulting from improper unpacking, handling, or installation.
- Problems caused by installation with the wrong gas type, improper gas conversion, or gas supply pressure not matching the rating label.
- Problems caused by improper gas connection, failure to leak test, use of non-approved gas supply components, failure to install the supplied regulator correctly, or failure to install an accessible manual gas shutoff valve where required.
- Performance or safety issues caused by inadequate ventilation, restricted combustion air, blocked flue discharge, improper hood installation, insufficient make-up air, strong drafts, or failure to maintain required clearances.
- Damage, instability, or performance issues caused by improper leveling or failure to install legs correctly.
- Problems caused by installation in unsuitable environments, including outdoor installation, water exposure, excessive moisture, or other conditions inconsistent with this manual.
- Damage or unsafe conditions resulting from unauthorized modification, non-approved parts, improper service, or unauthorized gas system adjustment.
- Problems caused by missing, misplaced, blocked, damaged, wet, or incorrectly installed cast iron grates, burners, pilots, control knobs, regulator, or drip tray.

OPERATION

This section provides instructions for safe startup, operation, and shutdown of NORIOTA gas countertop hot plates. Read and follow all instructions before operating the unit.

Improper operation may result in burns, fire hazard, gas accumulation, delayed ignition, poor combustion, carbon monoxide exposure, unstable flame, equipment damage, or unsafe conditions.

Control System Overview

NORIOTA gas countertop hot plates use manual gas controls and standing pilots.

- Each burner is controlled by an individual manual gas control knob.
- Each burner pair is served by one standing pilot.
- The pilot is located between the two control knobs for the burner pair.
- The **left knob** controls the rear burner.
- The **right knob** controls the front burner.
- Burner output is adjusted manually from **OFF** to maximum flame.
- Heat output is not thermostat-controlled and will vary based on flame setting, preheat time, cookware size, cookware material, food load, ventilation, and operating conditions.
- Operator technique and heat management are required for consistent cooking results.

This unit does not include an automatic flame failure safety shutoff device. Operators must confirm the pilot flame is lit and stable before turning **ON** any burner control.

How the Hot Plate Works

Understanding how the unit operates will improve performance and reduce operator error.

- Each burner heats cookware placed on the cast iron grate above it.
- Larger units have multiple independently controlled burners that can be used for separate cooking tasks.
- Each burner pair shares one standing pilot positioned between the two burners.
- Once the pilot is lit and stable, each burner in that pair can be turned on using its own control knob.
- Open burners provide direct flame to cookware. Heat transfer depends heavily on flame setting, cookware type, cookware size, cookware condition, and loading pattern.
- Food spills, boil-over, grease, and debris may fall through the grates and collect in the drip tray.
- Cooking performance depends on preheat time, flame setting, cookware selection, batch size, food load, ventilation, and cleaning condition.

Do not operate the hot plate unless all required cast iron grates and the drip tray are installed correctly.

Before First Use



CAUTION!

Failure to properly prepare the unit before first use may result in poor cooking performance, excessive smoke, odor, unstable cookware, blocked airflow, equipment damage, or unsafe operation.

Before using the unit for food preparation:

1. Confirm installation is complete and all installation checks have been performed.
2. Confirm the ventilation hood is operating.
3. Remove all packaging materials, protective film, labels not intended to remain on the unit, and shipping restraints.
4. Clean the cooking grates and removable components with warm water and mild detergent, then rinse and dry thoroughly.
5. Confirm the drip tray is installed and properly seated.
6. Confirm cast iron grates are installed and seated correctly.
7. Confirm burners, pilot areas, control areas, and drip tray are dry and free of packaging, debris, grease, or cleaning solution.
8. Perform the initial burn-off procedure before cooking food.

Do not cook food on the hot plate until the unit and cast iron grates have been properly cleaned and the initial burn-off has been completed.

Initial Burn-Off Procedure

During first use, it is normal for some odor or light smoke to occur as manufacturing residue and protective oils burn off. Confirm the ventilation hood is operating.

1. Confirm all grates and drip tray are installed correctly.

OPERATION

2. Light the pilots according to the Lighting the Pilots section.
3. Turn burner controls to the maximum setting.
4. Allow the unit to burn off for at least 15 minutes before first cooking.
5. After burn-off, turn all burner controls **OFF**, close the manual gas shutoff valve, and allow the unit to cool as needed before wiping or handling components.

Some smoke or odor may occur during first use. This is normal during initial burn-off. If the odor smells like gas, turn all control knobs **OFF**, close the manual gas shutoff valve if safe to do so, and follow site gas emergency procedures.

Lighting the Pilots



WARNING!

Improper lighting may result in fire, explosion, gas accumulation, burns, or unsafe operation. If ignition does not occur, turn all controls **OFF**, shut off the manual gas shutoff valve, wait at least 5 minutes, and retry only after gas has dissipated. Do not allow unburned gas to accumulate.

This unit is equipped with standing pilots. Each burner pair has one pilot. The pilots must be lit immediately after the manual gas shutoff valve is opened. There is no automatic flame failure safety shutoff device.

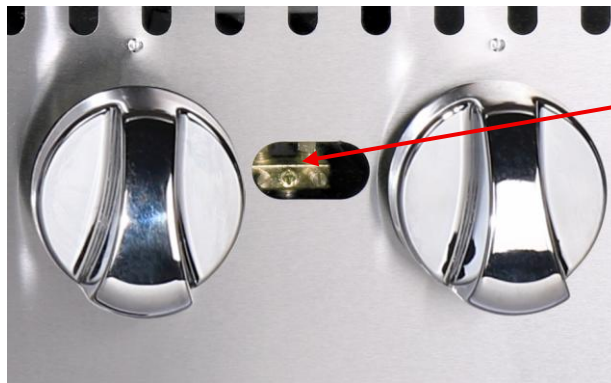

Pilot lighting
access hole
and pilot
flame area

Figure B – Pilot lighting location, front access

1. Confirm the ventilation hood is operating.
2. Confirm all control knobs are in the **OFF** position.
3. Confirm the manual gas shutoff valve is closed.
4. Wait at least 5 minutes to allow any accumulated gas to dissipate.
5. Open the manual gas shutoff valve.
6. Using a suitable long ignition source, light each pilot through the front pilot lighting access opening.
7. When the pilot flame is established, remove the ignition source.
8. Repeat for each pilot as required by the model.
9. Verify that each pilot flame is lit and stable before turning **ON** any burner control.
10. After all required pilots are lit and stable, turn the applicable burner control knob to the desired setting and verify that the burner ignites promptly.
11. If a burner does not ignite within a few seconds, turn all control knobs **OFF**, close the manual gas shutoff valve, wait at least 5 minutes, and retry only after gas has dissipated.
12. If the pilot will not light, will not remain lit, or burner ignition remains delayed or unstable, turn all control knobs **OFF**, close the manual gas shutoff valve, discontinue use, and contact **qualified service personnel**.

During initial startup or after extended shutdown, several lighting attempts may be required because air may be present in the gas line. Do not allow unburned gas to accumulate.

Do not remove cast iron grates to light pilots from above. Pilots must be lit through the front pilot lighting access openings only.

Flame Appearance

- Burner flames should be steady and predominantly blue.
- Yellow, orange, lifting, rolling, unstable, noisy, or sooty flames may indicate poor combustion, dirty burners, incorrect gas supply conditions, blocked airflow, improper ventilation, or a service issue.

If abnormal flame conditions are observed, turn all control knobs **OFF**, close the manual gas shutoff valve, refer to the **Troubleshooting Guide**, or contact **qualified service personnel**.

Pilot Flame Adjustment



WARNING!

Pilot adjustment must be performed by **qualified service personnel** only. Improper pilot adjustment may result in delayed ignition, unstable flame, gas accumulation, poor combustion, or unsafe operation.

Pilot flames are factory adjusted. If a pilot flame is too small to reliably ignite the burner, too large, unstable, or repeatedly goes out, shut down the unit and contact **qualified service personnel**. Do not remove the front panel or attempt to adjust pilot flame unless qualified to do so.

Burner Adjustment



WARNING!

Burner adjustment must be performed by **qualified service personnel** only. Improper burner adjustment may result in yellow flame, lifting flame, poor combustion, carbon monoxide exposure, fire hazard, or unsafe operation.

Burners are factory adjusted for the gas type shown on the rating label. If burner flames appear yellow, lifting, unstable, noisy, sooty, or do not ignite promptly from the pilot, shut down the unit, close the manual gas shutoff valve, and contact **qualified service personnel**.

Do not remove the front panel, adjust air shutters, adjust mixing rings, change orifices, or modify gas components unless qualified to do so.

Burner Controls



Figure B – Burner control knobs in OFF position

Control Knob Position

Indicator Points UP:
OFF

Indicator Points LEFT:
ON/MAX Flame

Indicator Between UP
and LEFT:
Intermediate Flame

Each burner is controlled by an individual manual gas valve. Burner output is adjusted by rotating the control knob between the **OFF** position and the maximum flame setting.

Control mapping:

- One pilot serves each burner pair.
- The pilot is located between the two control knobs.
- **Left knob** controls the rear burner.
- **Right knob** controls the front burner.

Control Positions

- **OFF** - Knob in the upward position
- **ON / MAX** - Knob rotated fully to the left (counterclockwise)
- **Intermediate Settings** - Any position between **OFF** and **MAX** provides a proportional flame level

Lighting and Burner Operation

1. Confirm the manual gas shutoff valve is open and the pilot flame is lit and stable.
2. Select the desired burner control knob.
3. Turn the knob counterclockwise (to the left) from **OFF** toward the **ON / MAX** position.
4. Continue turning until the burner ignites.
5. Once ignition is confirmed, adjust the flame to the desired level.

Flame Adjustment

- Flame level is continuously adjustable between **OFF** and **MAX**.
- Use higher settings for boiling, fast recovery, sautéing, and heavy cooking loads.
- Reduce flame for simmering, finishing, lighter cooking loads, or idle periods.

Important Operating Notes

- Do not turn **ON** a burner control unless the corresponding pilot flame is lit and stable.
- If burner does not ignite within a few seconds, turn all burner controls **OFF**, close the manual gas shutoff valve, wait at least 5 minutes, and retry only after gas has dissipated.
- Do not force the control knob beyond its normal rotation range.
- Always return the control knob to **OFF** when the burner is not in use.

OPERATION

- If any pilot flame goes out during operation, shut down the unit immediately by turning all control knobs **OFF** and closing the manual gas shutoff valve. Do not operate any burners until the pilot has been safely relit by following **Lighting the Pilots** section, and is stable.

Startup Procedure



WARNING!

Improper startup may result in fire, gas accumulation, burns, poor combustion, or unsafe operation. Do not operate the unit unless installation is complete, ventilation is operating, pilots are lit, and the drip tray is installed.

Before startup:

1. Confirm the unit is installed correctly and all installation checks are complete.
2. Confirm the ventilation hood is operating.
3. Confirm the unit is level and stable.
4. Confirm cast iron grates and drip tray are installed and seated correctly.
5. Confirm the cooking area is clean and free of excessive grease, food debris, packaging, towels, utensils, or other combustible materials.
6. Confirm all control knobs are in the **OFF** position.
7. Follow the **Lighting the Pilots** section.
8. Confirm all required pilots are lit and stable.
9. Open burner controls only after the corresponding pilots are lit and stable.
10. Preheat the unit before loading food.

Typical preheat time will vary depending on model size, gas supply, ventilation, ambient conditions, and desired cooking result. Do not begin cooking until the unit has reached the desired operating condition.

If ignition does not occur within a few seconds, turn all burner controls **OFF**, close the manual gas shutoff valve, wait at least 5 minutes, and retry only after gas has dissipated. If ignition continues to fail, discontinue use of the unit and contact **qualified service personnel**.

Normal Operation

During normal operation, the hot plate uses open gas burners to heat cookware placed on removable cast iron grates. Cooking performance depends on preheat time, flame setting, cookware size, cookware material, cookware condition, food load, batch size, ventilation, and operator technique.

The following conditions are normal:

- Standing pilots remain lit during operation.
- Burners ignite from the pilot flame when controls are turned on.
- Heat variation occurs across cooking zones.
- Recovery time is required after heavy loading or when using large cookware.
- Light smoke or odor may occur during first use or burn-off.
- Cast iron grates may darken with normal use.
- Grease, food debris, and liquid residue may collect in the drip tray during operation.
- Stainless steel near hot cooking areas may discolor from repeated heat exposure.

The hot plate must be monitored during use. Adjust controls, cookware placement, batch size, and cleaning frequency as needed to maintain safe operation and consistent cooking results. Do not leave the hot plate unattended during operation.

Heat Zone and Cookware Management

Each burner heats a specific cooking zone. Wider hot plates have multiple zones that can be used for different cooking tasks. Good heat zone and cookware management is critical for safe operation and consistent results.

Heat Zones

- Use higher flame settings for boiling, fast recovery, sautéing, and high-volume cooking.
- Use medium flame settings for general cooking.
- Use lower flame settings for simmering, finishing, lighter cooking loads, or short holding periods.
- Avoid loading all burners with cold, heavy cookware at one time unless the unit has been properly preheated and recovery time is expected.
- Use a consistent loading pattern for repeatable cooking results.
- Turn unused burners **OFF** when practical.
- Reduce flame during idle periods.

Cookware Use

- Use stable, flat-bottom cookware suitable for commercial gas burners.
- Match cookware size to the burner and grate area whenever practical.

OPERATION

- Do not use cookware that is unstable, warped, cracked, or likely to tip.
- Do not use oversized cookware that blocks burner airflow, pilot areas, control areas, or flue discharge.
- Do not allow pot handles to extend into aisles, over adjacent burners, or beyond the edge of the work area where they may be bumped.
- Do not place sealed containers on burners.
- Do not heat empty cookware at high flame for extended periods.
- Do not place foil, sheet pans, trays, or other objects over the grates to trap heat or cover burners.

Hot Plate Operation Best Practices

Proper operating practices are essential for safe operation, consistent food quality, and long equipment life.

Before Cooking

- Confirm ventilation is operating.
- Confirm the drip tray is installed and properly seated.
- Confirm grates are installed and seated securely.
- Confirm pilots are lit and stable.
- Preheat the unit before loading cookware.
- Select cookware suitable for the cooking task.
- Use the correct burner and flame setting for the cooking task.

During Cooking

- Do not leave the unit unattended.
- Do not overcrowd the cooking surface with cookware.
- Do not block burner airflow, pilot areas, or flue discharge.
- Do not allow boil-over, grease, food debris, or liquid residue to accumulate.
- Monitor the drip tray and do not allow overflow.
- Reduce heat during idle periods.
- Turn unused burner zones **OFF** when practical.
- Keep towels, packaging, paper products, utensils, and combustible materials away from hot surfaces and open flame.
- Keep hands, sleeves, aprons, and loose clothing away from burner flames and hot cookware.

After Cooking

- Turn all burner controls **OFF** when cooking is complete.
- Follow **Complete Shutdown** procedure when the unit will not remain attended.
- Allow components and grease to cool before cleaning.
- Empty and clean the drip tray once safe to handle.
- Clean grates, drip tray, and accessible surfaces according to the **Cleaning and Maintenance** section.

Abnormal Operating Conditions

Stop using the unit, turn all control knobs to **OFF**, close manual gas shutoff valve, and refer to the **Troubleshooting Guide** or contact **qualified service personnel** if any of the following conditions occur:

- gas odor
- pilot will not light or will not remain lit
- pilot flame goes out during operation or is not stable before burner use
- burner does not ignite within a few seconds
- delayed ignition or popping sound
- yellow, lifting, rolling, unstable, noisy, or sooty flame
- excessive smoke not related to normal cooking or first-use burn-off
- cookware is unstable or unsafe on the grate
- grates are missing, damaged, unstable, or incorrectly installed
- drip tray is missing, full, damaged, or incorrectly installed
- control knob sticks, binds, feels loose, or does not shut off normally
- unusual vibration, noise, or visible damage
- water, cleaning solution, or grease has entered burner, pilot, control, or gas component areas
- the unit has been moved, dropped, damaged, or exposed to excessive water
- ventilation is not operating correctly
- strong drafts affect pilot or burner flame

If any pilot flame goes out, shut down the unit immediately by turning all knobs to **OFF** and closing the manual gas valve. Do not operate any burners until the pilot has been safely relit and is stable. Wait at least 5 minutes before attempting to relight. This waiting period allows unburned gas to dissipate. Do not continue operation if

unsafe conditions are present.

Shutdown Procedure



Do not begin cleaning, servicing, moving cookware, removing grates, handling the drip tray, or touching burner areas until the unit has been shut down and cooled to a safe temperature. Hot grates, burners, cookware, drip tray contents, and metal surfaces can cause severe burns.

The unit may be shut down in one of two ways depending on how long it will remain out of use:

- **Standby shutdown** - for short idle periods when the unit will remain attended and may be returned to operation shortly
- **Complete shutdown** - for end of day, cleaning, maintenance, extended idle periods, or whenever the unit is not intended to remain ready for immediate use

Standby Shutdown

Use standby shutdown only for short periods when the unit will remain attended.

1. Turn all burner control knobs to the **OFF** position.
2. Confirm that all burners are off and that only pilots remain lit.
3. Confirm no food, grease buildup, utensils, towels, packaging, or combustible materials are left on or near the cooking surface.
4. Monitor the unit while pilots remain lit.

In standby mode, pilots remain lit but burners will not operate until the controls are turned on again.

Complete Shutdown

Use complete shutdown for end of day, before cleaning, during maintenance, after pilot outage, during abnormal operation, or whenever the unit will not be used for an extended period.

1. Turn all burner control knobs to the **OFF** position.
2. Confirm all main burners are off.
3. Shut off the manual gas shutoff valve.
4. Confirm that all burners are off and that pilot flames are extinguished.
5. Allow grates, burners, drip tray, flue area, cookware, and metal surfaces to cool to a safe temperature.
6. Empty and clean the drip tray once it can be handled safely.
7. Clean the unit according to the **Cleaning and Maintenance** section.

Power Outage Shutdown



If power loss prevents proper ventilation, turn all controls **OFF**, close the manual gas shutoff valve, and do not resume operation until required ventilation and normal operating conditions have been restored. Do not use the unit during a power outage if the ventilation hood or required building systems are not operating.

Gas Conversion



Improper gas conversion may result in fire, explosion, carbon monoxide exposure, poor combustion, equipment damage, serious injury, or death.

This unit may be configured for use with Natural Gas or LP Gas as indicated on the rating label. Gas conversion must be performed only by **qualified service personnel** using approved components and procedures.

- Do not attempt to convert the gas type of this unit.
- Do not attempt to change orifice sizes, adjust regulators, modify burners, adjust pilots, or alter gas components.
- Gas conversion requires specialized knowledge, tools, and verified procedures.
- Incorrect conversion may result in unstable flame, poor combustion, overheating, delayed ignition, gas leakage, or unsafe operation.
- After conversion, gas type, manifold pressure, burner operation, pilot operation, and leak testing must be verified by **qualified service personnel**.

Detailed gas conversion instructions are intentionally not included in this manual. Conversion procedures are provided separately to qualified service technicians.

If gas conversion is required, contact NORIOTA or a **qualified service provider** to obtain the correct instructions and components.

CLEANING AND MAINTENANCE

Regular cleaning and preventive maintenance are essential to maintaining safe operation, consistent cooking performance, food quality, and long equipment life. Accumulation of grease, food debris, carbonized residue, boil-over, or cleaning chemical residue may result in uneven heating, excessive smoke, unstable flame, blocked airflow, corrosion, increased fire risk, or unnecessary service calls.

Only routine cleaning and basic operation should be performed by the operator. All adjustments, repairs, and internal servicing must be performed by **qualified service personnel**.

Cleaning and Maintenance Safety



WARNING!

Improper cleaning of hot surfaces, burners, pilots, controls, or gas components may result in burns, fire risk, equipment damage, gas accumulation, poor combustion, or unsafe operation. Shut the unit down properly and allow all surfaces to cool to a safe temperature before cleaning or maintenance.



CAUTION!

Do not use water, hose-down cleaning, pressure washing, excessive moisture, or spray cleaning methods on the hot plate cabinet, burner area, pilot area, controls, gas components, or ventilation openings. Water intrusion may damage components, affect ignition, create unsafe combustion, or cause service issues.

- Shut the unit down in accordance with the **Complete Shutdown** Procedure before cleaning.
- Allow grates, burners, drip tray, flue area, and exterior surfaces to cool to a safe handling temperature.
- Use appropriate protective equipment when handling warm grates, warm drip tray, grease, cookware, or cleaning tools.
- Apply cleaning solution to a cloth, pad, or approved tool. Do not spray directly into control, burner, pilot, or ventilation areas.
- Keep all gas components dry.
- Confirm all cleaned areas are dry before returning the unit to operation.
- If water, cleaner, or grease enters burner, pilot, control, or gas component areas, discontinue use until the condition has been corrected by **qualified service personnel**.

General Maintenance Guidance

Grease, food debris, boil-over, and carbon buildup are major causes of poor performance. They can increase smoke, affect flame stability, reduce heat consistency, interfere with ignition, create odor, attract pests, and shorten the life of the unit.

Routine cleaning and preventive maintenance help reduce fire risk, improve cooking consistency, reduce smoke and odor, support stable burner ignition and flame appearance, reduce corrosion risk, preserve stainless steel appearance, reduce unnecessary service calls, and extend equipment life.

Do not:

- use corrosive, chlorine-based, sulfate-based, sulfide-based, or harsh cleaners not intended for commercial cooking equipment
- use ordinary steel wool, carbon-steel wire brushes, files, or carbon-steel tools on stainless steel surfaces
- use tools that gouge, bend, crack, or damage components
- strike components with utensils or tools
- pour water onto hot grates, burners, pilots, grease areas, or any other surfaces
- spray water, cleaners, or sanitizers into burners, pilots, controls, regulator, gas components, or ventilation openings
- immerse the unit in water or any other liquid
- operate the unit with wet burners, wet pilots, wet gas components, missing drip tray, missing grates, or incorrectly installed removable components
- bypass shutdown, cooling, drying, or reassembly procedures

Cleaning frequency depends on cooking volume, grease load, food type, spills, ventilation conditions, and site practices. Heavy-use operations require more frequent cleaning.

During-Use Cleaning

Cleaning during operation helps maintain cooking consistency and reduces end-of-day buildup.

- Wipe spills from safe, accessible exterior surfaces only when it can be done without burn risk.
- Do not reach into burner, pilot, or grate areas while the unit is operating.
- Do not remove grates while burners or pilots are operating.
- Do not remove the drip tray while the unit is operating or while the tray is hot.
- Monitor boil-over, grease, and food debris.
- Reduce heat if boil-over or excessive spillage occurs.
- Monitor the drip tray and do not allow overflow.
- Reduce heat during idle periods.
- Do not leave burners at maximum flame when not actively cooking.
- Keep towels, utensils, packaging, paper products, and combustible materials away from cooking areas.

End-of-Day Cleaning

End-of-day cleaning should remove food debris, grease, boil-over residue, and light carbon buildup before it hardens and becomes difficult to remove.

1. Turn all burner controls **OFF**.
2. Close the manual gas shutoff valve.
3. Allow the hot plate, grates, burners, drip tray, and metal surfaces to cool to a safe handling temperature.
4. Remove cookware and loose debris from the cooking area.
5. Remove cast iron grates after they are cool enough to handle safely.
6. Brush or wipe food debris and light carbon buildup from the grates.
7. Remove and clean the drip tray.
8. Wipe accessible interior ledges and areas where grease, crumbs, or debris have accumulated.
9. Clean exterior stainless steel surfaces.
10. Confirm all parts are dry.
11. Reinstall all required components before the next use.

Do not return the unit to operation unless all required components are fully installed and dry.

Cast Iron Grate Cleaning

Cast iron grates are exposed to high heat, cookware movement, grease, food debris, boil-over, and carbon buildup. Regular cleaning is required for safe operation and consistent cooking results.

Daily or as needed:

1. Confirm all burner controls are set to **OFF**, the manual gas shutoff valve is closed, and the grates have cooled to a safe handling temperature.
2. Remove the grates carefully. Grates are heavy. Use appropriate protective equipment.
3. Brush or scrape loose food debris and carbonized buildup from the top and bottom surfaces of the grates.
4. Wash grates with warm water and mild detergent if needed.
5. Rinse thoroughly.
6. Dry completely before reinstalling.
7. Lightly coat cast iron grates with cooking oil after cleaning if needed to help reduce rust and sticking.
8. Reinstall grates securely in the desired approved position.

Do not reinstall wet grates. Moisture can cause rust and may create steam or splatter when the unit is heated.

Drip Tray Cleaning



WARNING!

Hot grease can cause severe burns. Use extreme care when handling the drip tray. Do not remove, empty, or clean the drip tray while grease is at an unsafe temperature.

The drip tray catches grease, food debris, boil-over, crumbs, and liquid residue that fall through the cooking area. It must be cleaned regularly to reduce fire risk, smoke, odor, sanitation issues, pest risk, and overflow.

During operation:

- Monitor accumulation in the drip tray.
- Do not allow grease, food debris, or liquid residue to overflow.
- Increase monitoring during high-volume cooking or heavy boil-over conditions.
- If excessive accumulation is observed, shut down the unit and allow it to cool before removing the tray.

Daily or more often during heavy use:

1. Confirm the unit has been completely shut down.
2. Confirm the manual gas shutoff valve is closed.
3. Allow grease and the tray to cool to a safe handling temperature.

CLEANING AND MAINTENANCE

4. Carefully remove the drip tray.
5. Empty grease, food debris, and liquid residue according to site procedures and applicable regulations.
6. Wash the drip tray using warm water and mild detergent.
7. Rinse and dry thoroughly.
8. Inspect the drip tray for damage, warping, excessive corrosion, or improper fit.
9. Reinstall the drip tray fully before returning the unit to operation.

Do not operate the unit unless the drip tray is fully installed and properly seated.

Exterior and Stainless Steel Cleaning

Exterior cabinet surfaces should be kept clean and free of grease, food residue, and soil accumulation. If routine cleaning is neglected, grease and residue can bake onto hot surfaces and become much harder to remove.



CAUTION!

Improper cleaning tools or chemicals may damage stainless steel surfaces and increase future staining or corrosion risk.

Cleaning Procedure

- Use warm water and a mild soap or detergent on a soft cloth.
- Rinse with clean water and dry thoroughly.
- Do not allow water, cleaner, or sanitizer to remain on stainless steel surfaces.
- For grease or stubborn residue, use a non-abrasive cleaner suitable for stainless steel.
- Always rub in the direction of the stainless steel grain.
- Dry with a soft cloth after cleaning.

Do not use:

- carbon-steel wire brushes, scrapers, files, or other carbon-steel tools
- ordinary steel wool or abrasive methods that scratch the finish
- circular scrubbing patterns on polished stainless steel surfaces
- chlorine-based, iodide-based, ammonia-based, bromine-based, or corrosive cleaners unless specifically approved for the surface

Darkened heat-tint areas on stainless steel may occur from repeated exposure to heat. This may be normal near hot cooking areas, but these areas should be cleaned using appropriate stainless-safe methods only.

Burner and Pilot Area Inspection



WARNING!

Burner, pilot, air shutter, regulator, valve, and gas component adjustment must be performed by **qualified service personnel** only. Do not remove panels or disassemble gas components unless qualified to do so.

Burner and pilot areas should be kept free of grease, lint, and debris to support proper ignition, stable flame, and safe operation.

Operator-level inspection:

- Inspect only when the unit is **OFF**, cool, and the manual gas shutoff valve is closed.
- Check accessible areas for grease buildup, loose debris, or signs of obstruction.
- Keep the front, underside, rear flue area, and combustion air openings clear.
- Do not spray water or cleaning chemicals into burner or pilot areas.
- Do not remove the front panel for cleaning unless qualified to do so.
- Do not attempt to clean burner orifices, adjust pilots, adjust air shutters, or tune burners.

Contact **qualified service personnel** if:

- pilot flame is weak, unstable, too large, or repeatedly goes out
- burner flame is yellow, lifting, rolling, noisy, delayed, or sooty
- ignition is delayed or inconsistent
- burner performance changes after cleaning
- grease or cleaning solution enters burner, pilot, control, or gas component areas
- burner ports appear blocked and cannot be safely cleaned through normal operator-level cleaning

Flue and Ventilation Area Inspection

The flue area should be inspected regularly for obstruction, grease, or abnormal heat exposure. Blocked flue discharge or restricted airflow can affect safety, combustion, and performance.

- Inspect only when the unit is **OFF**, cool, and the manual gas shutoff valve is closed.
- Check for obstruction, grease buildup, debris, corrosion, or signs of abnormal heat exposure.
- Do not place objects on, over, behind, or around the flue outlet.
- Do not block the front, underside, rear, or flue area of the unit.
- Do not operate the unit if the flue area is blocked.
- Verify the ventilation hood is clean, operating, and unobstructed according to site procedures.

CLEANING AND MAINTENANCE

If flame behavior changes when the ventilation system operates, the issue may be related to kitchen airflow, make-up air, or strong drafts. Contact **qualified service** or a **ventilation professional** if the condition persists.

Reassembly and Drying

After cleaning or maintenance:

- Confirm cast iron grates are clean, dry, and seated securely.
- Confirm the drip tray is clean, dry, fully installed, and properly seated.
- Confirm burner, pilot, control, and gas component areas are dry.
- Confirm no cleaning tools, towels, packaging, or combustible materials remain on or near the unit.
- Confirm all control knobs are in the **OFF** position before opening the manual gas shutoff valve.
- Confirm the unit is stable and grates do not rock or shift.

Do not operate the unit with wet components, missing drip tray, missing grates, residual cleaner, or water in burner, pilot, control, or gas component areas.

Area Around and Beneath the Unit

Grease and debris accumulation around the unit increases sanitation problems, cleaning difficulty, pest risk, and fire risk.

- Clean around the unit daily.
- Clean behind and beneath the unit on a scheduled basis appropriate to the operation.
- Keep the surrounding area free of grease accumulation, food debris, packaging, towels, paper products, and combustible clutter.
- Do not store items on, behind, beneath, or against the unit.
- Do not place objects between the bottom of the unit and the counter or equipment stand.

Preventive Maintenance and Service Boundary

Preventive maintenance is a documented program of routine checks and cleaning intended to support safe, sanitary, and efficient equipment operation.

Operators may perform:

- during-use spill monitoring and debris removal
- daily grate cleaning
- light grate oiling for rust prevention
- drip tray removal and cleaning
- exterior stainless steel cleaning
- basic visual inspection of surface condition, grease buildup, flame appearance, airflow obstruction, and flue obstruction
- basic observation of heat consistency and flare-up behaviour during normal cooking

Qualified service personnel should perform:

- pilot adjustment
- burner tuning or air shutter adjustment
- regulator adjustment or replacement
- gas valve adjustment, servicing, or replacement
- burner orifice inspection, replacement, or cleaning beyond routine external access
- internal gas system inspection
- pressure verification and adjustment
- gas conversion between Natural Gas and LP Gas
- repair of leaking, stripped, damaged, unstable, or unsafe components
- service involving panel removal or internal disassembly

Improper servicing may result in unsafe operation, equipment damage, reduced performance, gas leakage, poor combustion, carbon monoxide exposure, or affected warranty coverage.

Recommended Maintenance Schedule

Use the schedule below as a baseline. Increase frequency as required by daily volume, grease load, boil-over, product type, spills, debris, flame behavior, or site conditions.

Task	Recommended Frequency
Monitor boil-over, grease, and food debris	During operation
Monitor drip tray accumulation	During operation
Reduce idle heat when not actively cooking	During operation

TROUBLESHOOTING GUIDE

If the unit does not appear to be operating correctly, review the **Operation**, **Shutdown Procedure**, and **Cleaning and Maintenance** sections first. Many issues are caused by startup sequence, gas supply, ventilation, pilot condition, cookware load, drip tray condition, or cleaning needs and can often be corrected without service.

Use the guide below to identify common symptoms, likely causes, and recommended corrective actions. If the issue persists after completing the recommended steps, discontinue use and contact **qualified service personnel**.

	WARNING!	<p>If the issue involves gas odor, visible leakage, unstable flame, delayed ignition, excessive flare-ups, uncontrolled flames, overheating, or any other unsafe condition, turn all control knobs OFF, close the manual gas shutoff valve, and do not resume operation until the problem has been corrected.</p>
---	----------	--

	WARNING!	<p>Shut the unit down by turning all control knobs OFF and closing the manual gas shutoff valve. Allow the unit to cool before inspection, cleaning, or maintenance. Do not attempt to adjust, repair, disassemble, or modify gas, burner, pilot, regulator, or control components unless qualified to do so.</p>
---	----------	--

Before Calling for Service

Before troubleshooting specific issues, confirm the following:

- The gas supply is turned on.
- The manual gas shutoff valve is open during operation and accessible for emergency shutdown.
- The gas type matches the rating label.
- The gas pressure regulator is installed and oriented correctly.
- All control knobs are in the correct position.
- Each pilot is lit and stable before the corresponding burner control is opened.
- Burner controls have not been opened unless the corresponding pilot flame is lit and stable.
- Burner and pilot areas are dry and have not been exposed to water, cleaner, or grease.
- The ventilation hood is operating and unobstructed.
- Make-up air is available and strong drafts are not affecting the unit.
- The unit is level front-to-back and side-to-side.
- Grates are installed and seated correctly.
- The drip tray is installed, properly seated, and not full.
- The cooking area is free of excessive grease, food debris, carbon buildup, and packaging materials.
- Cookware is stable, properly sized, and not blocking burner airflow.
- If other gas appliances connected to the same gas supply are also not operating correctly, the issue may be related to the building gas supply rather than the unit.

Many apparent equipment problems are resolved by correcting one of the above conditions.

Symptom	Possible Cause	Corrective Action
Gas Odor and Unsafe Gas Conditions		
Gas odor is present	Gas leak or unsafe gas condition	Turn all control knobs OFF , close the manual gas shutoff valve if safe, do not relight, evacuate as required, and follow site gas emergency procedures.
Pilot and Ignition		
Pilot will not light	Manual gas shutoff valve is closed	Open the manual gas shutoff valve only when ready to light pilots immediately.
	Gas supply is unavailable	Turn all control knobs OFF , close the manual gas shutoff valve, verify gas supply is available, and contact the gas supplier or qualified service personnel if needed.
	Air in gas line during first startup or after extended shutdown	Turn all control knobs OFF , close the manual gas shutoff valve, wait at least 5 minutes, then repeat the Lighting the Pilots procedure.
	Ignition source is not reaching pilot	Use a suitable long ignition source through the front pilot lighting access opening only. Do not light from above.
	Pilot opening, pilot tube, or pilot assembly is blocked, wet, damaged, or not operating correctly	Turn all control knobs OFF , close the manual gas shutoff valve, discontinue use, and contact qualified service personnel .

TROUBLESHOOTING GUIDE

Symptom	Possible Cause	Corrective Action
Pilot lights but will not stay lit	Pilot flame is weak or unstable	Turn all control knobs OFF , close the manual gas shutoff valve, wait at least 5 minutes, and relight. If the problem continues, contact qualified service personnel .
	Draft, hood imbalance, or make-up air issue	Turn all control knobs OFF , close the manual gas shutoff valve, verify ventilation, and eliminate strong drafts where possible. If the problem continues, contact qualified service personnel or a ventilation professional.
Pilot goes out during operation	Draft, gas supply interruption, dirty pilot area, or pilot adjustment issue	Turn all control knobs OFF , close the manual gas shutoff valve, wait at least 5 minutes, and relight only after the condition is safe. If it repeats, contact qualified service personnel .
Burner does not ignite	Corresponding pilot is not lit or not stable	Turn all control knobs OFF , close the manual gas shutoff valve, wait at least 5 minutes, then relight pilots before opening burner controls.
	Control knob not opened correctly	Turn all control knobs OFF , close the manual gas shutoff valve if stopping troubleshooting, then review the Burner Controls section before retrying.
	Burner, pilot, or gas component is wet after cleaning	Turn all control knobs OFF , close the manual gas shutoff valve, allow components to dry fully. If ignition remains unreliable, contact qualified service personnel .
	Burner, valve, pilot, or internal gas component issue	Turn all control knobs OFF , close the manual gas shutoff valve, discontinue use, and contact qualified service personnel .
Repeated ignition failure	Startup sequence not followed correctly	Turn all control knobs OFF , close the manual gas shutoff valve, wait at least 5 minutes, then restart exactly as instructed.
	Pilot is not stable before burner control is opened	Turn all control knobs OFF , close the manual gas shutoff valve. Do not continue ignition attempts with an unstable pilot.
Delayed ignition or popping sound	Pilot flame is weak, unstable, or not reaching burner correctly	Turn all control knobs OFF , close the manual gas shutoff valve, discontinue use, and contact qualified service personnel .
	Burner area affected by grease, debris, boil-over, or moisture	Turn all control knobs OFF , close the manual gas shutoff valve, allow to cool, clean accessible areas, and dry fully.
Flame Appearance and Burner Performance		
Burner flame is yellow, orange, or sooty	Dirty burner area, grease buildup, boil-over residue, or blocked airflow	Turn all control knobs OFF , close the manual gas shutoff valve, allow to cool, and clean accessible areas.
	Incorrect gas type, incorrect gas pressure, burner adjustment issue, or air shutter issue	Do not adjust burners or air shutters. Turn all control knobs OFF , close the manual gas shutoff valve, discontinue use, and contact qualified service personnel .
Flame lifts, rolls, floats, or appears unstable	Strong draft, hood imbalance, or excessive air movement	Turn all control knobs OFF , close the manual gas shutoff valve if unsafe, verify hood and make-up air conditions, and eliminate strong drafts where possible.
	Blocked airflow, incorrect gas pressure, air mixture issue, or internal gas issue	Turn all control knobs OFF , close the manual gas shutoff valve, discontinue use, and contact qualified service personnel .
Flame is low on all burners	Manual gas shutoff valve not fully open	If safe, confirm the manual gas shutoff valve is fully open during operation. If troubleshooting continues, turn all control knobs OFF and close the manual gas shutoff valve.
	Gas supply volume is insufficient	Turn all control knobs OFF , close the manual gas shutoff valve, and contact qualified service personnel or gas supplier to verify supply capacity.
Flame is low on one burner	Control setting is low	Adjust the control setting as appropriate for the cooking task.
	Burner, valve, pilot, or orifice issue	Turn all control knobs OFF , close the manual gas shutoff valve, and contact qualified service personnel .
Excessive carbon deposits around burner area	Poor combustion, blocked airflow, dirty burner area, or boil-over residue	Turn all control knobs OFF , close the manual gas shutoff valve, allow to cool, clean accessible areas, and verify airflow.
	Incorrect gas type, pressure, or burner adjustment	Turn all control knobs OFF , close the manual gas shutoff valve, discontinue use, and contact qualified service personnel .

TROUBLESHOOTING GUIDE

Symptom	Possible Cause	Corrective Action
Cooking Performance and Cookware		
Food cooks unevenly	Hot plate not fully preheated	Preheat before loading cookware or food.
	Uneven cookware loading or different cookware types	Use consistent cookware placement and cooking patterns.
	Cookware is warped, unstable, oversized, or not suitable for open gas burners	Use stable, flat-bottom cookware suitable for commercial gas burner cooking.
	Unit is not level	Turn all control knobs OFF , close the manual gas shutoff valve when not in use, allow to cool, and re-level the unit.
	Grates are not seated correctly	Turn all control knobs OFF , close the manual gas shutoff valve, allow to cool, and reinstall grates securely.
One burner cooks differently than another	Different control settings, cookware sizes, or loading pattern	Confirm burner settings, cookware size, and loading pattern.
	Burner, pilot, or gas system issue	Turn all control knobs OFF , close the manual gas shutoff valve, and contact qualified service personnel .
Recovery is slow after loading	Heavy food load, cold cookware, frozen product, or insufficient preheat	Reduce batch size, preheat longer, and allow recovery time.
	Gas supply or ventilation issue	Turn all control knobs OFF , close the manual gas shutoff valve if unsafe, verify hood operation and make-up air, and contact qualified service personnel if unresolved.
Cookware is unstable	Cookware is warped, oversized, too small, or not seated correctly on grate	Turn the affected burner OFF . If unsafe, turn all control knobs OFF , close the manual gas shutoff valve, allow to cool, and replace cookware with suitable stable cookware.
	Grate is not seated correctly, damaged, or missing	Turn all control knobs OFF , close the manual gas shutoff valve, allow to cool, and reinstall or replace grate before operation.
Smoke, Odor, Drip Tray, and Cleaning-Related Issues		
Excessive smoke during first use	Protective coating, manufacturing residue, or initial burn-off	Complete initial burn-off with ventilation operating. If odor smells like gas, turn all control knobs OFF , close the manual gas shutoff valve, and follow gas emergency procedures.
Excessive smoke during normal use	Grease, food debris, boil-over, or carbon buildup	Turn all control knobs OFF , close the manual gas shutoff valve, allow to cool, and clean grates, drip tray, and accessible surfaces.
	Heat setting too high for cookware or food load	Reduce flame setting. If smoke continues, turn all control knobs OFF , close the manual gas shutoff valve, allow to cool, and inspect cleaning condition.
Persistent odor during operation	Grease, food debris, dirty drip tray, boil-over, or carbon buildup	Turn all control knobs OFF , close the manual gas shutoff valve after use, allow to cool, and clean thoroughly.
	Cleaner residue not removed	Turn all control knobs OFF , close the manual gas shutoff valve, allow to cool, clean with approved methods, rinse, and dry completely.
Drip tray overflows	Tray not emptied frequently enough	Turn all control knobs OFF , close the manual gas shutoff valve, allow to cool, then empty, wash, rinse, dry, and reinstall the drip tray.
	High boil-over or heavy grease load	Increase monitoring and emptying frequency after shutdown and cooling.
Grease or debris accumulates under unit	Drip tray missing, full, damaged, or not seated correctly	Turn all control knobs OFF , close the manual gas shutoff valve, allow to cool, clean area, and reinstall or replace drip tray.
Unit does not operate correctly after cleaning	Burner, pilot, control, or gas component area exposed to water or cleaner	Turn all control knobs OFF , close the manual gas shutoff valve, allow to dry fully. If condition persists, contact qualified service personnel .
Ignition problems after cleaning	Water, cleaner, grease, or debris entered pilot or burner area	Turn all control knobs OFF , close the manual gas shutoff valve, allow components to dry fully. If ignition remains unreliable, contact qualified service personnel .
Rust appears on cast iron grates	Grates left wet after cleaning or not lightly oiled when needed	Turn all control knobs OFF , close the manual gas shutoff valve, allow to cool, clean grates, dry thoroughly, and lightly oil grates as appropriate.
Stainless steel staining or corrosion	Harsh cleaner, chlorine, iodine, ammonia, bromine, or	Stop using improper cleaner. Clean and rinse thoroughly with approved methods.

TROUBLESHOOTING GUIDE

Symptom	Possible Cause	Corrective Action
	improper tool exposure	
Scratches on stainless steel	Wrong tool or scrubbing direction	Use non-abrasive cleaners and rub with the grain of the stainless steel.
Ventilation, Installation, and Heat Issues		
Burner flame becomes unstable when hood operates	Strong draft or make-up air imbalance	Turn all control knobs OFF , close the manual gas shutoff valve if unsafe, verify hood and make-up air operation, and eliminate strong drafts where possible.
Pilot goes out when ventilation operates	Draft, make-up air imbalance, or ventilation issue	Turn all control knobs OFF , close the manual gas shutoff valve, discontinue use, and contact qualified service personnel or ventilation professional.
Excessive heat around unit	Improper clearance, blocked airflow, or unsuitable location	Turn all control knobs OFF , close the manual gas shutoff valve, allow to cool, and verify required clearances and ventilation.
Poor recovery or overheating	Flue area obstructed or airflow restricted	Turn all control knobs OFF , close the manual gas shutoff valve, allow to cool, and clear obstruction if accessible and safe.
Unit operates poorly after being moved	Gas connection disturbed	Turn all control knobs OFF , close the manual gas shutoff valve, and do not operate until installation and gas connection are verified by qualified personnel .
	Unit is no longer level	Turn all control knobs OFF , close the manual gas shutoff valve when not in use, allow to cool, and re-level the unit.
Unit seems unstable	Legs not installed correctly or counter is not stable	Turn all control knobs OFF , close the manual gas shutoff valve, and discontinue use until installation is corrected.
Heat damage near surrounding surfaces	Improper clearance, blocked ventilation, or nearby heat-sensitive materials	Turn all control knobs OFF , close the manual gas shutoff valve, remove materials, and verify installation is suitable.
Control Operation		
Control knob sticks, binds, feels loose, or does not turn normally	Damaged, contaminated, or worn control valve	Turn all control knobs OFF , close the manual gas shutoff valve, discontinue use, and contact qualified service personnel .
Control knob does not shut off normally	Valve or control fault	Close the manual gas shutoff valve immediately if safe and contact qualified service personnel .
Burner remains on when knob is OFF	Valve fault or unsafe gas condition	Close the manual gas shutoff valve immediately if safe. Do not operate. Contact qualified service personnel .
Control marking is unclear or knob is damaged	Knob or marking damage	Turn all control knobs OFF , close the manual gas shutoff valve when not in use, and replace damaged parts before operation.

When to Stop and Call for Service

Stop using the unit, turn all control knobs **OFF**, close the manual gas shutoff valve, and contact **qualified service personnel** if any of the following occur:

- gas odor is present
- pilot repeatedly will not light or will not stay lit
- burner does not ignite after normal startup checks
- delayed ignition, popping, soot, or repeated unstable flame occurs
- yellow, lifting, rolling, noisy, or sooty flame continues after cleaning and airflow checks
- control knob sticks, binds, feels loose, or will not shut off normally
- burner remains on when the knob is **OFF**
- visible gas line damage, loose fitting, or suspected leak is present
- unit has been damaged, dropped, moved improperly, or exposed to excessive water
- gas conversion, pressure adjustment, regulator service, pilot adjustment, burner tuning, or internal gas-system work is needed

If troubleshooting points to gas system adjustment, pilot adjustment, burner tuning, regulator service, internal component repair, or any condition involving panel removal or internal disassembly, turn all controls **OFF**, close the manual gas shutoff valve, discontinue use, and contact **qualified service personnel**.

WARRANTY

For full warranty terms, conditions, limitations, and exclusions, please visit:

<https://noriota.ca/pages/warranty-policy>

To register your product online, visit:

<https://noriota.ca/pages/warranty-registration>

Please have your model number and serial number available when registering your product or requesting warranty support.

Scan to register your product online:



SPARE PARTS AND SERVICE INFORMATION

Spare Parts Identification

Replacement parts diagrams and component lists for NORIOTA equipment are available online to support service, maintenance, and parts ordering.

These diagrams are provided for reference and identification purposes only and are intended for use by **qualified service personnel** and authorized dealers when identifying replacement components.

Accessing Spare Parts Diagrams

Current spare parts diagrams and part identification resources can be found at:

www.noriota.ca

Search by model number to locate the appropriate parts documentation. Ensure you are referencing the correct model and revision before selecting parts.

Important Notes Regarding Spare Parts

Spare parts diagrams illustrate component locations and assemblies but do not replace professional service training.

Parts availability may vary by model, production run, or revision.

Always verify the model number and serial number before ordering replacement parts.

Use of non-genuine replacement parts may affect performance, safety, and warranty coverage.

Service and Parts Ordering Guidance

For parts ordering, warranty inquiries, or service assistance, contact your authorized NORIOTA dealer, email support@noriota.ca, or visit www.noriota.ca.

Only **qualified service personnel** should install replacement components, especially gas system, burner, pilot, regulator, or safety-related parts. Improper installation may result in equipment damage, unsafe operation, gas leakage, poor combustion, or affected warranty coverage.

Rating Label Information

The rating label contains important technical and identification information for the unit, including:

- model number
- serial number
- gas type
- input rating
- manifold pressure requirements
- clearance requirements
- certification information, including applicable safety and sanitation standards

Always verify that the gas type, input rating, manifold pressure, clearance requirements, and installation requirements shown on the rating label match the installation site and utility supply before placing the unit into service.

Rating Label Location

The rating label is located on the unit in a visible service-access location. The exact location may vary by model.

Do not remove, cover, deface, or paint over the rating label. The rating label must remain legible for the life of the equipment.

COMMISSIONING RECORD

Record the information below at the time of installation. This record helps confirm proper installation conditions, supports future service, and may assist in warranty evaluation. Retain this page for your records.

UNIT AND PURCHASE INFORMATION

Model Number: _____

Serial Number: _____

Date of Purchase: _____

Purchased From (Dealer / Supplier): _____

Dealer Contact (if available): _____

INSTALLATION DETAILS

Installation Date: _____

Installation Location (Site / Address): _____

Installed By (Company / Technician Name): _____

Installer Contact (if available): _____

<p>GAS SUPPLY VERIFICATION</p> <p>Gas Type (Natural Gas/LP Gas): _____</p> <p>Supply Pressure (measured): _____</p> <p><input type="checkbox"/> Verified matches range on rating label or manual</p> <p>Manifold Pressure (measured): _____</p> <p><input type="checkbox"/> Verified matches rating label specification</p> <p>Gas Pressure Regulator Installed Correctly: <input type="checkbox"/> Yes <input type="checkbox"/> No</p> <p>Gas Connection Leak Checked: <input type="checkbox"/> Yes <input type="checkbox"/> No</p> <p>Manual Shutoff Valve Accessible: <input type="checkbox"/> Yes <input type="checkbox"/> No</p>	<p>UNIT SETUP AND CONDITIONS</p> <p>Unit Level Confirmed: <input type="checkbox"/> Yes <input type="checkbox"/> No</p> <p>Legs Installed Properly: <input type="checkbox"/> Yes <input type="checkbox"/> No</p> <p>Clearances Verified: <input type="checkbox"/> Yes <input type="checkbox"/> No</p> <p>Ventilation / Hood Operation Verified: <input type="checkbox"/> Yes <input type="checkbox"/> No</p> <p>Flue Area Unobstructed: <input type="checkbox"/> Yes <input type="checkbox"/> No</p> <p>Packaging, Protective Film, and Shipping Materials Removed: <input type="checkbox"/> Yes <input type="checkbox"/> No</p> <p>Drip Tray Properly Seated: <input type="checkbox"/> Yes <input type="checkbox"/> No</p>
<p>INITIAL OPERATION CHECK</p>	
<p>Pilots Light and Remain Stable: <input type="checkbox"/> Yes <input type="checkbox"/> No</p> <p>Burners Ignite and Operate Correctly: <input type="checkbox"/> Yes <input type="checkbox"/> No</p> <p>Burner Flames Stable and Predominantly Blue: <input type="checkbox"/> Yes <input type="checkbox"/> No</p> <p>Control Knobs Operate Smoothly and Shut Off Properly: <input type="checkbox"/> Yes <input type="checkbox"/> No</p> <p>Gas Odor Present: <input type="checkbox"/> Yes <input type="checkbox"/> No - if yes, do not operate</p>	<p>Initial Burn-Off Completed: <input type="checkbox"/> Yes <input type="checkbox"/> No</p> <p>Active Burner Zones Heat and Respond Normally: <input type="checkbox"/> Yes <input type="checkbox"/> No</p> <p>Cookware Sits Securely on Grates During Test: <input type="checkbox"/> Yes <input type="checkbox"/> No</p> <p>Ambient Temperature at Installation: _____</p> <p>Abnormal Noise or Vibration: <input type="checkbox"/> Yes <input type="checkbox"/> No</p>

NOTES / OBSERVATIONS

INSTALLER CONFIRMATION

Installer Name: _____

Signature: _____

Date: _____

6 Loring Drive, Bolton, Ontario L7E 1H5 | 1-877-667-4678 (1-877-NORIOTA)
support@noriota.ca
www.noriota.ca

© 2026 NORIOTA. All rights reserved.