

# NORIOTA

## INSTALLATION AND INSTRUCTION MANUAL

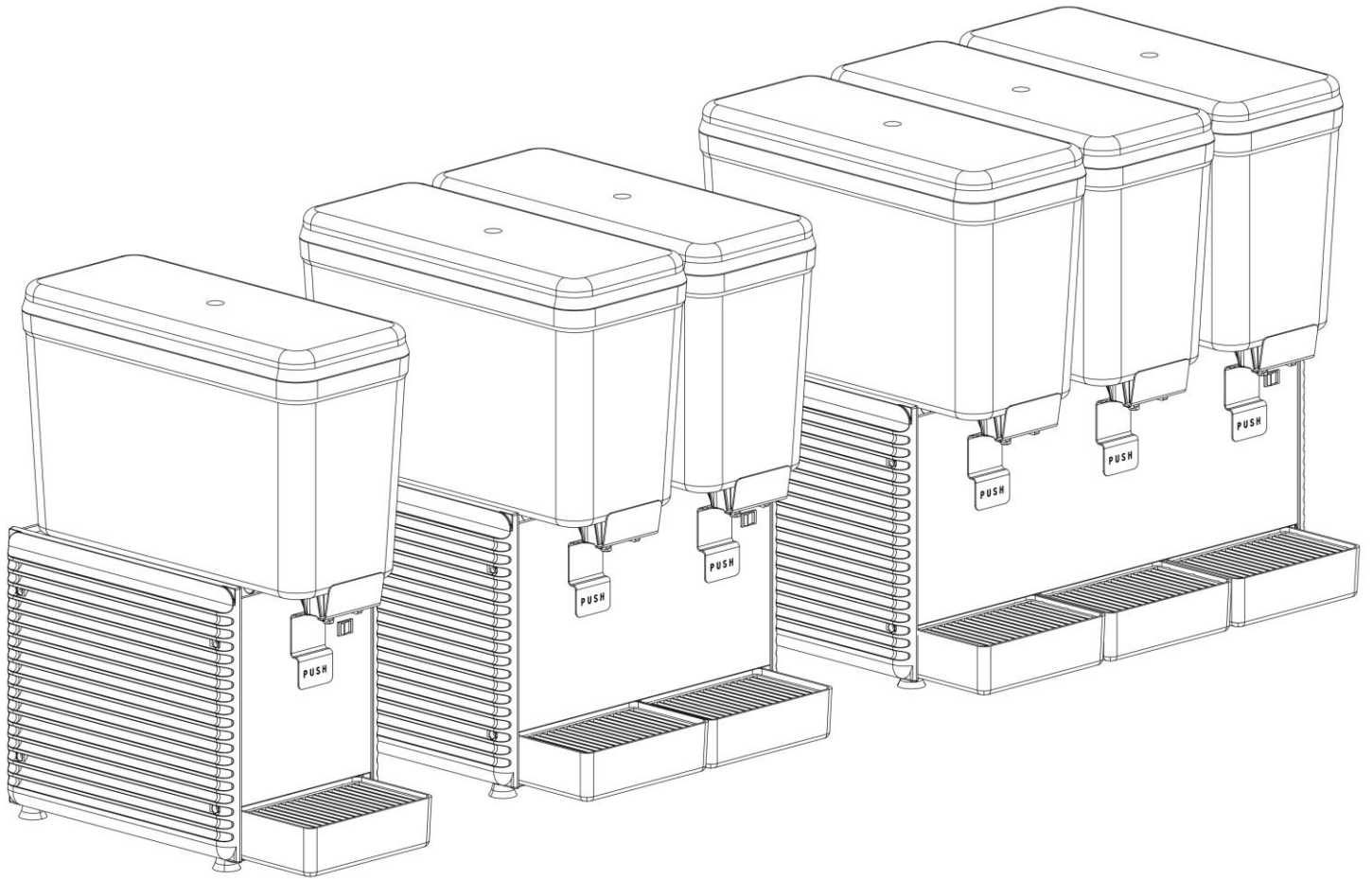

**DISP AND NBD SERIES**

**REFRIGERATED BEVERAGE DISPENSERS**

## QUICK START AND KEY OPERATING REMINDERS



### NOTICE!

This guide highlights important safety and operating reminders only. It does not replace the full Installation and Instruction Manual. Read and follow the full manual before installing, operating, cleaning, or servicing this unit.

### Before Filling the Bowls

- Allow unit to remain upright and unplugged for at least 24 hours if tilted, laid on its back, side, upside down, or transported non-upright. If kept upright continuously, wait at least 10 minutes before startup.
- Confirm the unit is level, stable, and connected to a properly grounded electrical outlet.
- Confirm required airflow clearances are maintained and airflow openings are unobstructed.
- Confirm bowls, bowl gaskets, dispensing valves, and dispensing valve O-rings are correctly installed.
- Never fill a bowl unless the stir rod and stirring paddle are properly installed.
- Confirm all dispensing valves are fully assembled and leak-free before filling.

### Filling the Bowls

- Prepare beverage products according to the beverage manufacturer's instructions.
- Mix concentrates completely before filling the bowls.
- Fill each bowl above the minimum operating level.
- Do not operate refrigeration or stirring systems with empty bowls.
- Extremely thick, pulpy, or unsuitable products may not circulate properly.

### Starting the Unit

1. Turn the Stirring Control Switch ON.
2. Turn the Refrigeration Control Switch ON.
3. Verify the beverage circulates normally and no leaks are present.
4. Allow sufficient time for the beverage to cool before serving.

Warm product may require several hours to reach serving temperature. Pre-chilled product will cool faster and may improve performance during startup.

### Daily Operation

- During normal operation, leave BOTH the stirring and refrigeration switches ON.
- This equipment is designed for continuous commercial operation and should normally remain ON overnight and during non-business hours when beverage remains in the bowls.
- Maintain proper beverage levels during operation.
- Keep lids installed whenever possible to improve sanitation and cooling performance.
- Investigate any leakage immediately.

### Daily Cleaning Reminder

- Drain, clean, rinse, and sanitize all food-contact components daily.
- Clean bowls, dispensing valves, drip trays, stir rods, stirring paddles, and gaskets thoroughly.
- Confirm all components are correctly reassembled before refilling.

### Preventive Maintenance

- Inspect the condenser monthly and clean as required.
- Keep airflow openings free of dust, grease, lint, and debris.
- Inspect gaskets, O-rings, and dispensing valves regularly for wear or damage.
- Refer to the user manual for cleaning, maintenance, troubleshooting, and service information.

### Need Help

For product support, manuals, or service assistance:



Website  
[www.noriota.ca](http://www.noriota.ca)



Phone  
1-877-NORIOTA



Email  
[support@noriota.ca](mailto:support@noriota.ca)

Please have your model and serial number available when contacting support.

# TABLE OF CONTENTS

INTRODUCTION.....	3
Important Information for Owners and Operators.....	3
Intended Use.....	3
Manual Scope and Updates.....	3
Technical Information.....	3
RECEIVING AND INSPECTING THE EQUIPMENT.....	4
Important Handling Notes.....	4
Receiving Inspection.....	4
Concealed Damage Inspection.....	4
Reporting Damage.....	4
Serial Number Information.....	4
SAFETY INFORMATION.....	5
Electrical Shock Hazard.....	5
Food Safety and Sanitation Hazard.....	5
General Safety Instructions.....	6
Electrical Safety.....	6
Refrigeration and Ventilation Hazard.....	6
Mechanical, Moving Part, and Surface Safety.....	7
Equipment Handling and Misuse.....	7
Cleaning and Sanitation Safety.....	7
Service and Repair Safety.....	8
Unit Disposal.....	8
INSTALLATION.....	9
Installation Responsibility and Code Compliance.....	9
Pre-Installation Checklist.....	9
Compressor Settling Time.....	9
Unpacking and Packaging Removal.....	9
Location and Placement Requirements.....	10
Electrical Supply Requirements.....	10
Clearance and Ventilation Requirements.....	11
Leveling, Adjustable Feet, and Optional Raised Legs.....	12
Final Installation Checks.....	12
Installation and Warranty Conditions.....	12
OPERATION.....	13
Components and Control Overview.....	13
How the Refrigerated Beverage Dispenser Works.....	15
Before First Use.....	15
Initial Startup and First Fill Check.....	16
Beverage Preparation and Filling.....	16
Cooling Expectations.....	16
Normal Operation.....	17
Dispensing.....	17
Operating Multi-Bowl Units.....	18
Shutdown Procedure.....	18
CLEANING AND MAINTENANCE.....	19
Cleaning and Maintenance Safety.....	19
Cleaning, Sanitizing, and Reassembly Procedure.....	19
Preventive Maintenance and Service Boundary.....	22
Recommended Cleaning and Maintenance Schedule.....	22
Maintenance Log.....	23
TROUBLESHOOTING GUIDE.....	24
Before Calling for Service.....	24
When to Stop and Call for Service.....	26
CIRCUIT DIAGRAM.....	28
WARRANTY, SERVICE, AND SPARE PARTS.....	29
COMMISSIONING RECORD.....	30

## INTRODUCTION

This manual provides installation, operation, cleaning, maintenance, and troubleshooting guidance for NORIOTA refrigerated beverage dispensers. These units are designed to refrigerate, circulate, display, and dispense pre-mixed cold beverages in commercial foodservice environments.

This manual applies to the following models: DISP1, DISP2, DISP3, DISP1S, DISP2S, DISP3S, NBD1, NBD2, NBD3, NBD1SS, NBD2SS, NBD3SS. Always refer to the unit rating label for exact technical information, including model identification, serial number, electrical requirements, refrigerant type, and refrigerant charge.

### Important Information for Owners and Operators

Read this manual completely before installing, operating, cleaning, or servicing the equipment.

- This equipment is intended for indoor commercial use only.
- Operators must be trained in safe food handling, cleaning, sanitizing, and routine equipment operation.
- Keep the unit upright during transport, storage, handling, and installation.
- Do not operate the unit if the power cord, plug, bowl, dispensing valve, gasket, controls, panels, refrigeration system, or electrical components appear damaged or are not functioning properly.
- Keep this manual readily accessible for operators and service personnel.

### Intended Use

NORIOTA refrigerated beverage dispensers are designed for commercial use in restaurants, cafés, bars, hotels, convenience stores, cafeterias, catering operations, institutional facilities, and similar foodservice environments.

These units are intended for pre-mixed, non-carbonated cold beverages that can be safely held, circulated, and dispensed from a refrigerated beverage dispenser. Beverage selection, preparation, storage time, cleaning frequency, and sanitation practices must comply with applicable food safety requirements and the beverage manufacturer's instructions.

This equipment is not intended for:

- Household or residential use or outdoor installation
- Carbonated beverages or hot liquids
- Frozen beverage production
- Beverages containing large fruit pieces, large pulp, seeds, or solids that may block the dispensing system
- Storage of chemicals, medicine, laboratory materials, or non-food products
- Use in environments with excessive airborne grease, corrosive chemicals, flammable vapours, or uncontrolled ambient conditions

### Manual Scope and Updates

This manual provides user-level installation, operation, cleaning, maintenance, and troubleshooting guidance. It does not provide sealed refrigeration-system repair, refrigerant recovery, refrigerant charging, compressor replacement, internal electrical diagnostics, or advanced service procedures.

NORIOTA may update specifications, components, materials, designs, or instructions without notice as part of ongoing product improvement. Always use the rating label on the specific unit as the highest-priority reference for electrical and refrigeration data.

### Technical Information

Specification	DISP1 / DISP1S NBD1 / NBD1SS	DISP2 / DISP2S NBD2 / NBD2SS	DISP3 / DISP3S NBD3 / NBD3SS
Electrical Supply	120 V / 60 Hz / 1 Ph		
Plug Type	NEMA 5-15P		
Wattage	226 W	345 W	510 W
Compressor	1/5 HP	1/4 HP	1/3 HP
Refrigerant	R-134a, 4.24 oz (120 g)	R-134a, 7.34 oz (208 g)	R-134a, 11.47 oz (325 g)
Bowl Capacity	One (1) 3-gallon bowl	Two (2) 3-gallon bowls	Three (3) 3-gallon bowls
Recommended Ambient Temperature	15 °C to 25 °C (59 °F to 77 °F)		
Recommended Clearance	20 cm (8 in) sides and rear		

## RECEIVING AND INSPECTING THE EQUIPMENT

Carefully inspect the equipment immediately upon delivery and before installation. Transportation, handling, storage conditions, and movement during delivery may result in concealed or visible damage that is not immediately apparent until the unit is unpacked.

Do not discard packaging materials until inspection is complete and the unit has been confirmed to be in acceptable condition. If shipping damage, concealed damage, missing components, refrigeration tubing damage, electrical damage, bowl damage, dispensing component damage, or other abnormal conditions are identified, report the issue promptly to the carrier, dealer, or NORIOTA support.

### Important Handling Notes

- Keep the unit upright during transportation, handling, movement, storage, and installation. Do not lay the unit on its side, front, rear, or upside down.
- Do not tip, drop, strike, or subject the unit to excessive impact during unloading or movement.
- Use appropriate equipment and sufficient assistance when unloading, lifting, or moving the unit.
- Do not lift, pull, or move the unit by the power cord, plug, bowls, lids, dispensing handles, control switches, drip trays, side panels, or airflow openings.
- Protect the bowls, lids, dispensing handles, control switches, condenser airflow openings, power cord, plug, feet, and exterior panels during handling and setup.

### Receiving Inspection

When the shipment arrives:

- Inspect exterior packaging, pallet, straps, wrap, and visible shipping materials before acceptance.
- Check for signs of impact, punctures, crushing, tipped handling, torn packaging, water exposure, broken foam, loose contents, damaged pallet, missing straps, or other evidence of mishandling in transit.
- If visible damage is found, photograph the packaging, pallet, shipping label, and damaged areas before unpacking whenever practical.
- If a delivery receipt, bill of lading, courier device, or delivery document is provided, note the damage in as much detail as possible before signing, if applicable.

### Concealed Damage Inspection

Perform concealed damage inspection as soon as possible after delivery and unpacking. Freight carriers and delivery providers may limit the time allowed to report concealed shipping damage.

After unpacking:

- Inspect cabinet panels, bowls, lids, dispensing handles, drip trays, control switches, refrigeration lines, fittings, power cord, plug, and airflow openings carefully.
- Verify unit sits level and stable without distortion and bowls, gaskets, dispensing components, drip trays, and loose accessories are present and not cracked, distorted, or damaged.
- Verify there are no unusual odours, residue, loose components, broken fittings, crushed airflow openings, or signs of refrigerant leakage.

If concealed damage is identified:

- Retain all packaging materials.
- Document the condition with photographs.
- Contact the carrier and equipment supplier promptly.
- Do not attempt refrigeration system repair or operate a damaged unit.

### Reporting Damage

- **Visible damage:** Note the damage in as much detail as possible on the delivery receipt, bill of lading, courier device, or delivery document before signing whenever practical. Photograph exterior packaging, shipping label, pallet, and damaged areas before unpacking or discarding packaging materials. Report visible damage promptly after receipt.
- **Concealed damage:** Report concealed damage promptly after unpacking and inspection. Retain packaging materials and photograph the damaged unit, packaging, and any abnormal conditions.

### Serial Number Information

The model number and serial number are located on the unit rating label. Always have the model number and serial number available when contacting NORIOTA, the seller, or an authorized service provider for parts, service, warranty support, technical assistance, or freight-related documentation.

## SAFETY INFORMATION

Commercial refrigerated beverage dispensers operate with electrically powered refrigeration components, moving agitator components, condenser fans, cold product bowls, dispensing valves, removable gaskets, cleaning and sanitizing chemicals, sharp metal edges, electrical components, and pressurized refrigeration components. Improper installation, operation, cleaning, sanitizing, maintenance, handling, or servicing may result in electrical shock, refrigerant exposure, product leakage, unsanitary beverage conditions, poor cooling performance, equipment damage, property damage, personal injury, or unsafe operating conditions.

Read and follow all safety instructions in this manual before installing, operating, cleaning, sanitizing, moving, or servicing this equipment.



This is the Safety Alert Symbol. This symbol alerts you to potential hazards that can injure or kill you and others. All safety messages will follow the Safety Alert Symbol and either the words “**DANGER**”, “**WARNING**” or “**CAUTION**”.

**DANGER!**

This symbol indicates a hazardous situation which will result in death or serious injury.

**WARNING!**

This symbol indicates a hazardous situation or unsafe practice which, if not avoided, could result in death or serious injury.

**CAUTION!**

This symbol indicates a potential hazard or unsafe condition that may result in injury, equipment damage, or property damage.

**NOTICE!**

This symbol indicates important information related to proper use, installation, or maintenance of the equipment that does not involve a personal injury hazard.

All safety messages identify the hazard, explain how to reduce the risk, and describe the possible consequences if instructions are not followed.

**WARNING!****Electrical Shock Hazard**

- Plug only into a properly grounded electrical outlet matching the voltage shown on the rating label.
- Do not immerse the unit, power cord, or plug in water or any other liquid.
- Do not spray, hose down, pressure clean, or steam clean the unit.
- Do not operate the unit with a damaged cord, damaged plug, damaged controls, damaged wiring, water intrusion, or signs of electrical malfunction.
- Disconnect power before cleaning, inspection, movement, maintenance, or service.

**CAUTION!****Food Safety and Sanitation Hazard**

- Improper cleaning, sanitizing, beverage handling, or maintenance may result in unsanitary beverage conditions, product contamination, off flavours, mould growth, or unsafe operation.
- Follow all cleaning and sanitizing instructions in this manual and use only food-safe cleaning and sanitizing products suitable for commercial beverage equipment.
- Empty and clean the bowls before extended shutdown, storage, transport, or periods of non-use.
- Beverage quality, product holding time, cleaning frequency, and sanitizing procedures must comply with applicable food safety requirements and beverage manufacturer recommendations.
- Do not continue using the unit if beverage leakage, gasket leakage, valve leakage, cracked bowls, or residue buildup may create unsanitary conditions, slip hazards, or contamination risk. Empty, clean, inspect, and reassemble the unit before returning it to service.
- Use only clean mixing tools and potable water when preparing beverages. Follow the beverage manufacturer’s mixing, dilution, holding, and disposal instructions.

## SAFETY INFORMATION



### NOTICE!

- This equipment is intended for commercial foodservice use only. It is not intended for household, residential, or other non-commercial use.
- Installation, setup, electrical connection, placement, cleaning, maintenance, and service must be performed in accordance with this manual and all applicable local codes and regulations.
- Use of non-approved parts, improper installation, blocked airflow, improper cleaning or sanitizing, unauthorized service, or operation outside the conditions described in this manual may result in unsafe conditions, equipment damage, reduced performance, product leakage, or unsanitary beverage conditions, and may affect warranty coverage.

### General Safety Instructions

- Read this manual completely before installing, operating, cleaning, sanitizing, moving, or servicing.
- Do not operate the unit if it has been damaged, dropped, improperly handled, exposed to excessive moisture, or shows signs of unsafe operation.
- Do not operate the unit with damaged bowls, damaged dispensing components, damaged refrigeration tubing, damaged wiring, damaged controls, damaged airflow openings, missing components, or abnormal operation.
- Do not operate unit below or above the operating ambient temperature range specified in this manual.
- Use only beverages suitable for refrigerated beverage dispenser operation.
- Do not place hands, utensils, tools, bottles, cans, packaging, or foreign objects inside the bowls during operation.
- Do not insert fingers, utensils, cleaning tools, packaging materials, or other objects into airflow openings, ventilation louvers, or condenser areas.
- Do not place electrical appliances, heaters, tools, or non-approved devices on, inside, or against the unit.
- This equipment is not intended for use by children or untrained persons. Children should be supervised and must not play with, clean, or maintain the equipment.
- Do not operate the unit unattended in public-access areas. Closely supervise operation where customers, children, or unauthorized persons may access the unit.

### Electrical Safety



### WARNING!

Improper electrical connection, damaged cords, lack of grounding, water intrusion, wet electrical components, or unauthorized electrical service may result in electrical shock, fire, equipment damage, serious injury, or death.

- Do not cut, remove, modify, or bypass the grounding prong on the power cord.
- Connect only to a properly grounded outlet that matches voltage and frequency shown on rating label.
- Connect the unit to a dedicated outlet. Do not share the outlet with other electrical devices.
- If grounding, outlet condition, circuit capacity, or electrical-code compliance is uncertain, have the outlet and circuit inspected by a qualified electrician before use.
- Do not use extension cords, adapters, power strips, damaged outlets, or ungrounded electrical connections.
- Do not connect or disconnect the power plug with wet hands.
- When unplugging the unit, grasp the plug firmly and pull straight out from the outlet. Do not unplug the unit by pulling on the power cord.
- Ensure the unit is not resting on, pinching, sharply bending, or damaging the power cord during installation, movement, or operation.
- Keep electrical components, control switches, wiring areas, power cord, and plug dry during operation, cleaning, and maintenance.
- If the power cord is damaged, it must be replaced only by qualified service personnel using an approved replacement cord or assembly.
- Electrical service, wiring repair, internal diagnostics, control replacement, and power cord replacement must be performed only by qualified service personnel.

### Refrigeration and Ventilation Hazard



### CAUTION!

Improper ventilation, blocked airflow, dirty condenser surfaces, high ambient temperatures, damaged refrigeration components, or improper operation may result in poor cooling performance, compressor overheating, refrigerant-system damage, product spoilage, equipment damage, or unsafe operating conditions.

## SAFETY INFORMATION

- Maintain the required installation clearances around the unit at all times.
- Do not block, cover, or restrict airflow openings on the sides or rear of the unit.
- Keep the condenser area clean and free of dust, lint, grease, paper, cardboard, and other debris.
- Do not operate in direct sunlight or near ovens, grills, fryers, steam equipment, or other major heat sources.
- Operate the unit only within the recommended ambient temperature range described in this manual.
- Do not use the unit if refrigeration tubing appears damaged, leaking, crushed, or heavily corroded.
- Do not puncture, cut, drill, heat, or modify refrigeration tubing or refrigeration-system components.
- Allow several minutes after unplugging the unit or after a power interruption before restarting the unit to help protect the compressor from short cycling.
- Refrigeration-system diagnosis, refrigerant handling, compressor replacement, refrigerant charging, and sealed-system repairs must be performed only by qualified refrigeration service personnel.

### Mechanical, Moving Part, and Surface Safety



#### CAUTION!

Moving components, dispensing mechanisms, rotating agitator components, sharp metal edges, cold surfaces, and recently operated refrigeration components may cause injury or equipment damage if handled improperly.

- Keep hands, fingers, hair, clothing, utensils, tools, and loose objects away from moving agitator components during operation.
- Do not operate the unit with missing, damaged, improperly installed, or loose bowls, lids, dispensing components, agitators, gaskets, drip trays, or panels.
- Use caution when handling dispensing handles, pinch points, removable components, and sheet metal edges during cleaning or maintenance.
- Do not insert hands or objects into moving beverage or agitator areas while the unit is operating.
- Interior cooling surfaces and refrigeration components may become very cold during operation. Use caution during cleaning and maintenance.
- Compressor and condenser areas may become warm during normal operation. Allow components to cool before servicing or cleaning nearby areas.
- Use caution when lifting, removing, cleaning, or reinstalling bowls and removable components to avoid dropping, cracking, or damaging parts.
- Do not force components into position during assembly or reassembly. Improper assembly may result in leakage, poor operation, or component damage.

### Equipment Handling and Misuse



#### CAUTION!

Improper handling, unstable placement, unauthorized modification, missing components, misuse, or operation outside this manual may result in personal injury, product leakage, equipment damage, unsafe operation, reduced performance, or affected warranty coverage.

- Use appropriate equipment and sufficient personnel when unloading, moving, lifting, or positioning unit.
- Do not lift, pull, push, or move the unit by the power cord, plug, bowls, lids, dispensing handles, control switches, drip trays, side panels, airflow openings, or removable components.
- Keep the unit upright during transportation, storage, handling, movement, and installation. Do not lay the unit on its side or upside down.
- Do not remove panels, guards, covers, or safety devices except as instructed for operator-level cleaning or maintenance.
- Do not store food, bottles, chemicals, packaging, tools, utensils, or non-beverage items in the bowls or on the unit.
- Place unit on a stable, level counter capable of supporting the unit when all bowls are filled to capacity.

### Cleaning and Sanitation Safety



#### WARNING!

Failure to disconnect power when required, follow proper cleaning and sanitizing procedures, or use approved cleaning methods may result in electrical shock, unsanitary beverage conditions, chemical exposure, product leakage, equipment damage, or unsafe operating conditions.

- Disconnect power before manual cleaning, disassembly, inspection, maintenance, or service unless a specific procedure in this manual instructs that power must remain connected for controlled circulation.
- Allow moving components and refrigeration surfaces to stop and stabilize before cleaning or inspection.
- Do not immerse the unit, power cord, or plug in water or any other liquid.
- Do not spray, hose down, pressure clean, steam clean, or clean the unit with a water jet.

## SAFETY INFORMATION

- Prevent water, cleaning chemicals, sanitizer, grease, pulp, sugar residue, or debris from entering electrical areas, controls, wiring, fan areas, condenser areas, or airflow openings.
- Use only food-safe cleaning and sanitizing products suitable for commercial beverage equipment.
- Do not use steel wool, metal scrapers, abrasive pads, abrasive powders, highly corrosive cleaners, or chemicals not intended for commercial beverage dispensers or plastic food-contact components.
- Do not wash bowls, lids, dispensing components, gaskets, agitator components, or removable plastic parts in a dishwasher unless NORIOTA specifically approves that component for dishwasher use.
- Do not mix cleaning chemicals, sanitizers, chlorine products, or acids.
- Rinse, drain, and air-dry components as instructed before returning the unit to service.
- Do not leave cleaning solution, sanitizer, beverage residue, or chemical residue inside bowls, dispensing components, gaskets, or beverage-contact areas after cleaning.
- Do not soak nozzles, dispensing components, or plastic parts in chlorine solution overnight. Prolonged chlorine exposure may cause swelling, deterioration, leakage, or component damage.
- Confirm all gaskets, bowls, dispensing components, seals, and removable parts are clean, undamaged, properly seated, and correctly installed before operation. Improper gasket or component installation may result in beverage leakage, unsanitary conditions, poor dispensing performance, or equipment damage.
- If the unit has been exposed to excessive water intrusion, discontinue use and contact qualified service personnel before reconnecting power.

### Service and Repair Safety



#### WARNING!

Improper service, unauthorized modification, incorrect replacement parts, or unauthorized refrigeration-system work may result in electrical shock, refrigerant leakage, equipment damage, unsafe operation, serious injury, or affected warranty coverage.

- Internal electrical service and refrigeration-system service must be performed by qualified service personnel only.
- Do not attempt to repair, modify, bypass, or alter refrigeration components, controls, wiring, fan, compressor, sealed-system, or airflow components, or safety devices.
- Use only approved replacement parts suitable for the specific model being serviced.
- Do not operate the unit with damaged wiring, damaged refrigeration tubing, loose electrical connections, damaged controls, damaged airflow openings, missing panels, product leakage, water intrusion, or abnormal operation.
- If abnormal odour, suspected refrigerant leakage, smoke, sparking, repeated breaker tripping, fan failure, compressor overheating, electrical malfunction, water intrusion, or abnormal operation occurs, discontinue use and contact qualified service personnel immediately.
- Do not modify the plug, grounding system, electrical supply configuration, refrigeration system, controls, airflow system, bowls, dispensing components, or safety devices.
- Refrigerant handling, recovery, sealed-system repair, charging, and diagnostics must be performed only by qualified refrigeration service personnel.
- After service, cleaning, inspection, or maintenance, confirm all covers, guards, fasteners, panels, bowls, gaskets, dispensing components, drip trays, and required components are properly reinstalled before operation. Do not operate the unit with panels, guards, covers, or required components removed.

### Unit Disposal



#### CAUTION!

Improper disposal, handling, abandonment, or removal from service may result in electrical hazard, refrigerant hazard, cuts, environmental concerns, equipment damage, or regulatory non-compliance.

- Disconnect the unit from the electrical supply before disposal, transport, storage, or removal from service.
- Do not leave discarded equipment accessible to children or unauthorized persons.
- Empty, clean, sanitize, rinse, and dry all bowls, dispensing components, gaskets, drip trays, and beverage-contact surfaces before storage, transport, or disposal.
- Do not puncture, cut, heat, or damage refrigeration tubing or sealed-system components during removal or disposal.
- Refrigerant recovery and sealed-system handling must be performed only by qualified service personnel.
- Refrigerant, compressor oil, refrigeration components, plastic components, electrical parts, and related materials must be recovered, recycled, or disposed of in accordance with all applicable local, provincial, state, and federal regulations.
- Deliver discarded equipment to an authorized recycling, recovery, or collection facility in accordance with applicable regulations.

## INSTALLATION

Proper installation is essential for safe operation, electrical safety, refrigeration-system performance, airflow, beverage cooling performance, sanitation, leak prevention, and long equipment life. Improper installation, unstable placement, blocked airflow, improper electrical supply, failure to maintain required clearances, or failure to follow installation requirements may result in electrical shock, refrigerant-system damage, product leakage, poor cooling performance, equipment damage, property damage, or unsafe operating conditions.

Read the entire installation section before connecting power or placing the unit into service.

### Installation Responsibility and Code Compliance

 <b style="font-size: 1.2em; padding: 5px;">WARNING!</b>	<p>Improper electrical connection, incorrect voltage supply, lack of grounding, damaged wiring, unstable placement, blocked airflow, or failure to follow applicable codes may result in serious injury, electrical shock, equipment damage, or unsafe operating conditions.</p>
---	--

- Installation, electrical connection, inspection, and service must be performed in accordance with this manual and all applicable local codes and regulations.
- Electrical installation must comply with applicable electrical codes and authority requirements.
  - In Canada, electrical installation must comply with CSA C22.1, Canadian Electrical Code, and applicable local authority requirements.
  - In the United States, electrical installation must comply with ANSI/NFPA 70, National Electrical Code, and applicable local authority requirements.
- Refrigeration system service should comply with applicable refrigeration safety regulations including ANSI/ASHRAE 15, Safety Standard for Refrigeration Systems, where applicable.

### Pre-Installation Checklist

Before installing or operating the unit, verify the following:

- The unit arrived without visible shipping damage, concealed damage, or missing components.
- All packaging materials, protective film, tape, foam, and shipping supports have been removed.
- The model number and electrical information on the rating label match the installation location requirements.
- The electrical supply matches the voltage and frequency shown on the rating label.
- A properly grounded dedicated outlet is available for the unit.
- The installation location is indoors, clean, dry, stable, and properly ventilated.
- Ambient room temperature remains within the operating range specified in this manual.
- The countertop or support surface is level and capable of supporting the unit when all bowls are filled to capacity.
- Required installation clearances can be maintained on sides and rear of the unit.
- The power cord, plug, controls, airflow openings, and exterior panels are undamaged.
- The condenser airflow openings are unobstructed and free of packing material or debris.
- Unit has remained upright during transport and positioning. If the unit has been tilted, laid on its front, back, side or upside down, or transported non-upright, allow it to stand upright for at least 24 hours before connecting power.
- Bowls, lids, dispensing components, drip trays, agitators, gaskets, and removable components are properly installed and undamaged.

### Compressor Settling Time

 <b style="font-size: 1.2em; padding: 5px;">NOTICE!</b>	<p>If the unit was tilted excessively, laid on its front, back, side or upside down, or transported in a non-upright position, allow the unit to remain upright and disconnected from power for at least 24 hours before operating. If the unit remained upright during transport and positioning, allow a minimum of 10 minutes before powering on.</p>
--	--

### Unpacking and Packaging Removal

 <b style="font-size: 1.2em; padding: 5px;">CAUTION!</b>	<p>Failure to remove packaging materials, shipping restraints, or protective coverings may result in blocked airflow, abnormal operation, product leakage, equipment damage, or unsafe operating conditions.</p>
---	--

Carefully remove all packaging materials, tape, protective film, shipping supports, and accessories before installation or operation. Do not discard packaging materials until the receiving inspection is complete and the unit has been confirmed to be in acceptable condition.

# INSTALLATION

- Inspect the unit and packaging for visible or concealed shipping damage before installation.
- Remove all exterior and interior packaging materials, protective film, tape, foam, cardboard, plastic ties, and shipping restraints before connecting power.
- Remove all accessories, documentation, adjustable feet, drip trays, loose components, and packaged parts from the unit before operation.
- Do not remove the rating label, serial number label, warning labels, permanent instruction labels, or certification labels from the unit.
- Inspect the bowl area, cooling surfaces, dispensing components, drip tray area, condenser airflow openings, and underside of the unit for loose packaging materials or debris before startup.
- Clean and sanitize bowls, lids, dispensing components, gaskets, drip trays, and accessible food-contact surfaces before first use following the cleaning instructions in this manual.
- Do not use sharp tools, knives, abrasive pads, flammable liquids, or aggressive chemicals to remove packaging materials or adhesive residue.
- If adhesive residue remains after film or tape removal, use a soft cloth and a cleaner suitable for the affected surface.
- Confirm all panels, bowls, lids, dispensing components, drip trays, gaskets, agitator components, and removable parts are properly installed before operation.

## Location and Placement Requirements



### CAUTION!

Improper installation location, unstable placement, blocked airflow, excessive heat exposure, outdoor installation, or operation outside recommended environmental conditions may result in poor cooling performance, product leakage, refrigeration-system stress, equipment damage, or unsafe operating conditions.

- This unit is intended for indoor commercial use only.
- Install the unit in a clean, dry, well-ventilated location protected from rain, direct weather exposure, water spray, standing water, excessive humidity, freezing conditions, and outdoor environments.
- Install the unit on a stable, level countertop or support surface capable of supporting the unit when all bowls are filled to capacity.
- Do not install the unit adjacent to ovens, grills, fryers, steam equipment, dishwashers, ice machines, coffee equipment, or other major heat-producing equipment whenever possible.
- Do not install the unit in direct sunlight or in locations exposed to excessive radiant heat.
- Maintain the recommended ambient room temperature range specified in this manual.
- Ensure the installation location provides adequate ventilation and required airflow clearances for proper condenser cooling and service access.
- Keep condenser airflow openings unobstructed at all times.
- Allow sufficient access for cleaning, inspection, electrical connection, and service.
- The installation location should allow the unit to be moved or accessed for service when necessary.
- Ensure the power plug remains accessible after installation.
- Do not install the unit in locations where product leakage, cleaning water, or condensate could create slip hazards or property damage.

Requirement	Specification
Recommended ambient operating range	15 °C to 25 °C (59 °F to 77 °F)

## Electrical Supply Requirements

Improper electrical supply, incorrect voltage, inadequate grounding, damaged wiring, overloaded circuits, or failure to follow electrical requirements may result in electrical shock, fire hazard, equipment damage, or unsafe operation.

- Verify the electrical supply matches the voltage, frequency, and electrical requirements shown on the rating label before connecting power.
  - The rating label on the unit overrides general electrical information in this manual.
- This unit requires a properly grounded electrical supply.
- Connect the unit only to a dedicated properly grounded outlet of the correct voltage and circuit capacity.
- The power plug must remain accessible after installation so the unit can be disconnected from power when required.
- Use an outlet that cannot be turned off by a wall switch, pull chain, timer, or power-control device.
- Do not remove, modify, or bypass the grounding prong.
- Do not use extension cords, adapters, power strips, multi-outlet devices, or shared circuits.
- Do not connect the unit to an incorrect voltage supply or improperly sized electrical circuit.
- The electrical circuit, fuse, or circuit breaker must be properly sized for the specific model according to

# INSTALLATION

the rating label and applicable electrical codes.

- If grounding, outlet condition, circuit capacity, or electrical-code compliance is uncertain, have the outlet and circuit inspected by a qualified electrician before operation.
- Ensure the power cord is routed safely and is not pinched, crushed, sharply bent, or damaged during installation or operation.
- Allow several minutes after unplugging the unit or after a power interruption before reconnecting power to help protect the refrigeration system from short cycling.
- Use of GFI/GFCI protection may be required by local code. Where required, GFI/GFCI protection must be selected and installed by a qualified electrician. Some GFI/GFCI devices may nuisance trip with commercial refrigeration equipment. Do not bypass required electrical protection devices.
- Internal electrical service, wiring repair, control replacement, refrigeration-system service, and component replacement must be performed only by qualified service personnel.

## Clearance and Ventilation Requirements



### NOTICE!

Blocked airflow, restricted ventilation, dirty condenser surfaces, or excessive ambient temperatures may result in poor cooling performance, longer run times, refrigeration-system stress, compressor damage, product spoilage, equipment damage, or shortened equipment life.

Proper airflow is essential for normal refrigeration-system operation, beverage cooling performance, energy efficiency, and long equipment life. Restricted airflow may reduce cooling performance, increase operating temperatures and energy usage, shorten component life, or result in abnormal operation.

## Minimum Clearance Requirements

- **Rear:** 20 cm (8 in) minimum
- **Sides:** 20 cm (8 in) minimum
- **Top:** keep open and unobstructed where practical
- **Front:** keep open and unobstructed for access, dispensing, cleaning, and service

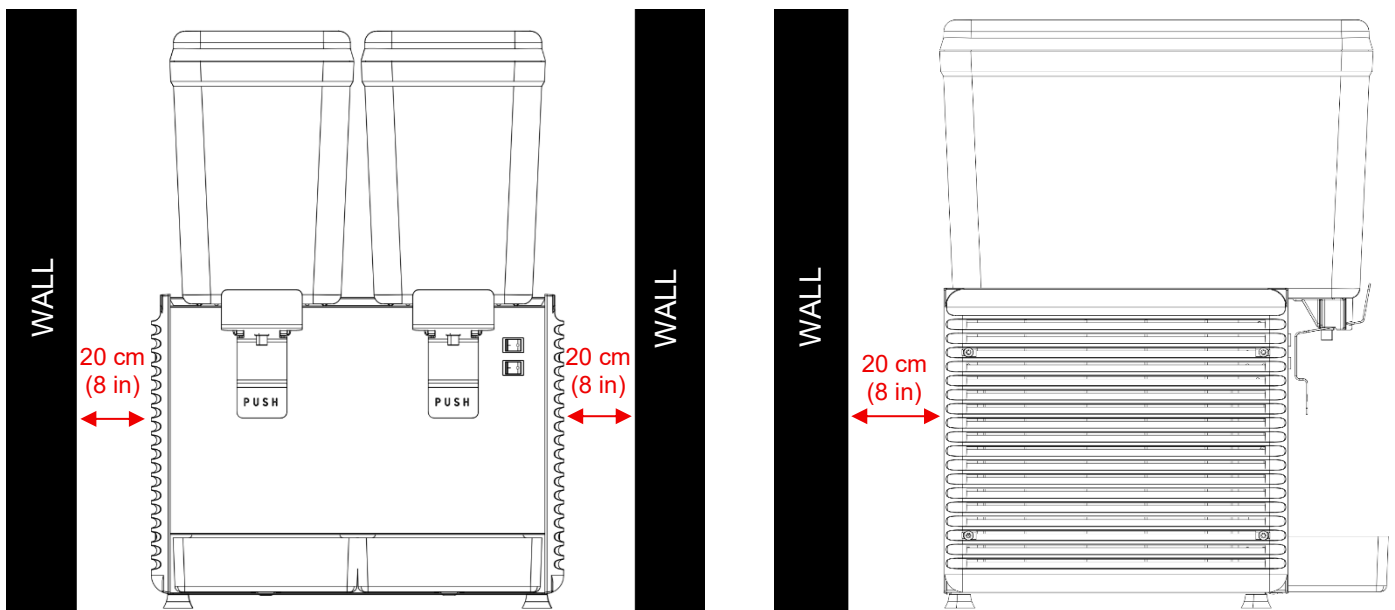

Figure A – Clearance Diagram

- Do not block, cover, or restrict condenser airflow openings on the sides or rear of the unit.
- Do not store boxes, packaging, towels, liners, filters, or other materials against airflow openings or condenser areas.
- Do not install the unit in tightly enclosed spaces with inadequate ventilation.
- Keep the surrounding installation area clean and free from dust, grease, lint, flour, and airborne debris that may restrict condenser airflow.
- Higher ambient temperatures, poor ventilation, and restricted airflow may increase cleaning frequency requirements and reduce overall performance.
- Allow sufficient space to move or access the unit for inspection, cleaning, and service when necessary.

# INSTALLATION

## Leveling, Adjustable Feet, and Optional Raised Legs



### CAUTION!

The unit becomes significantly heavier during operation when bowls are filled with beverage. Improper leveling, unstable placement, or incorrect foot or leg installation may result in product leakage, poor dispensing performance, excessive vibration, abnormal noise, equipment damage, or unsafe operating conditions.

Proper leveling is essential for stable operation, bowl seating, dispensing performance, leak prevention, and long equipment life. Operating the unit while out of level may result in beverage leakage, improper gasket sealing, abnormal agitation, increased noise, or component wear.

This unit is supplied with factory-installed adjustable feet. The adjustable feet can be raised or lowered by rotating each foot to extend or retract the threaded stem. Optional raised legs may also be supplied or available for the unit. Using the raised legs where practical is recommended to improve access for cleaning underneath the unit and to support better sanitation around the installation area.

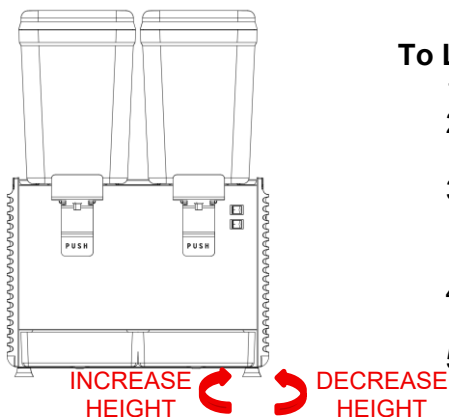

### To Level:

1. Place the unit on a stable, level countertop or support surface.
2. Confirm all feet or legs are securely installed and making firm contact with the surface.
3. Adjust the four leveling feet by rotating each foot:
  - i. Rotate clockwise to raise that corner of the unit.
  - ii. Rotate counter-clockwise to lower that corner of the unit.
4. Use a carpenter's level to verify that the unit is level front-to-back and side-to-side.
5. Confirm that the unit is stable and does not rock.

**Figure B – Adjusting the Feet**

- Keep the unit upright during movement, positioning, and leveling.
- Install only adjustable feet or raised legs supplied or approved for the unit.
- Confirm all feet or legs are securely attached, properly seated, and evenly supporting the unit before operation.
- Position unit on a stable, level surface capable of supporting unit when all bowls are filled to capacity.
- Recheck leveling after final positioning and before filling the bowls.
- Recheck leveling if the unit is moved, repositioned, relocated, or converted between adjustable feet and raised legs.
- Confirm the unit can be installed without pinching, sharply bending, or damaging the power cord.
- Confirm selected height allows required ventilation clearances, and cleaning and service access.

## Final Installation Checks

Before placing the unit into normal operation, verify the following:

- All packaging materials, tape, protective film, and shipping materials have been removed from the unit.
- The unit is installed indoors in a clean, dry, well-ventilated location.
- Required airflow clearances are maintained on all sides of the unit.
- The unit is level, stable, and does not rock during operation.
- Adjustable feet or optional raised legs are securely installed and properly supporting the unit.
- The power cord is not pinched, crushed, sharply bent, or damaged.
- The electrical supply matches the rating label requirements.
- The unit is connected to a properly grounded dedicated outlet.
- Bowls, lids, gaskets, dispensing components, drip trays, and removable parts are clean, properly assembled, and securely installed.
- All gaskets and seals are properly seated to help prevent beverage leakage.
- The unit has been cleaned and sanitized before first use following this manual.
- Operators responsible for using or cleaning the unit have reviewed the applicable sections of this manual.

## Installation and Warranty Conditions

Improper installation, incorrect electrical supply, blocked airflow, unstable placement, operation outside specified conditions, inadequate cleaning, improper reassembly, unauthorized modification, non-approved parts, or service by unqualified personnel may affect warranty coverage.

**OPERATION**

Proper operation is essential for safe use, beverage quality, sanitation, refrigeration-system performance, leak prevention, and long equipment life. Improper operation, blocked airflow, poor cleaning practices, incorrect beverage preparation, operation outside recommended conditions, or failure to follow operating instructions may result in electrical shock, product leakage, unsanitary beverage conditions, poor cooling performance, abnormal operation, equipment damage, or unsafe operating conditions.

Read and understand all operating instructions before using the unit. Operators should become familiar with the controls, normal operating sounds, beverage circulation, airflow requirements, bowl assembly, dispensing components, cleaning procedures, and safe beverage-handling practices before placing the unit into regular service.

**Components and Control Overview**

Understanding the main components and controls of the refrigerated beverage dispenser helps support proper operation, cleaning, sanitizing, leak prevention, and long equipment life.

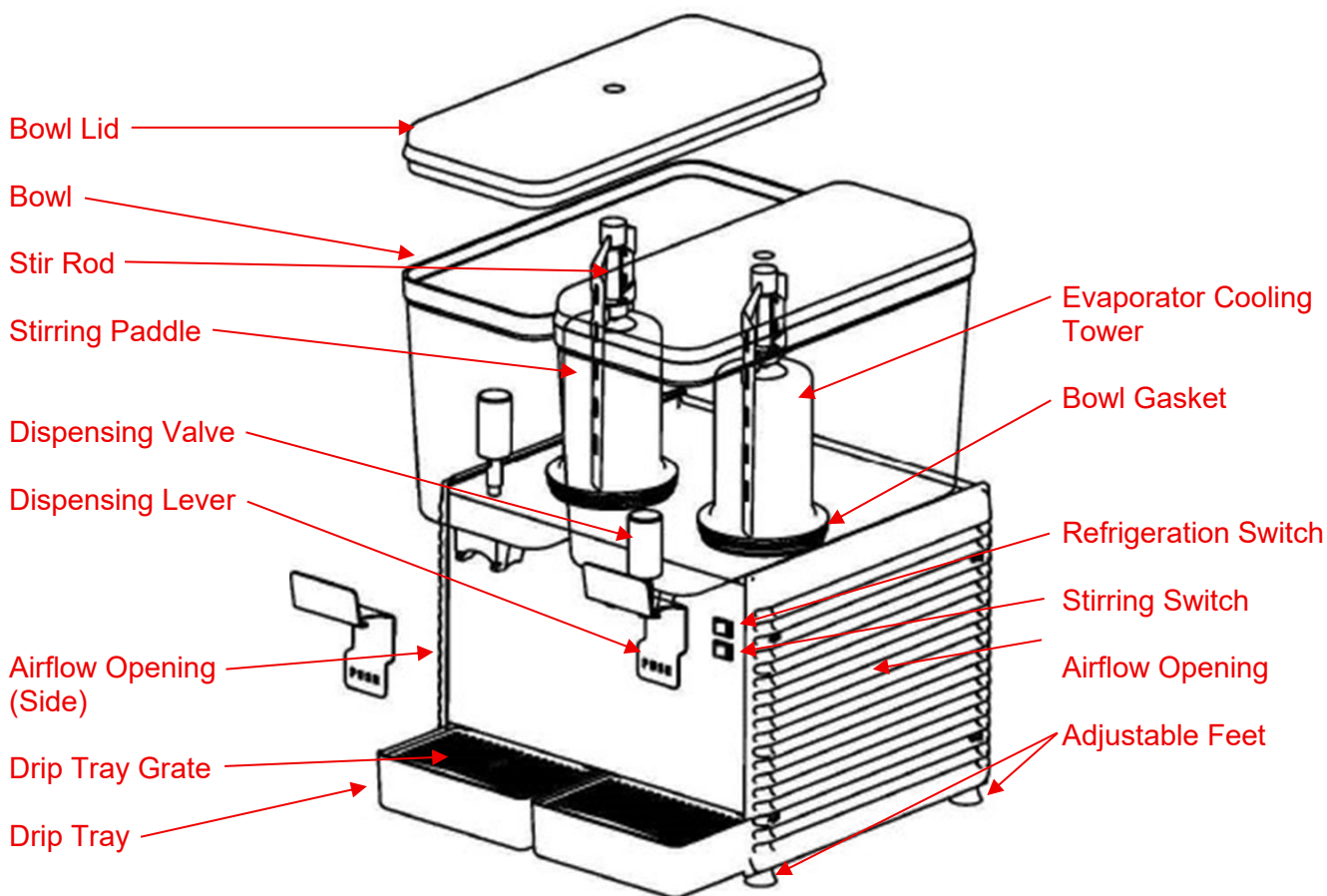

Figure C – Main Components

Component	Description
<b>Bowl Lid</b>	Covers the beverage bowl during operation to help maintain sanitation and reduce contamination.
<b>Bowl</b>	Holds the beverage product during cooling and dispensing.
<b>Stirring Paddle</b>	Circulates beverage product during operation to help maintain consistent temperature and beverage quality when the Stirring Control Switch is ON. <b>Ensure the stirring paddle is properly installed before filling the bowl.</b>
<b>Stir Rod</b>	Connects the stirring paddle to the drive system below the bowl. <b>Ensure the stir rod is properly installed before filling the bowl.</b>
<b>Evaporator Cooling Tower</b>	Provides cooling to the beverage when the Refrigeration Control Switch is ON.
<b>Bowl Gasket</b>	Seals the bowl to the cooling surface and helps prevent beverage leakage. <b>Ensure bowl gasket is properly seated and sealed around before filling the bowl with liquid.</b>
<b>Dispensing Valve and Lever</b>	Allows controlled beverage dispensing into cups or containers. Ensure the O-ring is installed properly on the dispensing valve before filling bowl with liquid.

# OPERATION

Component	Description
<b>Drip Tray</b>	Collects minor beverage drips during dispensing.
<b>Drip Tray Grate</b>	Removable grate positioned below the dispensing valve to help support cups during dispensing and allow spilled product to drain into the drip tray below.
<b>Airflow Openings</b>	Allow airflow through the refrigeration system for proper cooling performance.
<b>Adjustable Feet or Optional Raised Legs</b>	Support and level the unit during installation and operation.
<b>Refrigeration Control Switch</b>	Turns the cooling system ON or OFF. <b>Do not turn ON unless the bowl is filled to the required liquid level and the stirring system is active.</b>
<b>Stirring Control Switch</b>	Turns the stirring system ON or OFF. Keeps beverage moving inside the bowl during operation.

## Important Assembly and Leak Prevention Information

Improper bowl assembly is one of the most common causes of beverage leakage and equipment damage.

- Confirm bowl gasket is clean, undamaged, properly seated, and correctly installed before operating unit.
- Confirm the stirring paddle and stir rod are properly installed and fully seated before filling the bowl with beverage product.
- Operating the unit without the stir rod or stirring paddle correctly installed may allow liquid to leak along the stirring shaft and enter internal components, which may result in equipment damage or affected warranty coverage.
- Confirm dispensing valves, seals, and removable beverage-contact components are fully assembled and correctly installed before filling the bowls.
- If resistance, abnormal fitment, leakage, or improper seating is observed during assembly, stop and inspect components before operation.

## Front Control Switches

 <b style="font-size: 1.2em;">CAUTION!</b>	<p>Never operate the cooling system unless the stirring system is active and the bowl is filled to the required liquid level.</p> <ul style="list-style-type: none"> <li>• Operating the cooling system without stirring may cause ice buildup, poor beverage circulation, reduced cooling performance, or equipment damage.</li> <li>• Operating the cooling system with an empty bowl or low liquid level may cause ice buildup, poor performance, or equipment damage.</li> </ul>
--	--

Each unit has two rocker ON/OFF switches on the front panel:

- Cooling switch: controls the refrigeration system.
- Stirring switch: controls the stirring system inside the bowls.

Do not turn on the cooling or stirring system until beverage product or cleaning liquid is properly filled in the bowl to the required level. Operating the stirring system with no or low liquid may cause abnormal operation or component wear.

## Thermostat

The thermostat controls refrigeration temperature, which is preset to an optimum level. It is located behind the rear panel and is not intended for routine operator access or frequent adjustment.

- Do not remove the rear panel or adjust the thermostat unless qualified to do so.
- Do not adjust the thermostat to compensate for poor airflow, warm beverage product, low fill level, dirty condenser surfaces, or improper installation.
- If temperature adjustment is required, use a cleaned and sanitized food-safe thermometer to check beverage temperature in the bowl.
- The thermostat is not a precision temperature display and does not include exact temperature markings.
  - Turning the thermostat clockwise makes the setting colder.
  - Turning the thermostat counter-clockwise makes the setting warmer.
- Adjust only in small increments, then allow sufficient time for the beverage temperature to stabilize before checking again.

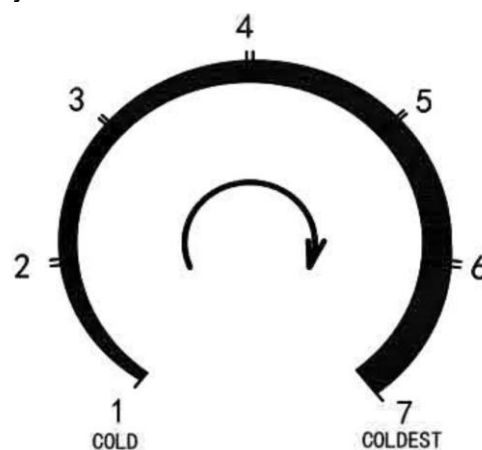

**Figure D – Thermostat Control**

## How the Refrigerated Beverage Dispenser Works

The refrigerated beverage dispenser cools and circulates beverage product inside each bowl to help maintain consistent serving temperature during commercial operation.

When the refrigeration control switch is turned ON, the refrigeration system cools the evaporator cooling tower located inside the beverage bowl. The evaporator cooling tower cools the beverage product surrounding it.

When the stirring control switch is turned ON, the stirring paddle rotates inside the bowl to continuously circulate the beverage product. Continuous circulation helps:

- maintain more consistent beverage temperature
- maintain consistent product consistency and reduce product separation
- improve cooling performance
- reduce ice buildup on the evaporator cooling tower

The stirring system and refrigeration system are designed to operate together during normal beverage service.

- Never operate the refrigeration system unless the stirring system is active and the bowl is filled to the proper liquid level.
- Operating the cooling system without beverage circulation may result in ice buildup, poor cooling performance, abnormal operation, or equipment damage.

During normal operation:

- the compressor cycles on and off automatically
- fan airflow and refrigeration sounds are normal
- beverage movement inside the bowl is normal
- condensation on cold surfaces may occur depending on room conditions, especially in humid environments.
- beverage temperature may vary temporarily after refilling with warm product

This unit is designed to run continuously, 24 hours a day, when properly installed, filled, cleaned, and maintained. During regular use, keep both the refrigeration switch and stirring switch ON overnight and during non-business hours. This helps maintain beverage temperature, keeps product circulating, and avoids repeated cooling recovery cycles.

Follow the shutdown and cleaning procedures in this manual when the unit will be emptied, cleaned, stored, or taken out of service.

## Before First Use



### CAUTION!

Do not place the unit into regular beverage service until installation, cleaning, sanitizing, reassembly, and startup checks have been completed.

Before first use:

- Confirm unit is installed, leveled, and connected according to the installation instructions in this manual.
- Confirm the unit has remained upright during transport, storage, handling, and installation. If the unit was tilted, laid on its side, front, back, or upside down, or transported non-upright, allow it to remain upright for at least 24 hours before operation.
- Clean and sanitize bowls, lids, gaskets, dispensing components, drip trays, and accessible beverage-contact surfaces according to the **Cleaning and Maintenance** section of this manual.
- Confirm bowls, lids, gaskets, dispensing components, drip trays, agitator components, and removable parts are correctly installed.
- Confirm the stirring paddle and stir rod are properly installed and fully seated before filling the bowl with beverage product. Operating the unit without these components correctly installed may allow liquid to leak along the stirring shaft and enter the motor area, which may result in equipment damage or affected warranty coverage.
- Confirm all gaskets and seals are clean, undamaged, properly seated, and correctly installed to help prevent beverage leakage.

After startup:

- Fill the bowls only after all required cleaning, sanitizing, reassembly, and inspection steps are complete.
- Check for product leakage around the bottom of each bowl, dispensing valve, gasket, and spout area after filling.
- Do not place the unit into regular service if leakage, abnormal noise, poor agitation, damaged components, or unsafe operating conditions are observed.

## Initial Startup and First Fill Check



### NOTICE!

Confirm the bowl gasket, dispensing valve, stir rod, and stirring paddle are correctly installed before filling the bowl. Incorrect assembly may allow beverage to leak from the bowl, spout, or stirring shaft area and may result in equipment damage.

Improper startup, operating with empty bowls, low liquid level, incorrectly installed components, or operating the cooling system without beverage circulation may result in beverage leakage, ice buildup, poor cooling performance, equipment damage, or unsafe operation.

Before startup:

- Confirm the unit has been properly installed, leveled, cleaned, sanitized, and assembled according to this manual.
- Confirm all bowls, lids, gaskets, dispensing components, stirring paddles, and stir rods are properly installed and correctly seated.
- Confirm refrigeration control switch and stirring control switch are both in the OFF position before filling.
- Confirm the drip trays are properly installed.
- Confirm condenser airflow openings are unobstructed.

### First Fill and Startup Procedure

1. Fill the bowls to the appropriate operating level using prepared beverage product.
2. Check for leakage around the bowl gasket, stirring shaft area, dispensing valve, and spout.
3. Turn the stirring control switch ON.
4. Confirm the stirring paddles rotate normally and beverage product circulates correctly inside the bowls.
5. Turn the refrigeration control switch ON.
6. Allow sufficient time for beverage product to cool to serving temperature before normal dispensing.

During startup:

- Cooling time will vary depending on beverage type, beverage volume, starting product temperature, room temperature, and ventilation conditions
- Warm beverage product may require extended pull-down time before reaching serving temperature
- If abnormal noise, leakage, ice buildup, poor stirring, improper cooling, or unsafe operation is observed, turn the unit OFF and inspect the installation and assembly before continuing operation.

## Beverage Preparation and Filling

Proper beverage preparation and fill-level management help support beverage quality, cooling performance, circulation, dispensing performance, sanitation, and long equipment life.

- When preparing beverage products, fully dissolve concentrates, powders, syrups, and beverage mixes according to the beverage manufacturer's instructions. Do not add dry powder or concentrated product directly into an empty bowl.
- Use clean mixing tools, clean containers, and potable water when preparing beverage product.
- Whenever practical, pre-chill beverage product before filling the bowls to reduce cooling time and improve temperature stability.
- Do not fill bowls with hot liquids.
- Do not overfill the bowls.
- Maintain the beverage level above the minimum operating level during cooling operation.
- Do not operate the refrigeration system with empty bowls or low beverage levels.
- Undissolved powders, excessive foam, pulp buildup, improper dilution, or poorly mixed products may affect cooling performance, circulation, dispensing, sanitation, or component life.
- Some beverages containing high pulp content, heavy particulates, dairy ingredients, or excessive foam may require more frequent cleaning or may not be suitable for all beverage dispenser applications.
- Follow applicable food safety requirements and beverage manufacturer instructions for product holding time, storage, refilling, and disposal.
- Do not mix fresh beverage product with old product unless allowed by the beverage manufacturer and applicable food safety requirements.

## Cooling Expectations



### NOTICE!

This equipment is designed for continuous commercial operation. During normal use, leave both the refrigeration and stirring systems ON, including overnight and during non-business hours when beverage remains in the bowls.

The refrigeration system requires time to remove heat from the beverage product. Cooling time will vary depending on product temperature, product type, fill level, ambient temperature, airflow around the unit, and operating conditions.

- Product added at room temperature will require significantly more time to cool than pre-chilled product.

## OPERATION

- For fastest cooling, pre-chill beverage products before filling the bowls whenever practical.
- Higher ambient temperatures, direct sunlight, nearby heat-producing equipment, restricted airflow, and frequent refilling with warm product will increase cooling time.
- Continuous circulation helps maintain consistent product temperature throughout the bowl and improves cooling performance.
- Maintain adequate product levels during operation. Low product levels may reduce cooling performance and increase the likelihood of product freezing on the cooling tower.
- During busy periods, frequent dispensing and refilling may temporarily increase product temperature.
- Product temperatures may vary slightly throughout the day depending on usage patterns, refill frequency, ambient conditions, and product type.

### Normal Operation

Proper operation and monitoring during daily use help support beverage quality, cooling performance, sanitation, leak prevention, and long equipment life.

- Keep beverage product above the minimum operating level at all times during operation.
- Monitor bowls, dispensing valves, gaskets, and drip trays regularly for leakage, improper assembly, or abnormal operation.
- Refill bowls using properly prepared beverage product as needed during service.
- Avoid introducing excessive foam, large amounts of warm product, or poorly mixed beverage concentrate during refill.
- Keep bowl lids installed during operation except during filling, cleaning, or inspection.
- Maintain adequate airflow around the unit during operation and keep condenser airflow openings clean and unobstructed.
- Clean spills, drips, and beverage residue promptly to help maintain sanitation and reduce sticky residue buildup.
- Follow all cleaning and sanitizing procedures in this manual.
- If the unit will be emptied, cleaned, stored, or removed from service, follow the shutdown procedures in this manual.

### Normal Operating Characteristics

The following conditions may be normal during operation:

- compressor cycling on and off
- fan airflow sounds
- beverage circulation and stirring movement inside the bowls
- mild vibration during compressor operation
- occasional clicking sounds during refrigeration cycling
- condensation on cold surfaces depending on room temperature and humidity
- temporary beverage temperature increase after refilling with warm product
- varying compressor run times depending on room temperature, ventilation conditions, beverage volume, and refill frequency

Abnormal conditions may include:

- ice formation or buildup
- beverage leakage
- poor stirring or no beverage movement
- abnormal grinding, squealing, or loud mechanical noise
- repeated breaker tripping
- failure to cool properly
- excessive condensation or water accumulation
- damaged components or abnormal vibration

If abnormal operation is observed, discontinue use and inspect the unit before continuing operation.

### Dispensing

The dispensing valve seals by allowing the valve weight to press the O-ring against the spout opening. Keep the valve and O-ring clean, correctly installed, and free of pulp, sugar residue, or damage so the valve can close properly.

- Use clean cups or containers when dispensing beverage product.
- Press the dispensing lever smoothly. Do not force, strike, or pull sharply on dispensing valve or lever.
- If product does not flow normally, stop dispensing and inspect the valve, spout, product thickness, and beverage level before continuing.
- Do not insert fingers, utensils, straws, tools, or foreign objects into the dispensing valve, spout, or bowl

during operation.

- Empty and clean drip trays regularly during service. Do not allow drip trays to overflow.
- Wipe spills promptly to reduce slip hazards, sticky buildup, and sanitation issues.
- Avoid allowing cups, pitchers, containers, or ice scoops to contact the dispensing spout. Contact with the spout may contaminate the beverage product.

## Operating Multi-Bowl Units

Multi-bowl units do not have the ability for the bowls to be operated independently. If the unit is operating, all installed bowls should be properly assembled and filled to the required operating level.

- Do not operate the unit with any empty bowl.
- Do not allow any bowl to run below the minimum operating level while the unit is operating.
- If only one beverage flavour is being served, fill the other bowl or bowls with clean potable water to the required operating level.
- Confirm the stir rod and stirring paddle are correctly installed in every bowl before filling.
- Keep lids installed on all bowls during operation.
- Clean, sanitize, rinse, and dry unused bowls before returning them to beverage service.
- Replace water in non-beverage bowls regularly and clean the bowls as part of normal daily cleaning.

For best performance and to avoid equipment damage, all bowls should contain beverage product or clean potable water whenever the refrigeration and stirring systems are operating.

## Shutdown Procedure

This unit is designed for continuous 24-hour commercial operation during normal use. During regular operation, the refrigeration control switch and stirring control switch should normally remain ON, including overnight and during non-business hours.

Shutdown procedures should be followed when:

- the unit will be emptied or cleaned
- beverage product will not be used for an extended period
- the unit will be stored, moved, or removed from service
- sanitation procedures require full shutdown
- maintenance or inspection is required

To shut down the unit:

1. Turn the refrigeration control switch OFF.
2. Turn the stirring control switch OFF.
3. Disconnect power if cleaning, maintenance, or extended shutdown will be performed.
4. Drain or dispense beverage product from the bowls.
5. Clean and sanitize all bowls, lids, gaskets, dispensing components, drip trays, stirring paddles, stir rods, and beverage-contact surfaces according to the **Cleaning and Maintenance** section.
6. Rinse and dry components thoroughly before reassembly or storage.
7. Leave bowls empty during extended shutdown or storage periods.

Do not leave beverage product inside the bowls during extended shutdown or storage. Follow applicable food safety requirements for beverage disposal after extended holding periods.

After cleaning, sanitizing, or extended shutdown, inspect all gaskets, stirring components, and dispensing components before returning the unit to service. Follow the startup procedures in this manual before resuming normal operation.

## CLEANING AND MAINTENANCE

Proper cleaning, sanitizing, inspection, and preventive maintenance are essential for beverage quality, sanitation, cooling performance, reliable dispensing, leak prevention, and long equipment life. Failure to maintain the unit properly may result in beverage contamination, residue buildup, restricted airflow, beverage leakage, poor cooling performance, abnormal operation, component wear, equipment damage, or unsafe operating conditions.

### Cleaning and Maintenance Safety



#### WARNING!

Failure to disconnect power, follow proper cleaning procedures, or use appropriate cleaning chemicals may result in electrical shock, contamination, equipment damage, serious injury, or unsafe operating conditions.

- Turn both the refrigeration control switch and stirring control switch OFF and disconnect the power cord before cleaning, inspection, maintenance, movement, or service.
- Always grasp the plug firmly when disconnecting power. Do not pull on the power cord.
- Do not clean the unit while energized or while moving components remain in operation.
- Do not immerse the unit, power cord, plug, or electrical components in water or any other liquid.
- Do not spray, hose down, pressure clean, or steam clean the unit.
- Do not allow water, cleaning chemicals, sanitizer, beverage residue, or debris to enter electrical areas, controls, airflow openings, fan areas, or refrigeration components.
- Use caution when cleaning around evaporator cooling towers, stirring components, dispensing valves, sheet metal edges, and condenser airflow areas.
- Sheet metal edges may be sharp. Avoid direct contact.
- Use only cleaning and sanitizing products suitable for commercial beverage equipment and food-contact surfaces.
- Confirm bowls, gaskets, dispensing valves, stirring paddles, stir rods, and removable components are correctly installed after cleaning and before refilling the unit.
- If the unit has been exposed to flooding, excessive water intrusion, damaged wiring, or refrigeration-system damage, discontinue use and contact qualified service personnel before reconnecting power.
- Internal electrical service, refrigeration-system service, controller replacement, wiring repair, and component replacement must be performed only by qualified service personnel.

### Cleaning, Sanitizing, and Reassembly Procedure



#### CAUTION!

Improper chemical handling, mixing incompatible chemicals, excessive sanitizer concentration, or failure to follow chemical manufacturer instructions may result in toxic fumes, contamination, equipment damage, chemical injury, or unsafe operating conditions.



#### CAUTION!

Never mix sanitizer or sanitizing solution with acids, chlorine products, or other cleaning chemicals.

### Before Cleaning



#### WARNING!

Disconnect the unit from the power supply before cleaning. Failure to disconnect power may result in electric shock.

1. Turn the refrigeration control switch OFF.
2. Turn the stirring control switch OFF.
3. Disconnect the power cord from the electrical outlet.
4. Allow cold surfaces to stabilize before disassembly and cleaning.

Do not begin disassembly or cleaning while moving components remain in operation.

### Cleaning Procedure



#### WARNING!

Do not immerse the base section, electrical components, power cord, or refrigeration components in water or any other liquid.

1. Remove the bowl lid and drain excess product. Fill the bowl with warm water and flush through the dispensing valve until clear water flows from the spout.
  - i. Do not remove the stir rod or stirring paddle before flushing the bowl with warm water. These components must remain installed while filling the bowl with water or beverage.
2. Remove the white stirrer and centre shaft by lifting upward. No tools are required for removal.
3. Remove the top part of the dispensing valve assembly while holding the dispensing lever. The pieces will separate and can be removed.

## CLEANING AND MAINTENANCE

4. Remove the bowl by lifting it up and over the evaporator cooling tower.
5. Remove the bowl gasket. Wash the bowl with warm water and mild detergent, then rinse with clean water. Do not place the bowl in a dishwasher or use harsh chemicals. After rinsing, apply a light coating of food-grade grease lubricant to the gasket, then reinstall the gasket on the bowl base.
6. Remove the O-ring from the dispensing valve, then wash and rinse both parts separately. After rinsing, apply a light coating of food-grade grease lubricant to the dispensing valve O-ring, then reinstall the O-ring on the dispensing valve.
7. Wipe down the evaporator cooling tower with a clean, damp cloth.
8. Remove the drip tray and drip tray grate. Pour out any excess product and wash both parts with warm water and mild detergent. Use a soft cloth, sponge, or soft brush to remove sticky or dried beverage residue from the tray, grate, corners, grooves, and edges. Rinse thoroughly, dry, and reinstall the drip tray grate.

Do not use steel wool, abrasive pads, sharp tools, highly corrosive cleaners, or aggressive chemicals on bowls, gaskets, dispensing components, or stainless steel surfaces.

### Re-Assembly Procedure

Improper reassembly is one of the most common causes of beverage leakage, poor dispensing performance, and equipment damage. Confirm all components are clean, correctly installed, and properly seated before filling the bowls or returning the unit to service.

1. Place the bowl onto the base. Confirm the lubricated gasket is properly installed and seated in position. When properly installed, the bowl should sit flat and stable on the base without rocking or gaps.
2. Install the dispensing valve through the hole in the bowl. Attach the dispensing lever using the dispensing valve to secure the dispensing assembly.
3. Push the stir rod into place. Place the stirring paddle over the stir rod and push downward until fully seated.



#### CAUTION!

Operating the unit without the stir rod or stirring paddle correctly installed may allow beverage to leak along the stirring shaft and enter internal components, which may result in equipment damage.

4. Install the bowl lid.
5. Reinstall the drip tray and drip tray grate.
6. After reassembly and filling, check around the bowl gasket, dispensing valve, spout, and stirring shaft area for leakage before returning the unit to normal service.

### Sanitizing Procedure



#### CAUTION!

Residual sanitizing solution left inside the unit may create a health hazard.



#### CAUTION!

Do not soak dispensing valves, O-rings, gaskets, or seals in chlorine solution overnight. Extended chemical exposure may cause swelling, deterioration, leakage, or component damage.

Sanitize the unit after cleaning, before first use, after extended shutdown, whenever beverage product is changed, or whenever contamination or unsanitary conditions may exist.

1. Prepare an approved food-safe sanitizing solution according to the sanitizer manufacturer's instructions.
2. Fill each bowl to the upper fill level with sanitizing solution containing a minimum of 100 ppm available chlorine and not more than 200 ppm available chlorine.
3. Allow the sanitizing solution to remain in the bowls according to sanitizer manufacturer's instructions, or at least five (5) minutes.
4. Turn the stirring control switch ON and allow the sanitizer solution to circulate inside the bowls for the sanitizer manufacturer's recommended contact time, but not less than 90 seconds.
5. Drain the sanitizer completely through the dispensing valves and spouts.
6. Rinse the bowls, dispensing components, and beverage-contact surfaces thoroughly using clean potable water several times to help remove sanitizer residue.
7. Wipe remaining moisture from exterior surfaces and allow cleaned components to air dry where appropriate before reassembly or refilling.

When sanitizing the unit:

- Follow all sanitizer manufacturer instructions regarding concentration, contact time, handling, rinsing, and disposal.
- Use clean containers, utensils, and mixing tools during sanitizing procedures.
- For hard water locations or persistent residue buildup, consult local sanitation or water-treatment

guidance.

- After sanitizing and reassembly, inspect carefully for leakage before returning the unit to normal beverage service.

## Exterior Cleaning

Regular exterior cleaning helps maintain appearance, sanitation, airflow, and long-term equipment condition. Prompt removal of beverage spills, sugar residue, and product buildup will help reduce staining, sticky surfaces, corrosion, and difficult cleaning later.

- Wipe exterior surfaces regularly using a soft cloth and warm water or a mild food-safe detergent.
- Clean spills, splashes, sugar residue, syrup residue, fingerprints, and product buildup promptly.
- Clean the front panel and control-switch area using a damp cloth. Do not allow water or cleaning solution to enter switches, electrical components, or ventilation openings.
- Clean stainless steel surfaces using a soft cloth and a cleaner suitable for stainless steel.
- Always wipe stainless steel surfaces in the direction of the grain whenever possible.
- Rinse away any cleaner residue and dry stainless steel surfaces after cleaning.
- Do not use steel wool, wire brushes, abrasive pads, powdered cleaners, bleach, chlorine-based cleaners, or highly corrosive chemicals on stainless steel surfaces.
- Do not use knives, scrapers, or sharp tools to remove dried residue from painted, plastic, or stainless steel surfaces.
- Do not spray, hose down, pressure wash, or steam clean the exterior of the unit.
- Do not allow water, cleaning chemicals, or beverage residue to enter ventilation openings, condenser areas, switches, wiring compartments, or electrical components.
- Keep ventilation openings clean and unobstructed to maintain proper airflow and cooling performance.

After cleaning, dry all exterior surfaces thoroughly before returning the unit to normal operation.

## Condenser Cleaning



### WARNING!

Disconnect the unit from the power supply before removing panels or cleaning the condenser area. Failure to disconnect power may result in electrical shock, injury, or equipment damage.



### CAUTION!

Condenser fins may be sharp and can bend easily. Use caution when cleaning around the condenser coil. Damaged fins may reduce airflow and cooling performance or cause injury.

A dirty or blocked condenser reduces airflow, increases operating temperature, reduces cooling performance, increases energy consumption, and may shorten component life. Failure to maintain the condenser may contribute to service issues and may affect warranty coverage. Inspect the condenser regularly and clean it whenever dust, lint, grease, sugar residue, or debris is visible.

Under normal commercial use, the condenser should be cleaned at least monthly. More frequent cleaning may be required in dusty, greasy, high-temperature, or high-use environments.

Perform condenser cleaning only when the unit is empty of beverage product and normal beverage service has been stopped. Condenser cleaning should be performed during scheduled cleaning or maintenance periods.

## Cleaning Procedure:

1. Turn the refrigeration control switch OFF.
2. Turn the stirring control switch OFF.
3. Disconnect the power cord from the electrical outlet.
4. Remove the screws from the left side panel while facing the front of the machine.
5. Remove the side panel carefully.
6. Locate the condenser coil behind the panel.
7. Using a vacuum cleaner with a soft brush attachment, gently remove dust, lint, grease, sugar residue, and debris from the condenser surface.
8. Brush vertically up and down across the fins. Do not brush left to right, as this may damage the condenser fins.
9. Avoid excessive force while cleaning. Do not use sharp tools, metal brushes, high-pressure air, or liquid cleaners on the condenser coil.
10. Inspect the condenser for damaged fins, heavy buildup, blockage, or abnormal debris accumulation.
11. Reinstall the side panel and secure it using the screws.
12. Reconnect power and return the unit to normal operation.

# CLEANING AND MAINTENANCE

After cleaning, confirm:

- the condenser airflow openings are unobstructed
- the side panel is securely installed
- no wiring was disturbed or damaged
- the unit operates normally after restart

If the condenser is heavily clogged, damaged, or cannot be cleaned using normal operator-level cleaning, contact qualified service personnel.

## Preventive Maintenance and Service Boundary

Operator-level maintenance includes:

- cleaning and sanitizing bowls, lids, gaskets, dispensing components, drip trays, stirring paddles, and stir rods
- cleaning exterior surfaces and stainless steel panels
- cleaning condenser surfaces as described in this manual
- inspecting gaskets, O-rings, dispensing valves, stirring components, bowls, lids, and drip trays for wear, damage, residue buildup, or improper fitment
- confirming the unit is level, properly ventilated, correctly assembled, and operating normally

Internal electrical repair, thermostat service, switch replacement, stirring motor service, fan service, compressor service, sealed refrigeration-system service, refrigerant handling, wiring repair, internal diagnostics, panel-off service work beyond condenser cleaning, and internal disassembly must be performed only by qualified service personnel.

Improper servicing, unauthorized repair, modification, use of non-approved parts, or internal service by unqualified personnel may result in electrical shock, refrigerant exposure, product leakage, contamination, equipment damage, unsafe operation, or affected warranty coverage.

## Recommended Cleaning and Maintenance Schedule

Regular cleaning and preventive maintenance are required to maintain beverage quality, sanitation, cooling performance, reliable dispensing, leak prevention, airflow, and long equipment life. Cleaning frequency depends on beverage type, sugar content, pulp content, dairy content, ambient conditions, installation environment, and operating usage.

Beverage residue, dried sugar, pulp buildup, dirty gaskets, worn O-rings, restricted airflow, dirty condenser surfaces, and incorrect reassembly may reduce performance and increase the likelihood of leakage, poor circulation, poor cooling, sanitation issues, or service problems.

The following schedule is a general guideline. More frequent cleaning may be required when using dairy products, high-sugar beverages, pulpy beverages, foaming beverages, high-volume operation, high-temperature kitchens, greasy environments, or areas with airborne dust or debris.

Component / Area	Recommended Frequency	Operator Guidance
<b>Beverage bowls and lids</b>	Daily	Drain product, wash with warm water and mild detergent, rinse thoroughly, sanitize, and inspect for cracks or residue buildup.
<b>Dispensing valves and spouts</b>	Daily	Remove, wash, rinse, sanitize, and inspect for sticky residue, pulp, worn O-rings, or leakage.
<b>Stirring paddles and stir rods</b>	Daily	Remove, wash, rinse, sanitize, and confirm each part is clean, undamaged, and correctly reinstalled before filling bowls.
<b>Bowl gaskets</b>	Daily	Remove, wash, rinse, inspect for wear or twisting, apply light food-grade lubricant as required, and confirm proper seating during reassembly.
<b>Drip trays and drip tray grates</b>	Daily or more often as needed	Empty, wash, rinse, dry, and reinstall. Clean sticky residue from corners, grooves, and edges.
<b>Exterior surfaces</b>	Daily	Wipe spills, splashes, fingerprints, and beverage residue with a soft cloth and mild detergent. Dry thoroughly.
<b>Stainless steel front and side panels</b>	Daily to weekly	Clean with a soft cloth in the direction of the grain. Do not use steel wool, bleach, chlorine cleaners, or abrasive pads.
<b>Full cleaning and sanitizing</b>	Daily during regular use	Complete bowl, gasket, dispensing valve, stirring component, drip tray, and food-contact surface cleaning and sanitizing.
<b>Deep cleaning</b>	Weekly	Perform full disassembly cleaning, inspect all beverage-contact parts, remove dried residue, and verify proper reassembly.
<b>Condenser inspection</b>	Monthly	Check condenser area for dust, lint, grease, flour, sugar residue, or blocked airflow.



## TROUBLESHOOTING GUIDE

If the unit does not appear to be operating correctly, review the **Installation, Operation, Cleaning and Maintenance**, and **Shutdown Procedure** sections first. Many apparent problems are caused by restricted airflow, improper cleaning, incorrect reassembly, dirty gaskets, worn O-rings, blocked dispensing components, low beverage level, warm product, unsuitable beverage type, environmental conditions, improper startup procedures, or cleaning-related conditions and may often be corrected without service.

Use the guide below to identify common symptoms, likely causes, and recommended corrective actions. If the issue persists after completing the recommended steps, discontinue use and contact qualified service personnel.



### WARNING!

If the issue involves smoke, burning odour, overheating, damaged power cord or plug, repeated breaker tripping, sparking, electrical shock risk, liquid entering electrical areas, damaged refrigeration tubing, suspected refrigerant leakage, or any other unsafe condition, disconnect power if safe to do so and do not resume operation until the problem is corrected.



### WARNING!

Disconnect power before inspection, cleaning, or maintenance. Do not attempt to bypass controls, remove panels except as instructed for operator-level condenser cleaning, service sealed refrigeration components, or perform internal electrical repairs unless qualified to do so.

### Before Calling for Service

Before troubleshooting specific issues, confirm the following:

- The unit is connected to a properly grounded outlet matching the rating label requirements.
- The outlet has power and the circuit breaker has not tripped.
- The power cord and plug are undamaged and fully connected.
- The unit has been installed with all required airflow clearances maintained.
- The condenser and airflow openings are clean and unobstructed.
- The ambient temperature is within the recommended operating range.
- The unit is installed away from major heat sources and direct sunlight.
- The bowls are filled above the minimum operating level and are not overfilled.
- Beverage product was properly mixed before filling the bowls.
- Beverage product is suitable for refrigerated beverage dispenser operation.
- Both the stirring control switch and refrigeration control switch are ON during normal operation.
- The stirring paddles rotate normally and beverage product circulates correctly.
- Bowls, gaskets, dispensing valves, O-rings, stir rods, and stirring paddles are correctly installed.
- Gaskets and O-rings are clean, undamaged, lubricated where required, and properly seated.
- Drip trays are installed and not overflowing.
- The unit has been cleaned and sanitized according to this manual.
- Beverage residue, pulp buildup, dried sugar, or sticky deposits are not restricting movement, sealing, or dispensing.
- The unit has completed normal startup and sufficient time has been allowed for beverage cooling.

Symptom	Possible Cause	Operator Action
<b>Electrical / Power</b>		
<b>Unit has no power</b>	Power cord unplugged, outlet has no power, breaker tripped, incorrect electrical supply, damaged cord or plug	Confirm plug is fully connected, outlet has power, and breaker has not tripped. Verify outlet matches rating label. Do not use if cord, plug, or outlet is damaged.
<b>Breaker trips repeatedly</b>	Overloaded circuit, shared outlet, extension cord, moisture intrusion, damaged wiring, or internal electrical fault	Stop use. Disconnect power if safe. Remove extension cords, adapters, outlet splitters, or power strips. If breaker trips again, contact qualified service personnel.
<b>Power cord, plug, or outlet is hot, loose, damaged, or discoloured</b>	Damaged electrical connection, poor outlet contact, overloaded circuit, or electrical fault	Stop use immediately. Disconnect power if safe. Do not operate until inspected and corrected by qualified personnel.
<b>Startup / Operation</b>		
<b>Unit was turned on before bowls were filled</b>	Refrigeration or stirring activated without liquid in bowls	Turn unit OFF. Fill bowls to the proper level before restarting.

## TROUBLESHOOTING GUIDE

Symptom	Possible Cause	Operator Action
<b>One bowl is empty while unit is running</b>	Empty bowl operated with refrigeration or stirring active	Do not operate empty bowls. Fill bowls before operation.
<b>Unit cools poorly after being shut off overnight</b>	Unit was powered off instead of left in normal operating mode	Leave refrigeration and stirring switches ON during normal operation when beverage remains in the bowls.
<b>Cooling / Refrigeration</b>		
<b>Unit does not cool</b>	Refrigeration switch OFF, no power, thermostat issue, dirty condenser, blocked airflow, compressor/fan/refrigeration fault	Confirm power, switch position, clearances, airflow openings, condenser cleanliness, and ambient temperature. Contact service if cooling does not begin.
<b>Beverage takes too long to cool</b>	Warm product added, high ambient temperature, blocked airflow, dirty condenser, poor stirring, product too thick, or insufficient cooling time	Use pre-chilled product where practical. Confirm airflow, condenser cleanliness, proper stirring, and allow sufficient cooling time.
<b>Cooling performance poor during busy service</b>	Frequent refilling with warm product, low product level, high room temperature, direct sunlight, nearby heat source, or restricted airflow	Pre-chill refills, maintain proper fill level, keep lids installed, improve airflow, and clean condenser.
<b>Compressor runs continuously</b>	Dirty condenser, blocked airflow, hot room, warm product, overfilled bowls, poor stirring, or refrigeration fault	Clean condenser, improve airflow, verify stirring operation, and confirm ambient conditions.
<b>Side or rear panels feel warm</b>	Normal heat rejection, restricted airflow, dirty condenser, or nearby heat source	Some warmth is normal. Confirm required clearances and clean condenser if necessary.
<b>Unit cools one day but poorly the next</b>	Dirty condenser, room temperature change, warm refill product, blocked airflow, product difference, or overnight shutdown	Check airflow, condenser cleanliness, fill level, and product temperature.
<b>Fan runs but unit does not cool</b>	Compressor, thermostat, relay, refrigeration system, or internal electrical issue	Confirm condenser is clean and airflow is unobstructed. Contact qualified service personnel.
<b>Product too cold or freezing</b>	Thermostat set too cold, low liquid level, stirring OFF, poor circulation, product too thin, or low ambient temperature	Maintain proper fill level and stirring operation. Allow ice to melt. Contact service if freezing continues.
<b>Thermostat adjustment does not solve temperature issue</b>	Poor airflow, dirty condenser, warm product, low fill level, unsuitable product, or service fault	Correct airflow, condenser, fill level, product, and stirring issues first.
<b>Stirring / Circulation</b>		
<b>Ice forms on evaporator cooling tower</b>	Low beverage level, stirring system OFF, stir rod or paddle missing, product too thick, thermostat too cold, or poor circulation	Turn refrigeration OFF and allow ice to melt. Correct the cause before restarting.
<b>Beverage does not circulate or stir properly</b>	Stirring switch OFF, missing or incorrectly installed stir rod/paddle, sticky residue, thick product, worn part, or motor fault	Confirm switch position, clean and reinstall components, and verify product suitability.
<b>Stirring paddle chatters, binds, or makes abnormal noise</b>	Low liquid level, empty bowl, sticky buildup, incorrect installation, worn part, or dry operation	Do not run dry. Clean, refill, and verify correct installation.
<b>One bowl performs differently from another</b>	Assembly difference, stirring issue, product difference, fill-level difference, gasket issue, or cooling difference	Compare assembly, fill levels, product type, and stirring operation between bowls.
<b>Stirring works in one bowl but not another</b>	Incorrect assembly, sticky residue, damaged stir rod, damaged stirring paddle, worn component, product too thick, low liquid level, or internal drive issue	Clean and reinstall components in the affected bowl. Confirm fill level and product consistency. Contact qualified service personnel if the issue continues.
<b>Stirring paddle stops after product thickens</b>	Product viscosity increased, sugar/pulp buildup, low liquid level, or worn component	Clean components, correct product consistency, and maintain proper fill level.
<b>Leakage / Dripping / Condensation</b>		
<b>Beverage leaks from bottom of bowl</b>	Bowl gasket dirty, twisted, dry, worn, damaged, incorrectly seated, or bowl not fully seated	Clean, inspect, lubricate if required, and reinstall gasket and bowl correctly.
<b>Beverage leaks from dispensing valve or spout</b>	O-ring dirty, twisted, worn, cut, missing, or valve incorrectly assembled	Clean, inspect, and reinstall valve components. Replace damaged parts.

## TROUBLESHOOTING GUIDE

Symptom	Possible Cause	Operator Action
<b>Beverage leaks near stirring shaft area</b>	Stir rod or stirring paddle missing, incorrectly installed, or sealing area contaminated	Clean and correctly reinstall stirring components before refilling.
<b>Leak appears immediately after cleaning</b>	Gasket, O-ring, valve, bowl, stir rod, or paddle incorrectly reinstalled	Disassemble, inspect, clean, and reassemble correctly.
<b>Valve drips after dispensing</b>	Dirty valve, sticky syrup residue, worn O-ring, damaged seal, or pulp trapped in valve	Clean valve assembly and inspect seals.
<b>Liquid collects under unit</b>	Overflowing drip tray, bowl leak, valve leak, condensation, spill, or cleaning water	Identify source, dry area, and inspect all leak points.
<b>Drip tray overflows</b>	Tray full, improperly installed, excessive dripping, or heavy condensation	Empty, clean, and reinstall tray. Investigate source if recurring.
<b>Excessive condensation on bowls</b>	High humidity, warm room, frequent lid removal, warm product, or normal condensation	Improve room conditions, keep lids installed, and verify leakage is not being mistaken for condensation.
<b>Beverage Quality / Dispensing</b>		
<b>Beverage has poor taste, odour, or residue</b>	Insufficient cleaning, sanitizer residue, old product, dirty components, or poor-quality ingredients	Discard product. Clean, rinse, sanitize, and refill with fresh product.
<b>Beverage separates, foams, or dispenses poorly</b>	Product not mixed completely, excessive foam, high pulp, heavy particulates, dairy content, or incorrect dilution	Prepare product correctly and verify suitability for beverage-dispenser use.
<b>Product is too thick to circulate</b>	Incorrect dilution, concentrate too strong, heavy syrup, pulp, or unsuitable product	Adjust product according to beverage manufacturer recommendations.
<b>Foam builds up in bowl</b>	Product foams during circulation, overfilled bowl, aggressive mixing, or unsuitable product	Reduce foam before filling and avoid overfilling.
<b>Product splashes or circulates aggressively</b>	Overfilled bowl, incorrect stir component installation, low liquid level, or foaming product	Correct fill level and verify stirring-component installation.
<b>Product becomes warm near top of bowl</b>	Poor circulation, low fill level, thick product, stirring OFF, or frequent lid removal	Confirm proper circulation and maintain fill level.
<b>Dispensing is slow or restricted</b>	Sticky residue, pulp buildup, valve obstruction, product too thick, dirty spout, or damaged valve component	Clean dispensing components and verify product suitability.
<b>Cleaning / Sanitation</b>		
<b>Sticky buildup returns quickly</b>	High-sugar product, inadequate cleaning, poor rinsing, or residue left behind	Increase cleaning frequency and improve cleaning thoroughness.
<b>Mould, odour, or slime appears</b>	Product held too long, inadequate cleaning, poor drying, or old residue	Discard product and perform complete cleaning and sanitizing procedure.
<b>Sanitizer smell or taste remains</b>	Improper rinsing, excessive sanitizer concentration, or sanitizer not drained completely	Rinse thoroughly and prepare fresh product.
<b>Noise / Vibration</b>		
<b>Unit is noisy or vibrating</b>	Unit not level, loose panel, incorrect assembly, low product level, damaged component, fan issue, or compressor vibration	Confirm level installation, proper assembly, and adequate product level.
<b>Chattering sound from bowl area</b>	Stirring paddle running dry, low liquid level, worn component, or incorrect installation	Fill bowl, clean components, and verify installation.
<b>Fan scraping or rubbing sound</b>	Fan obstruction, bent fan blade, loose panel, or service issue	Check for obvious external obstruction. Contact service if condition persists.

### When to Stop and Call for Service

Stop using the unit, turn both the refrigeration control switch and stirring control switch OFF, disconnect power from the electrical outlet, and contact qualified service personnel if any of the following occur:

- Circuit breaker trips repeatedly or the unit repeatedly loses power during operation.
- Power cord, plug, receptacle, control switches, panels, bowls, dispensing valves, gaskets, stirring components, or housing becomes damaged, loose, unsafe, or abnormal.
- Electrical odour, smoke, sparks, arcing, overheating, burning smell, or electrical shock risk is observed.
- Liquid enters electrical areas, control-switch areas, wiring compartments, motor areas, fan areas, or internal components.
- Refrigerant tubing appears damaged, crushed, leaking, heavily corroded, or a refrigerant leak is suspected.

## TROUBLESHOOTING GUIDE

- Unit overheats, shuts down unexpectedly, or continues to operate abnormally after airflow, condenser, ambient temperature, fill level, and cleaning checks.
- Unit does not cool after confirming proper power, switch operation, airflow clearance, condenser cleanliness, ambient conditions, fill level, and stirring operation.
- Fan, compressor, thermostat, stirring motor, control switch, or internal electrical operation appears abnormal after normal operator checks.
- Stirring system does not operate after confirming correct switch position, proper stir rod and stirring paddle installation, clean components, and suitable beverage consistency.
- Beverage leakage continues after draining, cleaning, inspecting, lubricating where required, and correctly reinstalling gaskets, O-rings, bowls, dispensing valves, stir rods, and stirring paddles.
- Ice buildup or product freezing continues after correcting liquid level, stirring operation, product consistency, airflow, condenser cleanliness, and ambient conditions.
- Product develops persistent unusual odour, taste, discolouration, residue, mould, slime, or contamination concerns after cleaning, sanitizing, rinsing, and replacing product.
- Abnormal grinding, scraping, severe vibration, fan rubbing, loud mechanical noise, or unsafe movement continues after leveling, reassembly, and operator-level checks.
- Unit has been dropped, impacted, tipped, exposed to flooding, exposed to freezing conditions, or liquid has entered electrical or internal areas.
- Bowl, dispensing valve, gasket, O-ring, stir rod, stirring paddle, control switch, panel, condenser, fan area, or internal component becomes damaged, cracked, loose, obstructed, worn, or unsafe.
- Internal electrical service, thermostat replacement, control switch replacement, stirring motor service, fan service, sealed refrigeration-system service, refrigerant handling, compressor service, wiring repair, or internal disassembly is required.

Do not attempt to repair internal electrical, refrigeration, control, wiring, motor, fan, compressor, or sealed-system components unless qualified. Unauthorized repair, modification, bypassing controls, or use of non-approved parts may result in injury, electrical shock, refrigerant hazard, product leakage, contamination, equipment damage, unsafe operation, or affected warranty coverage.

## CIRCUIT DIAGRAM

The circuit diagram is provided for reference by qualified service personnel only. It is not intended for operator troubleshooting, repair, modification, or internal electrical service.



### WARNING!

Electrical service, wiring repair, switch or thermostat replacement, stirring motor, fan, compressor, or refrigeration-system service, refrigerant handling, and electrical diagnostics must be performed only by qualified service personnel.

- Operators must not remove panels except as specifically instructed for operator-level condenser cleaning, access internal electrical components, bypass controls, modify wiring, replace internal components, or attempt electrical repair.
- Disconnect power before inspection, wiring verification, servicing, or electrical repair.
- Do not operate the unit with panels removed, wiring exposed, damaged electrical components, damaged refrigeration components, or missing safety covers.
- Use the correct circuit diagram for the specific model being serviced. Always refer to the unit rating label and actual component configuration before performing service.
- Verify the model number and serial number before ordering parts, diagnosing electrical issues, or performing service work.
- Replacement components must meet the specifications of the original equipment and be suitable for the specific model being serviced.

The circuit diagram is intended solely as a service reference and does not provide step-by-step repair instructions.

### DISP1, DISP1S, NBD1, NBD1SS

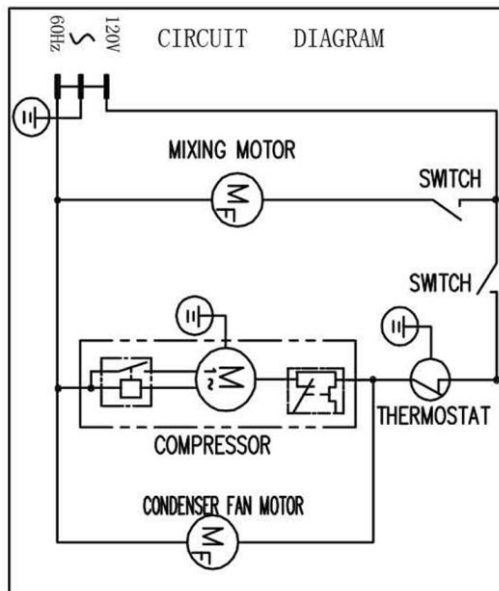

### DISP2, DISP2S, NBD2, NBD2SS

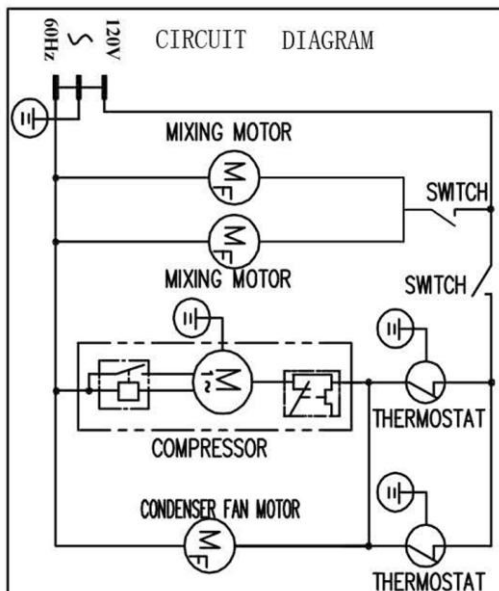

### DISP3, DISP3S, NBD3, NBD3SS

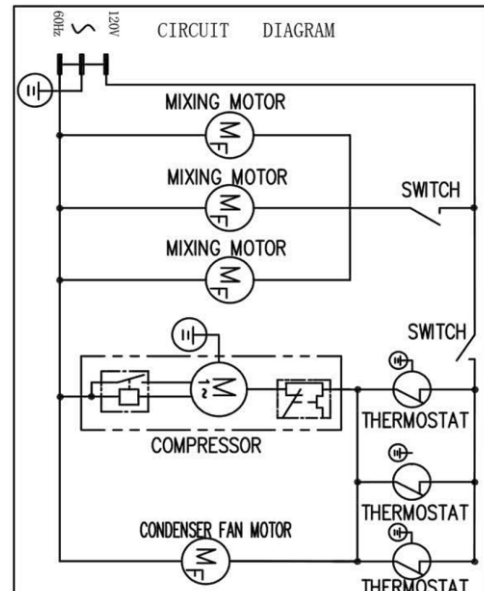

## WARRANTY, SERVICE, AND SPARE PARTS

### Warranty

For full warranty terms, conditions, limitations, and exclusions, please visit:

<https://noriota.ca/pages/warranty-policy>

To register your product online, visit:

<https://noriota.ca/pages/warranty-registration>

Please have your model number and serial number available when registering your product or requesting warranty support.

Scan to register your product online:



### Spare Parts

Replacement parts diagrams and component identification resources are available at:

[www.noriota.ca](http://www.noriota.ca)

Search by model number and verify the model and serial number before ordering parts. Use only approved replacement parts intended for this model. Parts diagrams are for identification only and do not replace qualified service procedures.

### Rating Label Information

The rating label is located on the unit in a visible service-access location. The exact location may vary by model. The rating label contains important technical and identification information, including:

- Model number
- Serial number
- Electrical rating
- Voltage
- Frequency
- Power consumption
- Refrigerant type and charge
- Certification information, including applicable safety and sanitation standards

Always verify that the electrical supply matches the requirements shown on the rating label before operation.

Do not remove, cover, deface, paint over, or damage the rating label. The rating label must remain legible for the life of the equipment.

**COMMISSIONING RECORD**

Record the information below at the time of installation. This record helps confirm proper installation conditions, supports future service, and may assist in warranty evaluation. Retain this page for your records.

**UNIT AND PURCHASE INFORMATION**

Model Number: \_\_\_\_\_

Serial Number: \_\_\_\_\_

Date of Purchase: \_\_\_\_\_

Purchased From (Dealer / Supplier): \_\_\_\_\_

Dealer Contact (if available): \_\_\_\_\_

**INSTALLATION DETAILS**

Installation Date: \_\_\_\_\_

Installation Location (Site / Address): \_\_\_\_\_

Installed By (Company / Technician Name): \_\_\_\_\_

Installer Contact (if available): \_\_\_\_\_

<b>INSTALLATION VERIFICATION</b>	<b>STARTUP AND OPERATION CHECK</b>
Unit Level and Stable: <input type="checkbox"/> Yes <input type="checkbox"/> No	Bowls, Gaskets, Dispensing Valves, Stir Rods, and Stirring Paddles Installed Correctly: <input type="checkbox"/> Yes <input type="checkbox"/> No
Required Airflow Clearances Maintained: <input type="checkbox"/> Yes <input type="checkbox"/> No	No Leaks Present After Filling / Startup: <input type="checkbox"/> Yes <input type="checkbox"/> No
Installed Away from Major Heat Sources and Direct Sunlight: <input type="checkbox"/> Yes <input type="checkbox"/> No <input type="checkbox"/> N/A	Stirring System Operates Correctly: <input type="checkbox"/> Yes <input type="checkbox"/> No
Ambient Air Temperature at Installation: _____	Refrigeration System Operates Correctly: <input type="checkbox"/> Yes <input type="checkbox"/> No
Dedicated Grounded Outlet Verified: <input type="checkbox"/> Yes <input type="checkbox"/> No	Abnormal Noise, Vibration, Odour, or Fault Conditions Present: <input type="checkbox"/> Yes <input type="checkbox"/> No - if yes, discontinue use and investigate before operation
Electrical Supply Matches Rating Label: <input type="checkbox"/> Yes <input type="checkbox"/> No	
<b>CLEANING AND HANDOVER</b>	
Initial Cleaning and Sanitizing Completed: <input type="checkbox"/> Yes <input type="checkbox"/> No	Operator Instructed to Confirm Stir Rod and Stirring Paddle Are Installed Before Filling Bowls: <input type="checkbox"/> Yes <input type="checkbox"/> No
Operator Received Basic Operating Instructions: <input type="checkbox"/> Yes <input type="checkbox"/> No	User Manual Provided to Operator: <input type="checkbox"/> Yes <input type="checkbox"/> No
Operator Instructed to Leave Refrigeration and Stirring ON During Normal Use: <input type="checkbox"/> Yes <input type="checkbox"/> No	Final Operational Check Completed: <input type="checkbox"/> Yes <input type="checkbox"/> No
	Warranty Registration Completed: <input type="checkbox"/> Yes <input type="checkbox"/> No

**NOTES / OBSERVATIONS**

\_\_\_\_\_  
 \_\_\_\_\_  
 \_\_\_\_\_

**INSTALLER CONFIRMATION**

Installer Name: \_\_\_\_\_

Signature: \_\_\_\_\_

Date: \_\_\_\_\_

**6 Loring Drive, Bolton, Ontario L7E 1H5 | 1-877-667-4682 (1-877-NORIOTA)**  
**support@noriota.ca**  
**www.noriota.ca**

**© 2026 NORIOTA. All rights reserved.**