

NORIOTA

Intertek
ANSI/UL 471
CAN/CSA-C22.2
No. 120

Intertek
ANSI/NSF 18



NBD3

NBD3 REFRIGERATED BEVERAGE DISPENSER, THREE BOWL

FEATURES & BENEFITS

- **Three 12 L bowls provide a combined 36 L (9.5 gal) beverage capacity**, supporting approximately 101 servings per fill based on a 355 mL (12 oz) serving size.
- **Three beverage offerings from one compact countertop footprint** help maximize menu flexibility without consuming excessive counter space.
- **Durable clear polycarbonate bowls** provide excellent impact resistance while showcasing colourful beverages for increased product visibility.
- **Continuous rotating stirring paddles** help maintain beverage consistency and presentation during service.
- **Commercial refrigeration system** helps maintain cold beverage temperatures during continuous service periods.
- **Removable bowls** simplify daily cleaning and routine maintenance.
- **Removable dispensing components** allow thorough cleaning of beverage-contact surfaces and simplify sanitation procedures.
- **Supports a wide variety of beverage offerings** including juice, iced tea, lemonade, fruit beverages, flavoured water, and other cold non-carbonated drinks.
- **Customer-facing beverage presentation** helps showcase colourful beverages and attract attention in self-serve and assisted-service environments.
- **Compact countertop design** fits cafeterias, convenience stores, restaurants, concession stands, recreation facilities, and similar commercial environments.
- **Simple control layout** supports straightforward day-to-day operation and staff training.

NORIOTA

www.noriota.ca | support@noriota.ca | 1-877-NORIOTA

NORIOTA

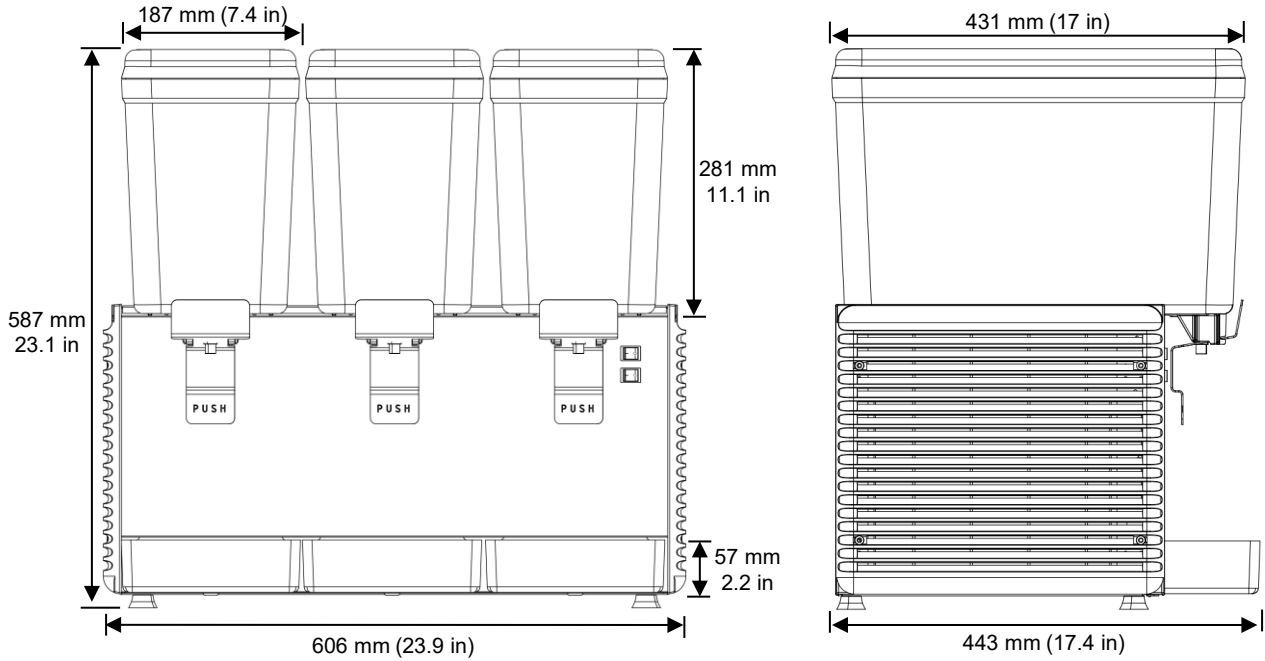

NBD3 REFRIGERATED BEVERAGE DISPENSER, THREE BOWL

Model No.	NBD3
Number of Bowls	3
Number of Dispensing Valves	3
Bowl Material	Polycarbonate
Exterior Construction	Stainless steel front panel, plastic side panels, plastic drip tray
Bowl Capacity	12 L (3.2 gal) each
Total Beverage Capacity	36 L (9.5 gal)
Approximate Servings Per Fill	34 servings at 355 mL (12 oz) per bowl 101 servings at 355 mL (12 oz) total
Recommended Beverage Types	Pre-mixed, cold non-carbonated beverages
Refrigerant	R134a
Refrigerant Charge	325 g (11.47 oz)
Electrical	120 V / 60 Hz / 1 Ph
Rated Current	6.0 A
Power Consumption	510 W
Compressor Power	1/3 HP
Plug Type	NEMA 5-15P
Recommended Ambient Air Temperature Operating Range	15 °C to 25 °C (59 °F to 77 °F)
Installation Type	Countertop
Minimum Installation Clearance	20 cm (8 in) at sides and rear
Unit Dimensions	60.6 x 44.3 x 58.7 cm (23.9 x 17.4 x 23.1 in)
Unit Weight	36.9 kg (81.4 lb)
Shipping Dimensions	63.0 x 48.2 x 68.0 cm (24.8 x 19.0 x 26.8 in)
Shipping Weight	39.8 kg (87.8 lb)
Warranty	2 years parts & labour, 5 years compressor parts only

NORIOTA

www.noriota.ca | support@noriota.ca | 1-877-NORIOTA

June 2026

All specifications subject to change without notice.