

# NORIOTA



Intertek  
ANSI/UL 471  
CAN/CSA-C22.2  
No. 120



Intertek  
ANSI/NSF 18



**NBD3SS**

**NBD3SS REFRIGERATED BEVERAGE DISPENSER, THREE BOWL**

## FEATURES & BENEFITS

- **Three 12 L bowls provide a combined 36 L (9.5 gal) beverage capacity**, supporting approximately 101 servings per fill based on a 355 mL (12 oz) serving size.
- **Three beverage offerings from one compact countertop footprint** help maximize menu flexibility without consuming excessive counter space.
- **Stainless steel exterior panels** provide a premium appearance for customer-facing beverage stations and front-of-house service areas.
- **Durable clear polycarbonate bowls** provide excellent impact resistance while showcasing colourful beverages for increased product visibility.
- **Continuous rotating stirring paddles** help maintain beverage consistency and presentation during service.
- **Commercial refrigeration system** helps maintain cold beverage temperatures during continuous service periods.
- **Removable bowls** simplify daily cleaning and routine maintenance.
- **Removable dispensing components** allow thorough cleaning of beverage-contact surfaces and simplify sanitation procedures.
- **Supports a wide variety of beverage offerings** including juice, iced tea, lemonade, fruit beverages, flavoured water, and other cold non-carbonated drinks.
- **Customer-facing beverage presentation** helps showcase colourful beverages and attract attention in self-serve and assisted-service environments.
- **Simple control layout** supports straightforward day-to-day operation and staff training.

NORIOTA

[www.noriota.ca](http://www.noriota.ca) | [support@noriota.ca](mailto:support@noriota.ca) | 1-877-NORIOTA

# NORIOTA

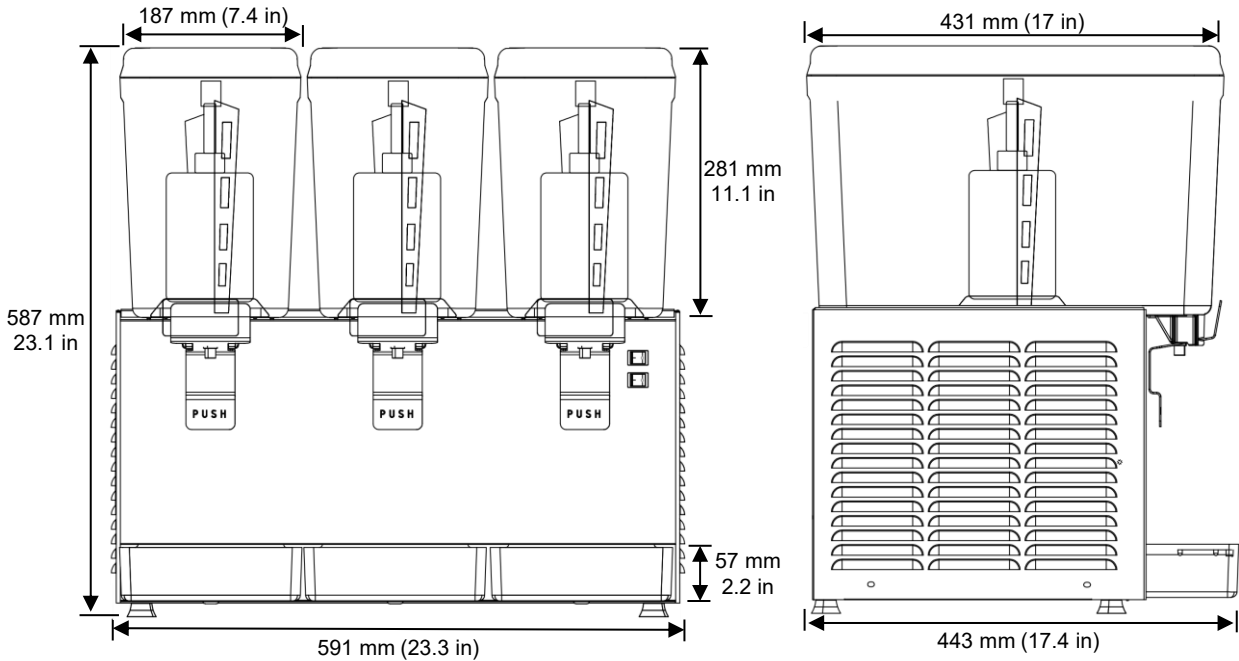

**NBD3SS REFRIGERATED BEVERAGE DISPENSER, THREE BOWL**

<b>Model No.</b>	<b>NBD3SS</b>
<b>Number of Bowls</b>	3
<b>Number of Dispensing Valves</b>	3
<b>Bowl Material</b>	Polycarbonate
<b>Exterior Construction</b>	Stainless steel front and side panels, plastic drip tray, stainless steel drip tray grate
<b>Bowl Capacity</b>	12 L (3.2 gal) each
<b>Total Beverage Capacity</b>	36 L (9.5 gal)
<b>Approximate Servings Per Fill</b>	34 servings at 355 mL (12 oz) per bowl 101 servings at 355 mL (12 oz) total
<b>Recommended Beverage Types</b>	Pre-mixed, cold non-carbonated beverages
<b>Refrigerant</b>	R134a
<b>Refrigerant Charge</b>	325 g (11.47 oz)
<b>Electrical</b>	120 V / 60 Hz / 1 Ph
<b>Rated Current</b>	6.0 A
<b>Power Consumption</b>	510 W
<b>Compressor Power</b>	1/3 HP
<b>Plug Type</b>	NEMA 5-15P
<b>Recommended Ambient Air Temperature Operating Range</b>	15 °C to 25 °C (59 °F to 77 °F)
<b>Installation Type</b>	Countertop
<b>Minimum Installation Clearance</b>	20 cm (8 in) at sides and rear
<b>Unit Dimensions</b>	59.1 x 44.3 x 58.7 cm (23.3 x 17.4 x 23.1 in)
<b>Unit Weight</b>	39.1 kg (86.4 lb)
<b>Shipping Dimensions</b>	63.0 x 48.2 x 68.0 cm (24.8 x 19.0 x 26.8 in)
<b>Shipping Weight</b>	42.1 kg (92.8 lb)
<b>Warranty</b>	2 years parts & labour, 5 years compressor parts only

NORIOTA

www.noriota.ca | support@noriota.ca | 1-877-NORIOTA

June 2026

All specifications subject to change without notice.