

NORIOTA



NHP36



NHP36 GAS HOT PLATE, 6 BURNERS, 36 IN

FEATURES AND BENEFITS

Fully welded stainless steel front with bullnose: Durable commercial construction built for daily use in demanding kitchen environments.

Designed for high-volume commercial use: Supports continuous multi-pot cooking in busy kitchen environments.

Cast iron burners, 30,000 BTU/hr each: Delivers strong heat for high volume boiling, sautéing, and other high-demand commercial cooking tasks.

Independent manual controls with standing pilots: Gives operators direct burner control with reliable ignition and flexible heat adjustment across each cooking zone.

Removable cast iron top grates: Supports multiple pots securely and lifts off easily for cleaning and maintenance.

30.5 x 30.5 cm (12 x 12 in) grate size per section: Provides a practical cooking surface for stock pots, sauce pots, and sauté pans in busy commercial kitchens.

Full-width burner layout: Supports multi-pot cooking across separate burner positions during busy service.

Removable stainless steel crumb tray: Helps simplify routine cleanup and keeps the cooking area easier to maintain.

10.2 - 12.7 cm (4 - 5 in) adjustable stainless steel legs: Supports stable installation and easier leveling on uneven commercial surfaces.

Ships configured for Natural Gas, field convertible to Liquid Propane (LPG): Provides installation flexibility using included conversion components.

NORIOTA

www.noriota.ca | support@noriota.ca | 1-877-NORIOTA

N O R I O T A

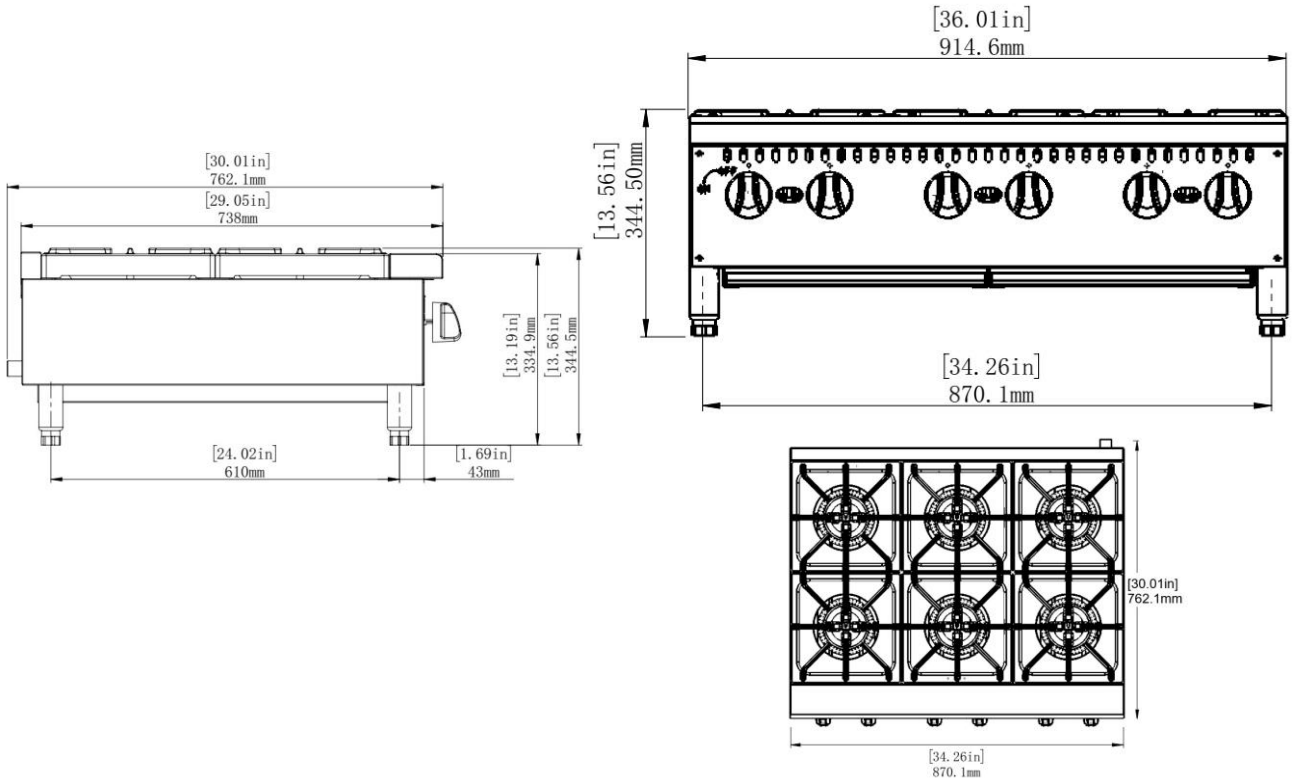

NHP36 GAS HOT PLATE, 6 BURNERS, 36 IN

Technical Data

Gas Type	Ships configured for Natural Gas, field convertible to Liquid Propane (LPG) using included conversion components
Gas Connection	3/4 in NPT
Minimum Supply Pressure	Natural Gas: 4 in. W.C., Liquid Propane: 10 in. W.C.
Burner Type	Cast iron
Burner Input	30,000 BTU/hr per burner
Number of Burners	6
Total Heat Input	180,000 BTU/hr total
Ignition Type	Standing pilot
Burner Control	Independent manual control valve for each burner
Cooking Grates	Cast iron, removable
Grate Size (W x D)	30.5 x 30.5 cm (12 x 12 in) per grate
Crumb Tray	Removable stainless steel
Legs	Adjustable 10.2 - 12.7 cm (4 - 5 in) stainless steel
Flue / Ventilation Requirements	For commercial indoor use under an approved ventilation hood in accordance with local codes
Unit Dimensions (W x D x H)	91.5 x 76.2 x 34.5 cm (36 x 30 x 13.6 in)
Unit Weight	77 kg (169.8 lb)
Shipping Dimensions (W x D x H)	74 x 87.5 x 41.5 cm (29.1 x 34.5 x 16.3 in)
Shipping Weight	100.5 kg (221.6 lb)
Warranty	2 years parts & labour
Includes	Gas regulator, (4) adjustable legs, removable crumb tray, gas conversion kit

NORIOTA

www.noriota.ca | support@noriota.ca | 1-877-NORIOTA

March 2026