

N O R I O T A



NR60

FEATURES AND BENEFITS

Stainless steel front, back riser, shelf, and support legs: Durable commercial construction with a clean professional appearance.

Ships configured for natural gas, field convertible to LPG: Provides installation flexibility using included conversion components.

10 open burners, 30,000 BTU/hr each: High total heat output supports heavy-duty, high-volume cooking across multiple stations.

Removable 30.5 x 30.5 cm (12 x 12 in) cast iron grates: Heavy-duty grate design supports cookware securely and simplifies cleaning.

Independent manual controls with standing pilots: Provides straightforward operation and individual flame control at each burner.

Dual 30,000 BTU/hr ovens: Expands cooking capacity with two independent ovens for baking, roasting, and finishing tasks.

Adjustable oven thermostat, 121 °C to 288 °C (250 °F to 550 °F): Provides flexible temperature control across a wide range of cooking applications.

Full-size sheet pan capacity ovens: Each oven accommodates standard full-size sheet pans for greater flexibility in commercial kitchen workflows.

Spring-assisted oven door with cool-touch handle: Supports easier daily use and safer handling during busy service.

Steel oven sides with porcelain bottoms: Built for commercial use with smooth oven floors that are easier to clean.

Removable crumb trays and two oven racks per oven included: Helps simplify cleanup and supports flexible oven configuration.

NR60 GAS RANGE WITH OVEN, 10 BURNERS, 60 IN

NORIOTA

NR60 GAS RANGE WITH OVEN, 10 BURNERS, 60 IN

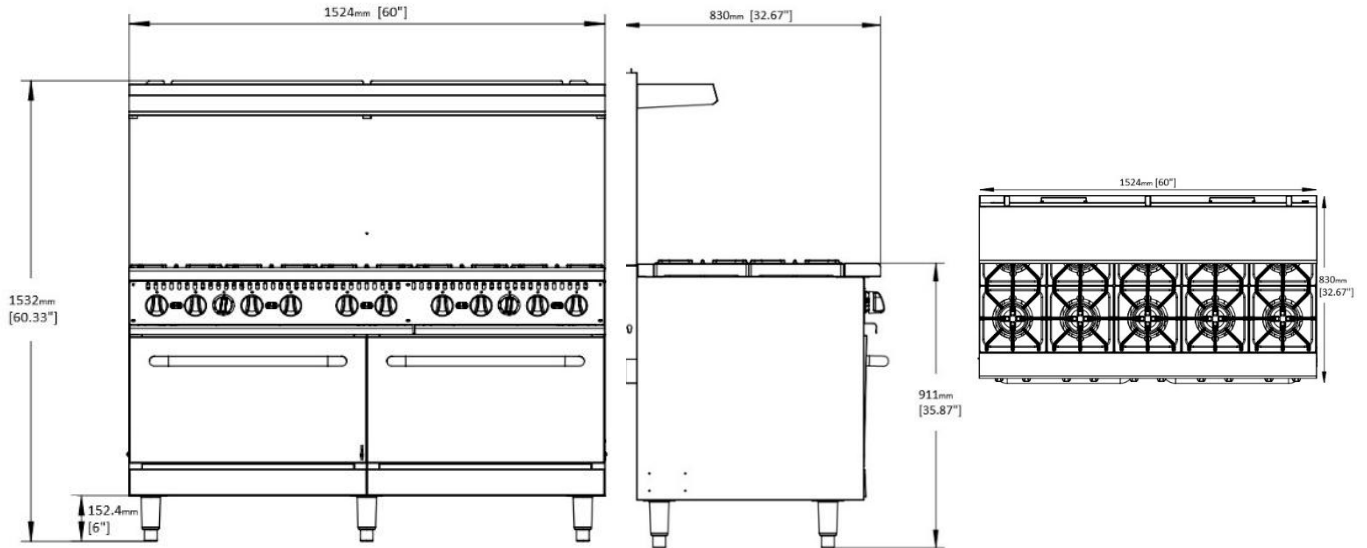

Technical Data

Gas Type	Ships configured for Natural Gas, field convertible to Liquid Propane (LPG) using included conversion components
Gas Connection	3/4 in NPT
Minimum Supply Pressure	Natural Gas: 5 in. W.C., Liquid Propane: 10 in. W.C.
Top Configuration	10 open burners with removable cast iron grates
Burner Input	30,000 BTU/hr per burner
Number of Burners	10
Oven Input	30,000 BTU/hr
Number of Ovens	2
Total Heat Input	360,000 BTU/hr total (300,000 burners + 60,000 ovens)
Ignition Type	Standing pilot
Burner Control	Independent manual control valve for each burner
Burner Grates	30.5 x 30.5 cm (12 in x 12 in), removable cast iron
Front Ledge	12.7 cm (5 in) deep, stainless steel
Oven Dimensions (W x D x H)	66 x 66 x 35.6 cm (26 x 26 x 14 in) per oven
Oven Capacity	Fits full-size sheet pans (each oven)
Oven Thermostat Range	121°C – 288 °C (250 °F – 550 °F)
Oven Interior	Steel sides with porcelain bottom
Oven Racks	2 racks per oven, multiple position
Oven Door	Stainless steel, spring-assisted closing with cool-touch handle
Back Riser	62.9 cm (24.75 in) high
Legs / Castors	15.2 cm (6 in) adjustable stainless steel legs, castors optional
Flue / Exhaust Requirements	Rear flue, requires installation under a commercial ventilation hood in accordance with local codes
Unit Dimensions (W x D x H)	152.4 x 83 x 153.2 cm (60 x 32.67 x 60.33 in)
Working Height	91.1 cm (35.9 in)
Unit Weight	244 kg (538 lb)
Shipping Dimensions (W x D x H)	163 x 101 x 89 cm (64.2 x 39.8 x 35.1 in)
Shipping Weight	285 kg (628 lb)
Warranty	2 years parts & labour
Includes	(1) stainless back riser, (4) oven racks, (2) crumb trays, (6) adjustable legs, (1) gas conversion kit

NORIOTA

www.noriota.ca | support@noriota.ca | 1-877-NORIOTA

March 2026

All specifications subject to change without notice.