

N O R I O T A

GAS STOCK POT RANGES – HEAVY DUTY



NSPR1



NSPR2

FEATURES & BENEFITS

- **Robust Stainless Steel Build:** Stainless steel construction that is fully welded for strength and durability
- **High-Output Burners:** 90,000 BTU per burner in a double flame 3-ring configuration
- **Heavy Duty Cast Iron Grate:** 4.8 cm (1.875 in) thick cast iron grates can be easily lifted off for cleaning or maintenance
- **Easy Ignition:** Each burner includes an individual standing pilot and control knob for quick and reliable ignition
- **Easy Cleaning:** A removable drip tray simplifies maintenance and keeps the cooking area clean
- **Adjustable Legs:** 15.2 cm (6 in) heavy duty steel legs with adjustable feet, offers stability and adaptability, ensuring a secure and level setup on any surface
- **Versatile Gas Compatibility:** Ships ready for natural gas use but can be easily converted to liquid propane in the field with included parts

GAS

NSPR*: Natural Gas Field convertible to Liquid Propane with included components $\frac{3}{4}$ " gas connection

WARRANTY

2-year parts & labour

NORIOTA Ltd

www.noriota.ca | support@noriota.ca | 1-877-NORIOTA

Minimum supply pressure:
4" W.C. for Natural Gas
10" W.C. for Liquid Propane

NORIOTA

GAS STOCK POT RANGES – HEAVY DUTY

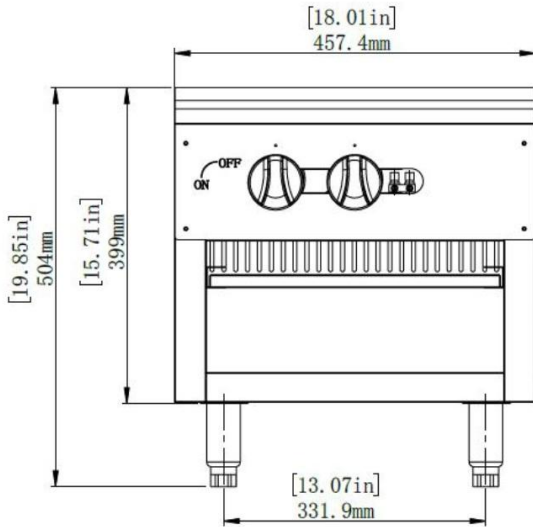

NSPR1

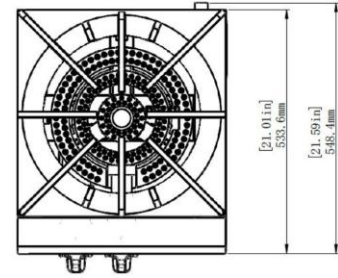

NSPR2

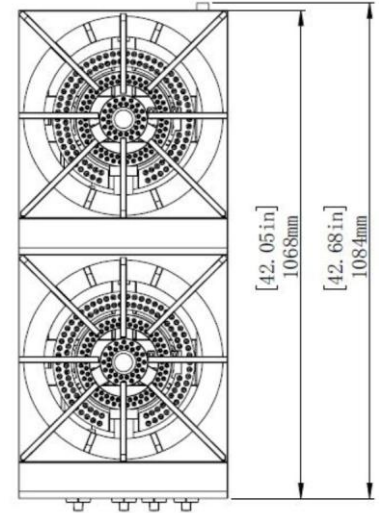

	NSPR1	NSPR2
BTU	90,000	180,000
# of Burners	1	2
Grate Size (W x D)	45.7 x 53.4 cm 18 x 21 in	
Cooking Surface	Heavy Duty 4.8 cm (1.875 in) Thick Cast Iron Grates and Burners, Removable	
Temperature Control	Manual, Dual Control Knobs for Each Burner for More Precise Gas Flow	
Ignition	Standing Pilot (2 Per Burner)	
Removable Crumb Tray	Yes, Stainless Steel	
Legs	Adjustable 15.2 cm (6 in) Stainless Steel	
Unit Dimensions (W x D x H)	45.7 x 54.8 x 50.4 cm 18 x 21.6 x 19.9 in	45.7 x 108.4 x 50.4 cm 18 x 42.7 x 19.9 in
Unit Weight	43 kg (94.6 lb)	83.5 kg (183.7 lb)
Shipping Dimensions (W x D x H)	50 x 65 x 42.4 cm 19.7 x 25.6 x 16.7 in	50 x 118.6 x 42.4 cm 19.7 x 46.7 x 16.7 in
Shipping Weight	53 kg (116.6 lb)	102.5 kg (225.5 lb)
Includes		
(4) adjustable legs, (1) gas conversion kit		